

ELECTRICAL SERVICE REQUIREMENTS

METERING EQUIPMENT, MTR

TABLE OF CONTENTS

| TITLE | SECTION NO. |
|---|-------------|
| General..... | MTR-100 |
| Meter Sockets | MTR-101 |
| Meter Main Switch | MTR-102 |
| Main Service Disconnect - Multiple Metering | MTR-103 |
| Metering Equipment Installations..... | MTR-104 |
| Meter Locations | MTR-105 |
| Residential Occupancies | MTR-106 |
| Commercial and Industrial Occupancies | MTR-107 |
| Factory Wired Safety Socket Boxes | MTR-108 |
| Grounding and Bonding..... | MTR-109 |
| Electric Meter Room..... | MTR-110 |

LIST OF DRAWINGS

| TITLE | DRAWING NO. |
|--|-------------|
| Typical Plaque/Directory Specifications | MTR-DWG-001 |
| Meter Socket - Terminal Arrangements | MTR-DWG-002 |
| Meter Switches and Main Disconnects..... | MTR-DWG-003 |
| Separation of Meter Assemblies for Electric and Gas Services | MTR-DWG-004 |
| Work space and Meter Clearances 0-600 | MTR-DWG-005 |
| Meter Room Clearances..... | MTR-DWG-006 |
| Working Space and Clearance Requirements, 0-300 Volts..... | MTR-DWG-007 |
| Protective Barrier for Service Equipment Installation Requirements ... | MTR-DWG-008 |
| Typical Distributed Generation | MTR-DWG-009 |

Single and Three-Phase Meters and Metering Equipment

All meter installations shall comply with GWP Electrical Service Requirements, along with City of Glendale, Public Works Division, Building and Safety Section, and all applicable governing laws and ordinances.

If any question arises concerning these requirements, contact GWP, Customer Service Engineering at (818) 548-3921, or at 141 N. Glendale Ave., 4th Level.

Whenever any electrical service is installed, provisions shall be made for the installation of metering equipment complying with these requirements. Existing service equipment which, in the opinion of GWP, and City of Glendale Public Works Division, Building and Safety Section is satisfactory and adequate for the application may be reused.

Meters will be installed by GWP when the necessary metering facilities are provided and the installation has been approved for service by City of Glendale, Public Works Division, Building and Safety Section and GWP Construction Inspector. Meters will not be installed on any installation which does not meet the requirements of GWP.

Unauthorized persons are prohibited from altering or changing, in any way, a meter or its connections. All enclosures and raceways on the line side (unmetered) or housing metering equipment shall be sealable. Meter seals shall not be broken by anyone except by an authorized GWP employee. **See GEN-100, Page 6 of 10, Notice of Meter Tampering and Un-Metered Service Requirements.**

Service equipment exposed to the weather shall be NEMA - 3R, rain tight.

For the purpose of these specific requirements, a customer installing his or her own wiring will be considered the electrical contractor.

Refer to **Section MTR-109** for bonding and grounding requirements.

Photovoltaic Systems

These pages were superseded by the new section of the GWP Electrical Service Requirements named Distributed Generation Resources.

Every new service installation shall be equipped with an approved meter socket and sealing ring together with its supporting raceway or box where these are required. These items shall be furnished and installed by the electrical contractor.

All meter fittings shall be mounted on a substantial support in a true vertical position.

When meters are in place, meter socket terminals shall not be accessible and meter mounting panels shall be non-removable.

Where a self-contained “A” base meter is in place, and the meter is relocated on the same building or an increase in load requires the installation of larger service conductors or a larger raceway, a new meter panel or switchboard shall be installed.

Meter sockets equipped with circuit closing devices shall not be installed. Ringless type socket enclosures shall not be installed. Any such equipment installed, shall be replaced at the customer’s expense.

Refer to **Drawing MTR-DWG-002** for meter socket terminal arrangements.

All new sockets for self-contained metering applications shall be U.L. Listed. Residential meter panels may have a maximum ampere rating of 125, 225 or 400 amperes. **See Underground Chapter (UG), Section UG-104 “Terminating Enclosures”.**

When a service installation does not serve an entire building, the installation shall be permanently marked with a plaque by the contractor to indicate the portion of the premises served. The plaque or directory required shall be metal or plastic, with engraved or machine printed letters, or Electro-Photo plating, in contrasting color to the plaque. The plaque shall include a plat map of the entire building, and shall be attached to the service disconnect with pop-rivets, screws, or epoxy. **See Drawing MTR-DWG-001.**

Refer to EUSERC DRAWING #306, and EUSERC DRAWING #332 for details of meter socket panel installations in switchboard service sections.

For each and every meter, the contractor shall furnish and install a meter main disconnect, or other approved disconnecting means with over-current protection. This is referred to as the "Meter Main Disconnect". It shall be installed at the same location and directly adjacent to the metering and service equipment. The meter main disconnect shall control all of, and only, the energy registered by that meter. Where permitted by local code or ordinances, the meter main disconnect may consist of a group of disconnects, switches or breakers, per NEC 230-71. A separate meter main disconnect will be required for each separate service, or any group where the loads are totalized by a single meter.

Number of Disconnects

Every meter or service shall be furnished with a meter main disconnect as described in above paragraph. GWP allows up to a maximum of six switches or disconnects for a multi meter commercial or industrial service, only if aggregate of all service mains does not exceed the electrical service size. A residential service may have a maximum of two switches or disconnects for each single family service.

Sequence

Every meter main disconnect installed on an individual service less than 600 volts shall be on the load side of the meter or metering equipment. For services over 600 volts, **consult GWP.**

Multiple Metering

A main service disconnect shall be installed on the line side of a group of more than six meter sockets, safety socket boxes or switchboards.

A main service disconnect shall be installed on the line side of groups of two to six meter sockets, safety socket boxes or switchboards where groups of switches, circuit breakers, or disconnects that constitute the meter main switch, and the total number of switches or disconnects exceeds six.

The main service disconnect may be a fused switch, or a circuit breaker. Where fuses are installed, GWP is not responsible for their replacement. Main service disconnect enclosures containing un-metered conductors shall be sealable.

If a meter has between two to six meter main switches, a permanent visible sign shall be affixed to the panel stating, "Six disconnect rule applies, there are more than one service mains." Each service main shall be individually labeled with a number. For example; Service Main 1, Service Main 2, Service Main 3, etc.

Each service main shall be equipped with pad-lock provisions.

The center line of any meter socket shall not be more than 6 feet 3 inches or less than 4 feet above the standing and working surface. Exception: The minimum height of a meter may be reduced to 3 feet when the meter has been enclosed, i.e.: in a meter room, multiple meter closet or commercial meter pedestal.

The minimum meter clearance and work space permitted between other meters and sidewalls, ceilings, tops, bottoms and other obstructions shall be as **illustrated in drawings MTR-DWG-004 and MTR-DWG-005.**

The minimum inside dimension depth of any closet or enclosure for single phase residential meters shall be 7 inches from the face of the meter panel. The minimum inside dimension depth of any enclosure for all other meters shall be 11 inches from the face of the meter panel. The maximum inside dimension depth of recess for all meters shall be 12 inches from the face of the meter panel. **See drawing MTR-DWG-005.**

A level standing and working surface, entirely on the property served, clear and unobstructed, at least equal to the width and height of the meter space (but not less than 36 inches wide and 6 feet 6 inches high) and extending at least 36 inches from the face of the meter panel surface shall be provided. A level standing and working surface shall also be provided when meters are enclosed in a cabinet or enclosure. The clear space shall extend at least 36 inches from the outer face of the cabinet or enclosure. **See drawing MTR-DWG-005.**

All metering facilities shall be located such that GWP has 24-hour access, and preferably on the exterior building wall.

GWP shall be contacted to approve the location prior to the installation of meter/service equipment. Any service equipment which has been installed without prior GWP approval may require modification or relocation at the customer's/contractor's expense.

Where it is determined that all current and future metering facilities are to be installed on an exterior wall, and adequate wall space in an approved location is not available, the builder or architect shall provide a meter closet or illuminated meter room with approved exterior access (**roll up doors are not acceptable**) in which all of the required meter and service facilities may be properly installed. When meters or metering equipment are installed in a lockable enclosure, the door is to be equipped with a heavy duty lock, knob type and finish to be customer's choice. Coordinate with GWP construction inspector for the installation requirements for a GWP lockbox.

For all single and three-phase self-contained meter installations with individual meter switches rated 200 amperes and below, serving any single or multiple occupancy building (including condominiums in common tenancy and townhouses developed with common areas), the meter and service equipment shall be grouped in one readily accessible central location. When existing meter and service equipment have been established for a building, additional meter and service equipment shall be located with the existing equipment. Consult GWP for assistance in determining acceptable meter and service locations.

No meter or service equipment shall be installed within any individual residential occupancy, in any type of single or multiple occupancy building; within any individual commercial occupancy which it does not serve; or in any location prohibited as **identified in Table 2, section MTR-105, pages 3 & 4**. GWP shall be contacted prior to the installation of any meter/service equipment.

Table 1, section MTR-105, page 2 identifies the type of occupancy for meter installations.

Table 1 Meter Location per Type of Occupancy

| Type of Building | |
|-------------------------|--|
| 1. | Dwellings or Apartments - Meter and service equipment shall be installed on an exterior wall or exterior meter closet and so located that the meter and service equipment will be accessible without entering the building. Meter locations shall be selected so that future building or other structural changes (i.e., fences, patio enclosures, etc.) will not make the metering facilities inaccessible. |
| 2. | Single Story Buildings - Meter and service equipment may be installed inside a building when located in an illuminated meter room directly accessible from the outside and readily accessible 24 hours a day. |
| 3. | Multi-Story Buildings (other than dwellings or apartments) - Meter and service equipment shall be installed as required for single story buildings. |

Meter Access

Meters and/or metering equipment shall be readily accessible 24 hours a day.

Access to metering equipment shall be through a door (roll up doors are not acceptable) on the building exterior which opens directly into the meter closet or meter room.

When meter access problems result due to metering equipment being improperly located and GWP has not approved the location, the customer shall make all the required modifications, at the customer's expense.

Table 2 Prohibited Meter Locations (sheet 1 of 2)

| No metering or service equipment shall be located in any of the following places: | |
|--|--|
| 1. | Any place where moisture, fumes or dust may interfere with their operation or cause damage. The metering equipment may be enclosed to prevent any such result. Contact GWP for specific details. |
| 2. | Any elevator shaft or hatchway. |
| 3. | Any room containing elevator equipment. |
| 4. | Behind any switchboard having bare or exposed live parts unless such meter is located at least five feet from such parts and is effectively barred therefrom. |
| 5. | Any projection room. |
| 6. | Any hazardous location or locations where GWP employees would need to pass through a hazardous area to gain access to metering or service equipment. |
| 7. | Attic or any place not in general use. |
| 8. | Show window or behind a sales counter. |
| 9. | Restroom, shower, bath or toilet room. |
| 10. | Directly over any door, window, stairway, ramp, steps or stairs. |
| 11. | Directly over or 36" horizontally from a gas meter or pipe or 18" horizontally from plumbing fixture which extends more than 6" out from the wall. See Drawing MTR-DWG-004. |
| 12. | Mechanical or other type of room or structure that contains motors, valves, or any piping which is under pressure. |
| 13. | Inside any building, unless located within an acceptable meter room which has 24-hour access. |
| 14. | Meters shall not be located so as to require reading or servicing from within the fenced portion of a freeway. |

Table 2 (continued) Prohibited Meter Locations (sheet 2 of 2)

| No metering or service equipment shall be located in any of the following places: | |
|--|--|
| 15. | Garage, carport, breezeway, or patio which may be enclosed. |
| 16. | Balcony, mezzanine floor, or other elevated location. In any underground vault or other depressed location unless approved by GWP. These locations must be accessible by a stairway of normal tread and rise. A stairway of normal rise (4" to 7") and run (11" min.) and conforming to building code requirements is acceptable. Entrance to the location shall be through a vertical doorway not less than 36" wide and 78" high or through an access way approved by GWP. |
| 17. | On or recessed in any wall in a school building accessible to student traffic. Meters are not permitted in school hallways. |
| 18. | On or recessed in any wall or structure with less than 3' of clear level work space in front of the metering equipment or its enclosure(s). This space shall not be impeded by property lines, public thoroughfares, alleys, driveways and walks. |
| 19. | Any location not readily accessible 24-hours a day for meter reading, maintenance or replacement of the metering/service facilities. |
| 20. | Any area protected by alarm systems, security gates/doors, guard dogs, etc., unless approved by GWP. |
| 21. | On mobile homes or trailers. |
| 22. | Meters are not to be placed on GWP poles, either jointly or solely owned, except for city agencies with GWP approval. |

Individually Metered Single-Phase, 3-Wire 120/240 Volt Services

Refer to drawing **MTR-DWG-002** for meter socket terminal requirements.

Multi-family occupancies which are not individually metered shall be served in accordance with the requirements for commercial and industrial occupancies.

When a meter switch does not exceed 125 amperes, a 125 maximum ampere rated, four terminal socket shall be installed.

When a meter switch exceeds 125 amperes, but does not exceed 225 amperes, a 225 maximum ampere rated, four terminal socket shall be installed.

When a meter switch exceeds 225 amperes, but does not exceed 400 amperes (Class 320), a self-contained panel shall be installed, see **EUSERC DRAWING #302A**. If the meter switch exceeds 400 amperes (Class 320), a switchboard shall be installed, see **SWITCHBOARD (SWBD) chapter**.

Single-Phase, 3-Wire 120/240 Volt Services

Refer to drawing **MTR-DWG-002** for meter socket terminal requirements.

When a meter switch does not exceed 125 amperes, a factory-wired safety socket box with a 125 ampere continuous duty rated, four terminal socket shall be installed.

When a meter switch exceeds 125 amperes, but does not exceed 200 amperes, a factory-wired safety socket box with a 200 ampere continuous duty rated, four terminal socket shall be installed.

When a meter switch exceeds 200 amperes, a switchboard shall be installed, **see SWITCHBOARD (SWBD) chapter.**

Three-Phase, 4-Wire 120/208 Volt and Three-Phase, 3-Wire 240 Volt Services

Refer to drawing MTR-DWG-002 for meter socket terminal requirements.

Where a meter switch does not exceed 125 amperes, a factory-wired safety socket box with a 125 ampere continuous duty rated socket shall be installed.

Where a meter switch exceeds 125 amperes, but does not exceed 200 amperes, a factory-wired safety socket box with a 200 ampere continuous duty rated socket shall be installed.

When a meter switch exceeds 200 amperes, a switchboard shall be installed, **see SWITCHBOARD (SWBD) chapter.**

Sockets for 120/208 volt three-phase, four-wire services shall be self-contained seven jaw or transformer rated fifteen jaw, regardless of whether or not the load served utilizes a neutral.

Sockets for 240 volt three-phase power services shall be self-contained five jaw or transformer rated eight or fifteen jaw. Consult GWP for details.

Three-Phase, 4-Wire, 277/480 Volt and Three-Phase, 3-Wire 480 Volt Services

All 100, 200, and 400 ampere services require a switchboard. See **SWITCHBOARD (SWBD) chapter**. Sockets for 277/480 volt services shall be transformer rated fifteen jaw, and sockets for 480 volt services, shall be transformer rated eight or fifteen jaw. Consult GWP for details.

Meter Sockets - Self-Contained, Non-Residential

Self-contained, meter sockets for non-residential services are only permitted for services rated at 100A and 200A and voltages up to 240 Volt, single-phase and three-phase. A safety socket box with factory installed test-bypass blocks, **as detailed in section MTR-108**, will be required for the following types of installations:

- Commercial and industrial - including all public buildings.
- All three-phase installations (including customer owned permanent and temporary service meter poles).
- All service pedestals
- All Live Work Units.

Exception

A safety socket panel will not be required for single-phase services of a strictly temporary nature.

GWP shall be contacted to approve service equipment. Any service equipment without prior GWP approval may require modification or relocation at the customer's/contractor's expense.

FACTORY WIRED SAFETY SOCKET BOXES

MTR-108

All factory wired safety socket boxes shall have factory installed test by-pass blocks which are factory bussed or wired to the meter socket on both line and load sides. Factory wired safety socket boxes shall be listed and labeled with a 100/200 ampere continuous duty rating.

Test by-pass block terminals shall be suitable for copper/aluminum conductors. Factory wired safety socket boxes with 100 ampere continuous duty rated sockets shall be served with a maximum of 1/0 AWG conductors. Factory wired safety socket boxes with 200 ampere continuous duty rated sockets shall be served with a maximum of 250 kcmil conductors. **Refer to section MTR-107, and drawings EUSERC DRAWING #304, and EUSERC DRAWING #305 for specific application requirements.**

The wiring sequence of factory installed test by-pass blocks, from left to right, is LINE-LOAD, LINE-LOAD, LINE-LOAD. This wiring sequence shall be permanently labeled in 3/4" block letters below the test by-pass terminals. Line and load conductors shall be connected **ONLY** to test by-pass block terminals designated as LINE and LOAD, respectively.

The contractor shall furnish and install all necessary grounding and bonding on service entrance equipment. **Refer to section MTR-109 for details.**

Not more than one load circuit shall leave any safety socket box. Load wiring may leave from the bottom, bottom side, or bottom rear, but shall not impair access to the test by-pass blocks.

Overhead Service

The contractor shall furnish and install both line and load wiring from the point of service delivery. The neutral or grounding conductor shall be continuous through the safety socket box.

Underground Service

For underground services, a separate terminating pull box will be required. The contractor shall furnish the pull box and install the conductors from the terminating pull box to the safety socket box(es). Consult GWP Customer Service Engineering for details.

The California Public Utilities Commission (CPUC) requires transformer windings to be effectively grounded, and where a secondary system is grounded at any point, the California Public Utilities Commission (CPUC) and the National Electrical Code (NEC) requires the grounded conductor to be run to each service.

The grounding conductor may pass through the metering compartment, but where a bare wire is used, it shall be barriered from the other service entrance conductors.

Grounding for the following service voltages will be:

1. 120/240 volt, single-phase, three-wire service will be supplied from secondary systems with the transformer midpoint grounded.
2. 240 volt, three-phase three-wire delta services will be supplied from secondary systems which have either one-phase grounded or the midpoint of one transformer grounded.
3. 480 volt, three-phase three-wire delta services will be supplied from secondary systems which have either one-phase grounded or the midpoint of one transformer grounded.
4. 277/480 volt, four-wire systems will be wye connected with a grounded neutral supplied with each service whether or not a neutral is required for the load to be served.

With each new service from a grounded secondary system, GWP will install a neutral or grounding conductor. This conductor (or the customer's neutral or grounding conductor connected to it) shall be bonded to the service equipment enclosure under seal and ahead of the meter main switch or main service disconnect. The minimum conductor size shall be in accordance with section 250-23 (b) of the current edition of the National Electrical Code (NEC).

All other service wire installation grounding and bonding is subject to the requirements of applicable Codes. Grounding electrode conductors required by such Codes shall, where practicable, be connected to the neutral or bonding terminals in compartments which will not be under seal.

Electrical Service Grounding and Bonding Diagrams

The Southwestern Section of the International Association of the Electrical Inspectors (IAEI) has issued a bulletin under the title Electrical Service Entrance Grounding and Bonding Diagrams, See attached bulletin (next page). These diagrams are recommended and approved by the Southwestern Section (IAEI). They are, therefore, recognized standards for Arizona, California, Hawaii, Nevada, and New Mexico areas, but are not necessarily the only methods of properly grounding and bonding.

GWP recognizes the value of such standards and has reproduced the diagrams on the following pages. However, with the exception of the bonding requirements detailed previously, these diagrams are not to be considered service requirements of GWP installation details.

Electric Meter Room

A sign stating, “**DO NOT BLOCK OR STORE ANY MATERIAL OR EQUIPMENT IN THE WORKING CLEARANCE AREA**” shall be posted on the electrical room door or in a visible area. Working clearance area shall be painted in a cross hatched pattern. The electrical room light shall be equipped with a manual switch. The meter room must be permanently identified as “Electric Meter Room”, “Meter Room”, or “Electric Room”. Pull sections shall be positioned:

- a) Opposite the access door to allow use of doorway as additional working space for cable - pulling equipment, or
- b) On a wall perpendicular to access door.

Access

Access must be from a door on the exterior building opening directly into the electric room to provide immediate 24 hour a day access. The entrance to the electrical room shall be through a doorway not less than 2'-6" wide and 6'-6" high. The electrical room door must always swing out and utilize “lever operated” hardware.

Foreign Equipment

The following list of equipment is not allowed in an electric meter room:

- Gas equipment, including piping
- Water heaters/boilers, including any piping under pressure
- Storage of any materials, liquids, etc
- DWV piping
- Wet filled batteries and battery charging equipment
- Standby or emergency generators
- Elevator equipment
- Others, as identified by GWP Construction Inspector

Exceptions

Sprinkler supply piping and heads are acceptable when required in an electric meter room by the City of Glendale, Fire Department official or Building and Safety Section official.

Meter Clearances

All meter installations must provide minimum clearances as shown in **MTR-DWG-006**.

Meter Marking

Each meter socket, meter panel or switchboard(s) and related meter/service disconnect shall be clearly and permanently marked by the contractor or customer to indicate the occupancy or load served. Examples of permanent marking are: 1) an identification plate secured by screws, rivets, or equivalent secure adhesive; 2) weatherproof paint applied with stencil or pen; 3) commercially available decals. Identification means a street, apartment, or suite number. Non permanent and permanent felt tip pens are not acceptable.

Vehicle Access

In general, permanent vehicle access to the meter room is required for the installation and maintenance of service cables and metering equipment. Under some conditions, as determined by GWP, the vehicle access requirement may be waived. Consult GWP for details.

Meter Heights for Multi-Residential Meter Panels

When multi-meter service sections are located in a meter room or when fully enclosed in a closet the minimum height of the meter(s) may be 3 feet and the maximum height shall not exceed 6 feet 3 inches. These heights are measured from the standing and working surface to the center of meter.

When multi-meter service sections are wall or surface mounted, but not located in a meter room or enclosure, the minimum height of the meter shall be 4 feet and the maximum height shall not exceed 6 feet 3 inches. These heights are measured from the standing and working surface to the centerline of the meter.

For all others the minimum meter height shall be 4'-0" and the maximum shall be 6'-3".

Working Space - Metering and Service Equipment

Working space is required to permit access to the metering and service equipment and to provide safe working space for GWP personnel. A level and unobstructed working and standing space entirely on the property of the customer is to be provided in front of all meters and service equipment. Service equipment is defined as any termination enclosure, metering and/or disconnect device and distribution equipment required to provide service.

The working space is to be kept clear, level and unobstructed. It must extend a minimum of 3 feet from the face of any and all service equipment for services of 240 volts or less. Consult NEC for higher voltage requirements. The width of the working space shall permit ready access to the complete service equipment installation and in no case be less than 3 feet.

The height clearance for the working space shall be no less than 6 feet 6 inches as measured from the clear, level and unobstructed work surface to any overhead obstruction. For the working space and clearance requirements in meter rooms for 0-300 volts services, see **MTR-DWG-007**.

A minimum of 3 feet of clear, level, unobstructed work space is required in front of all termination, metering, service equipment and any Fiber Optic patch panel.

A “housekeeping pad” is required whenever the service equipment is subject to flooding. When the service equipment is installed on a “housekeeping pad”, the pad shall be flush with the service equipment or extend in front of the service equipment by a distance equal to the minimum working space and clearance required by NEC. In no case shall the maximum meter height of 6 feet 3 inches be exceeded.

To maintain a safe, clear and level working area in front of new or existing meter and service equipment, a concrete slab or other suitable permanent surface, acceptable to GWP, is required.

For higher voltage service installations, contact GWP.

Service Entrance Grounding and Bonding Diagrams

Prepared by

The Southwestern Section
International Association of Electrical Inspectors
2005 Grounding and Bonding Committee

William Brownell, P.E., Chairman

Scott Davis

Nader Shams, P.E.

Gary Gonzales

Ron Takiguchi, P.E.

Jim Moore

Tom Trainor

Timothy Owens

Gerald Williams

Steve Schinko

Based on the 2005 National Electrical Code

These diagrams are intended to illustrate typical grounding and bonding requirements but are not intended to show the only acceptable grounding and bonding methods.

COMBINATION METER AND SERVICE SECTION FOR OVERHEAD DWELLING SERVICE

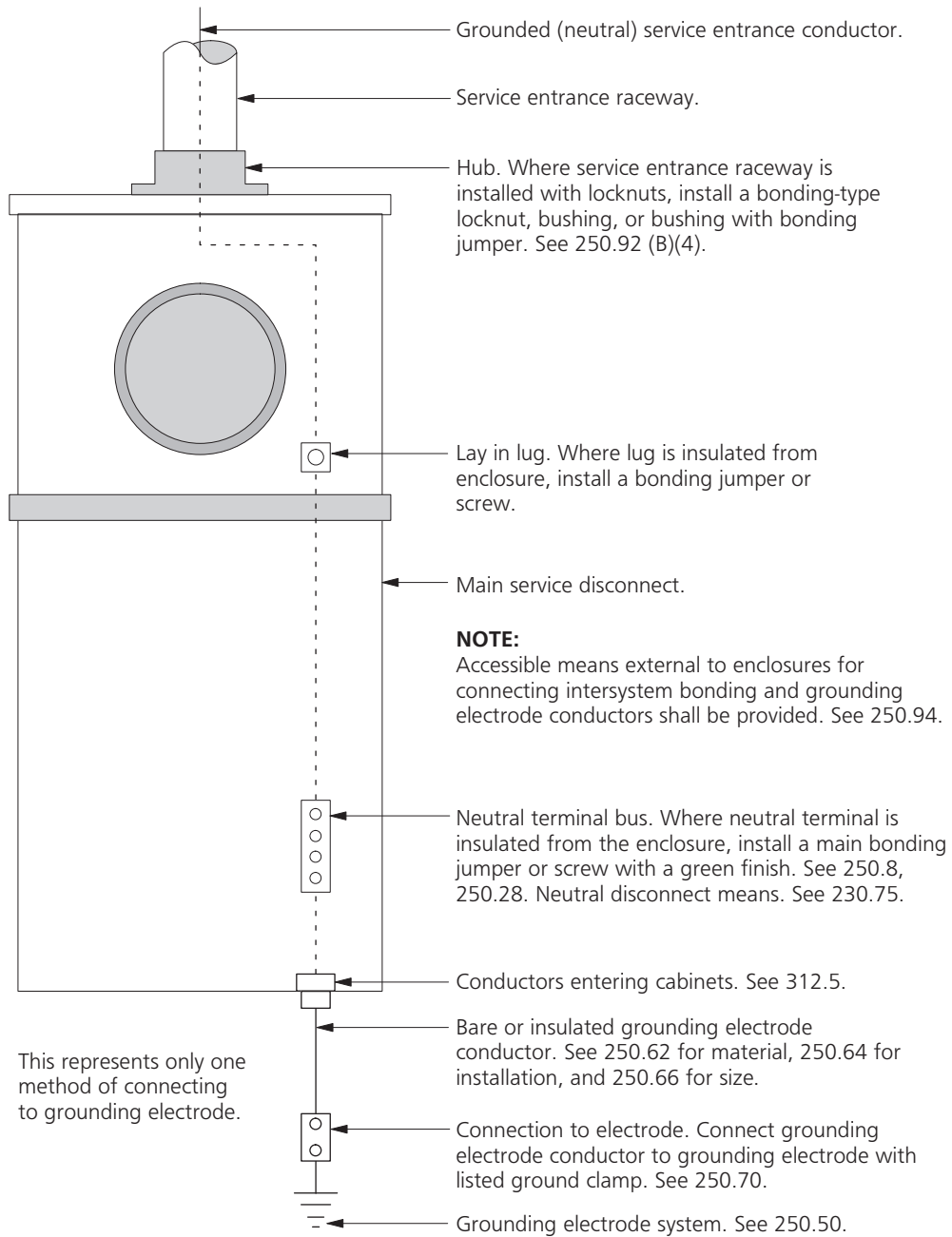

METER REMOTE FROM SERVICE SECTION FOR OVERHEAD DWELLING SERVICE

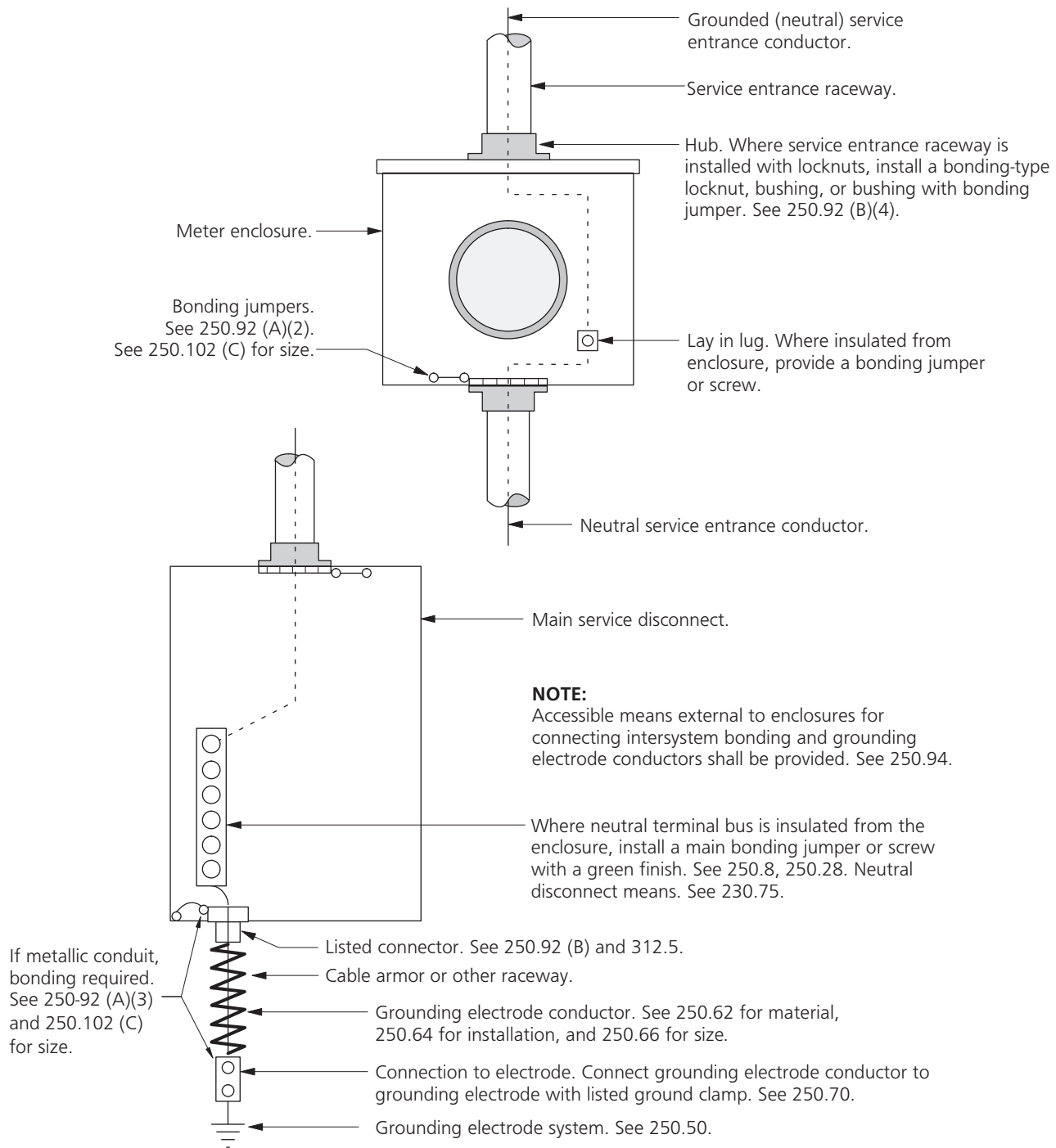

**METER AND SERVICE WITH
CURRENT TRANSFORMER ENCLOSURE
OVERHEAD SUPPLY**

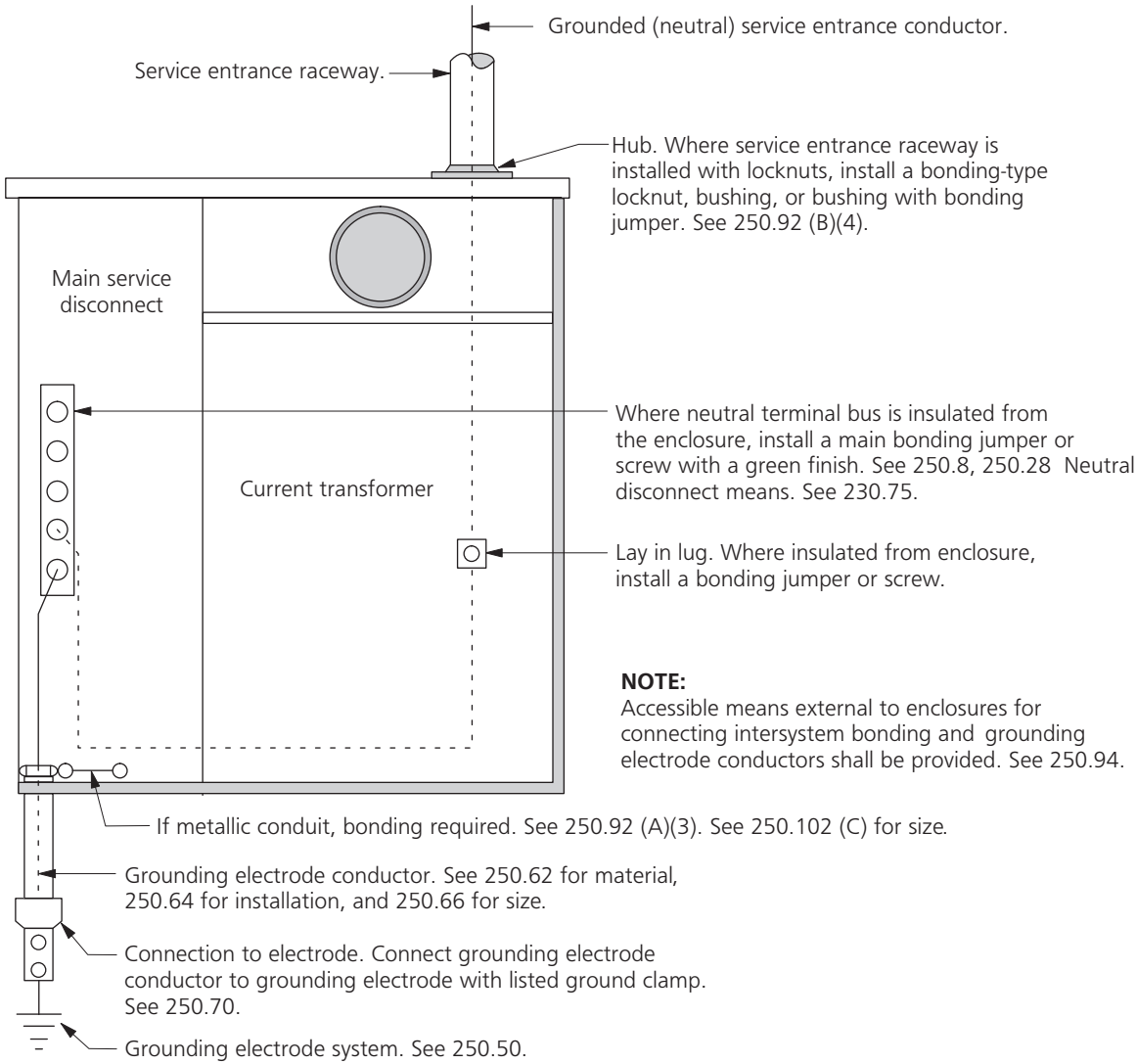

**SINGLE-METER COMMERCIAL SERVICE
WITH A NEUTRAL
(WHERE A MAIN DISCONNECTING MEANS IS REQUIRED)**

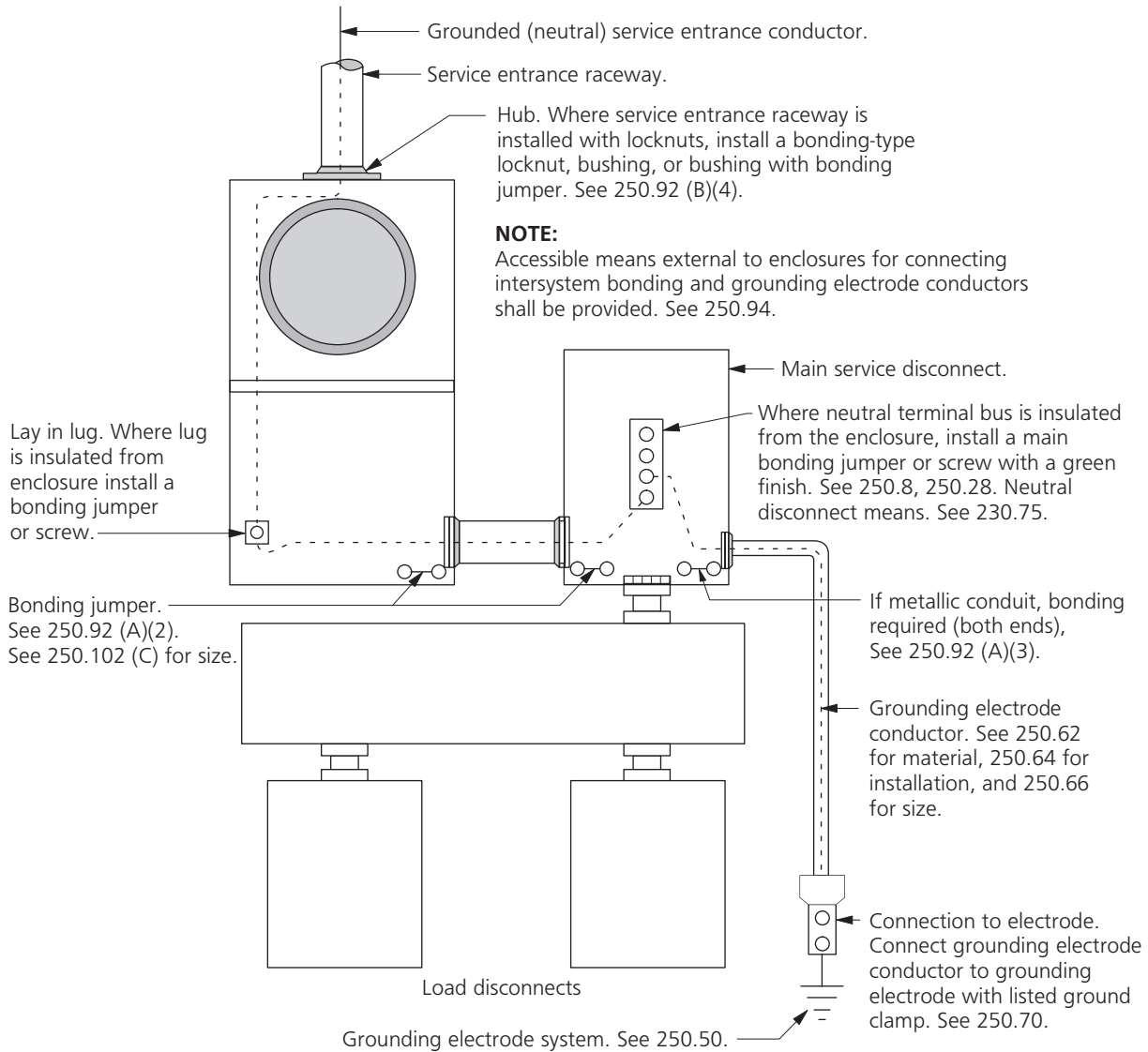

THREE-PHASE, THREE-WIRE DELTA SERVICE WITH ADDED GROUNDING CONDUCTOR¹ (CORNER GROUND DELTA)

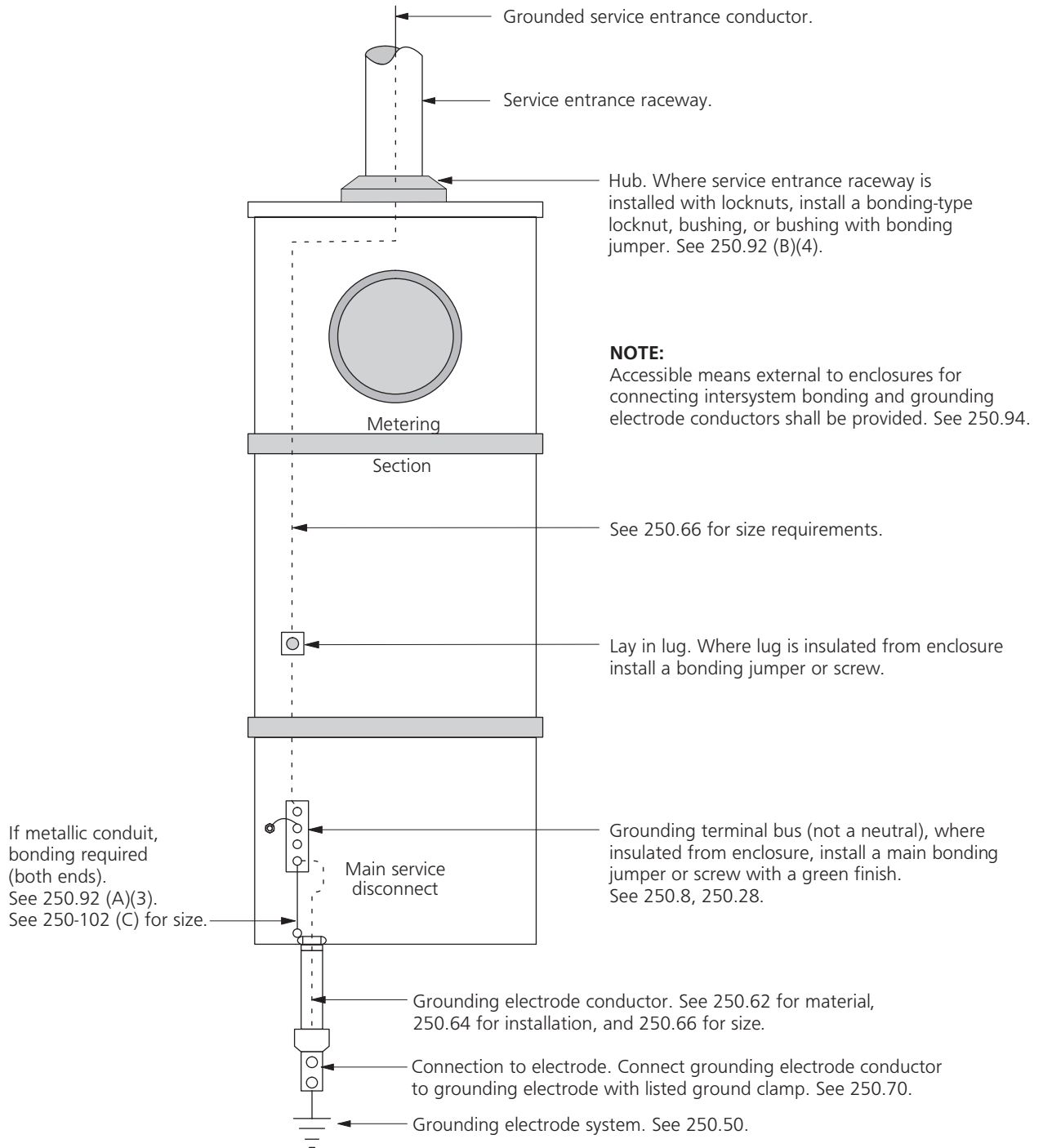

^{1/} Serving utility MUST be consulted for service transformer connections and transformer grounding to determine appropriate equipment ratings/application.

**COMMERCIAL SERVICE
OVERHEAD SUPPLY
SIX SUBDIVISIONS OR LESS**

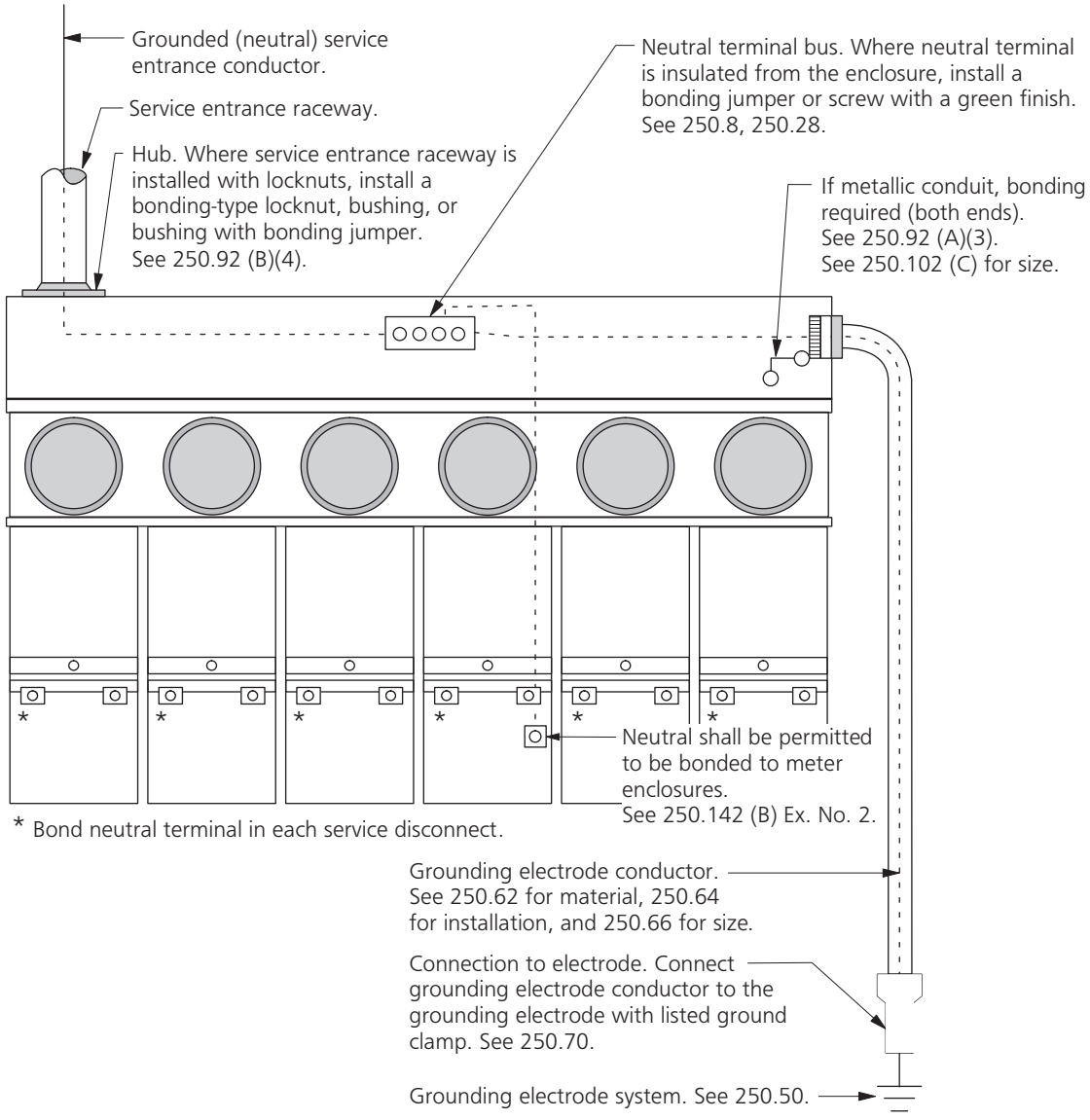

NOTE:
Accessible means external to enclosures for connecting intersystem bonding and grounding electrode conductors shall be provided. See 250.94.

**COMMERCIAL SERVICE
OVERHEAD SUPPLY
MORE THAN SIX SUBDIVISIONS OF SERVICE**

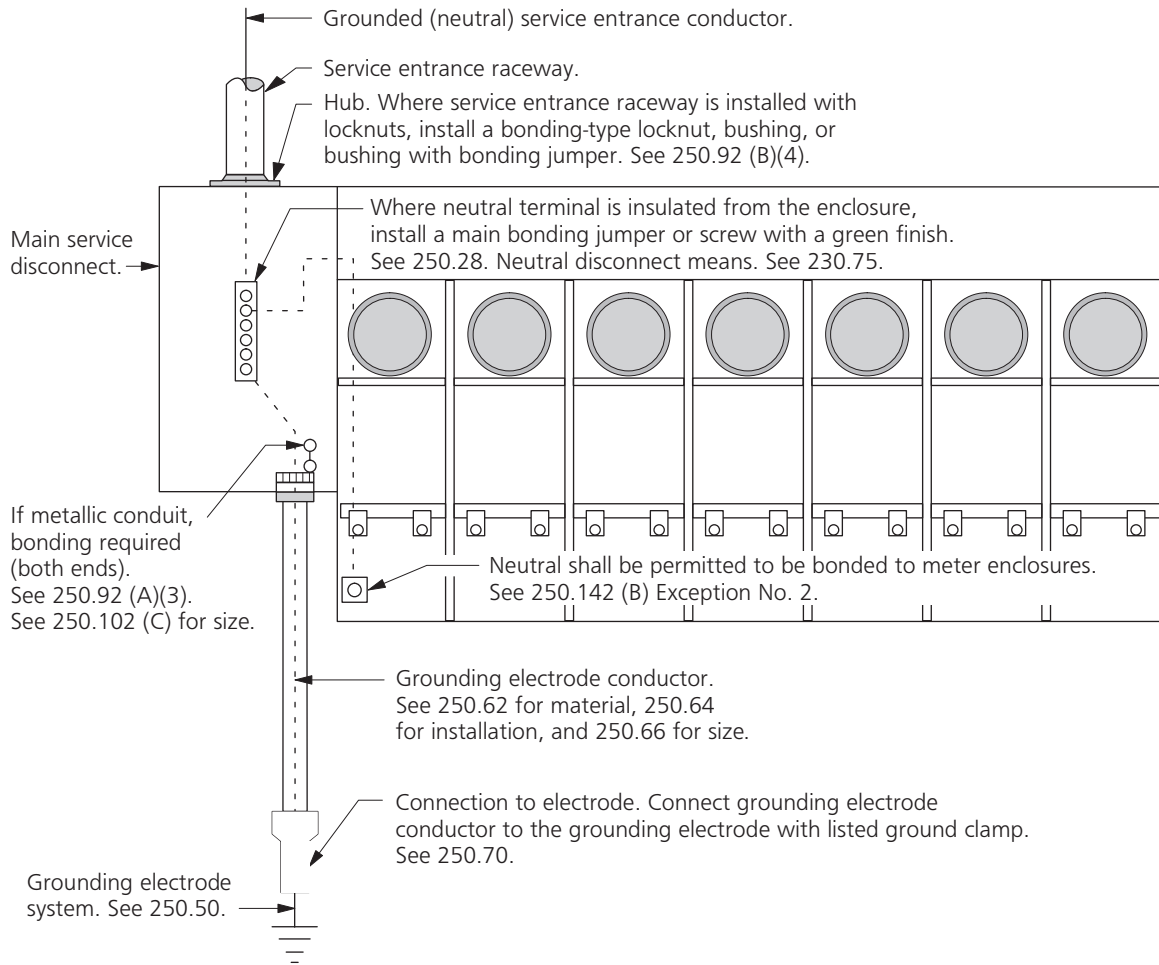

NOTE:
Accessible means external to enclosures for connecting intersystem bonding and grounding electrode conductors shall be provided. See 250.94.

COMBINATION METER AND SERVICE FOR UNDERGROUND DWELLING SERVICE

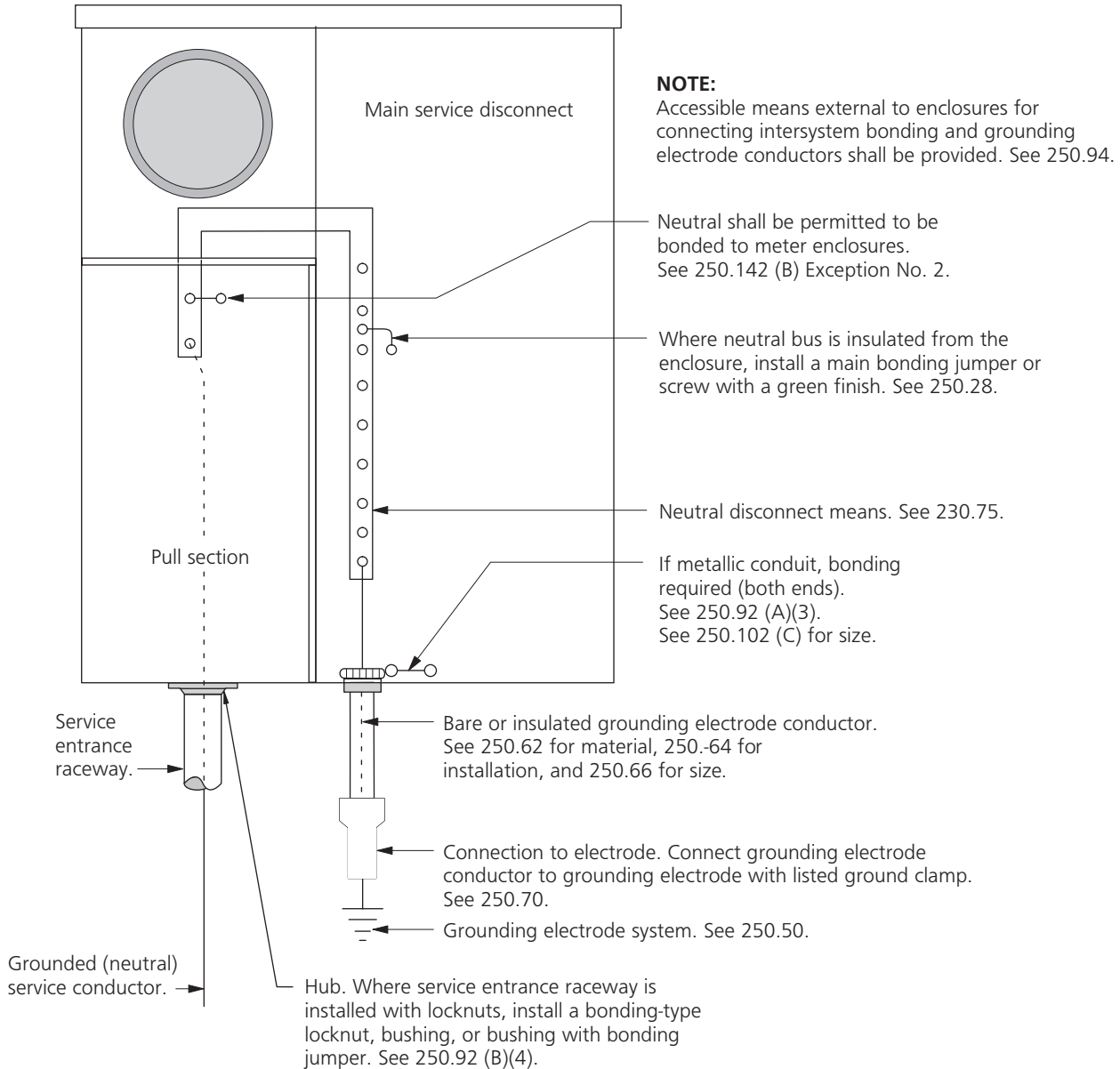

**COMBINATION METER AND SERVICE FOR
UNDERGROUND MULTI-FAMILY DWELLING SERVICE
SIX SUBDIVISIONS OF SERVICE OR LESS**

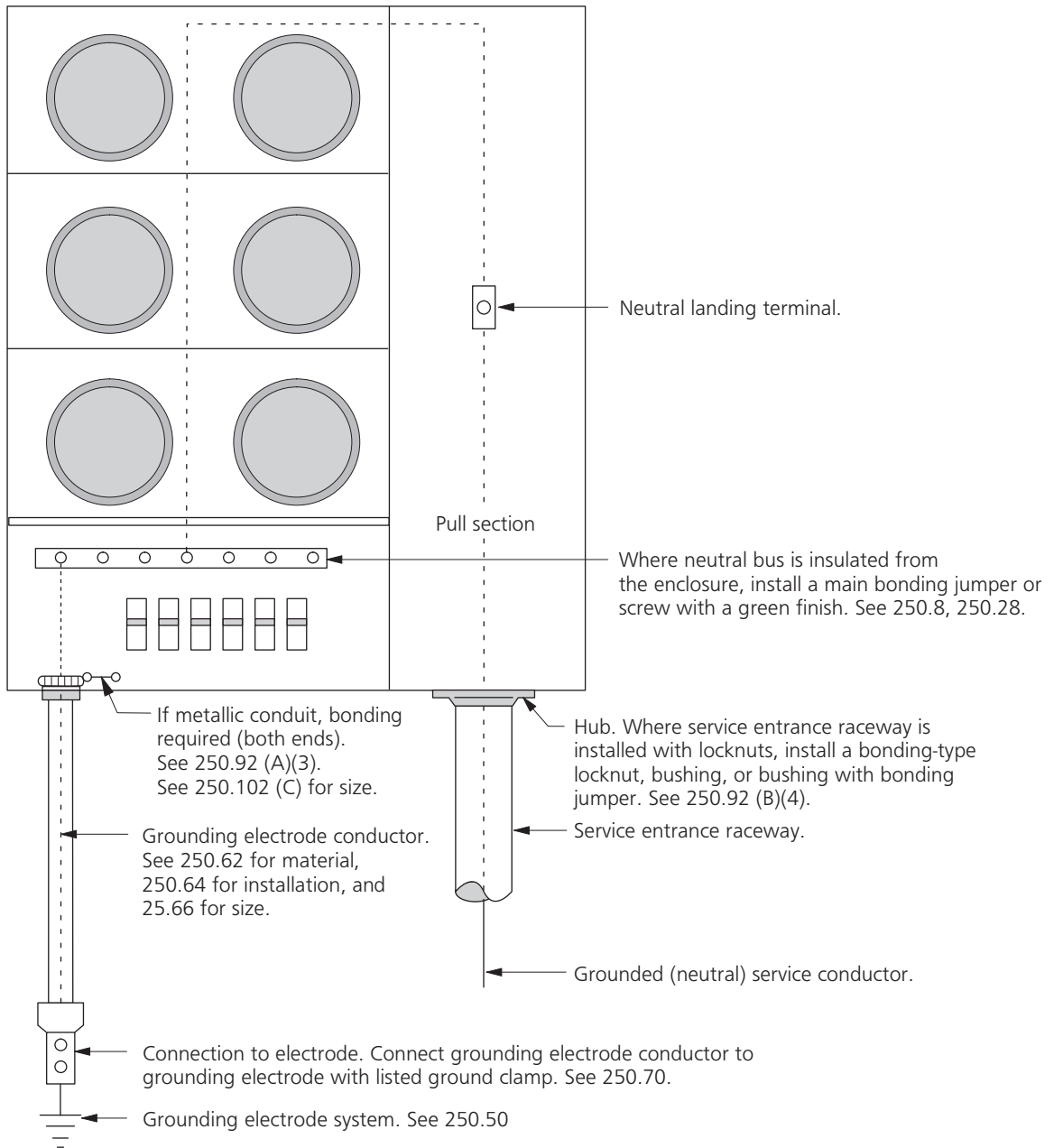

NOTE:

Accessible means external to enclosures for connecting intersystem bonding and grounding electrode conductors shall be provided, see 250.94.

**COMBINATION METER AND SERVICE FOR
UNDERGROUND MULTI-FAMILY DWELLING SERVICE
MORE THAN SIX SUBDIVISIONS**

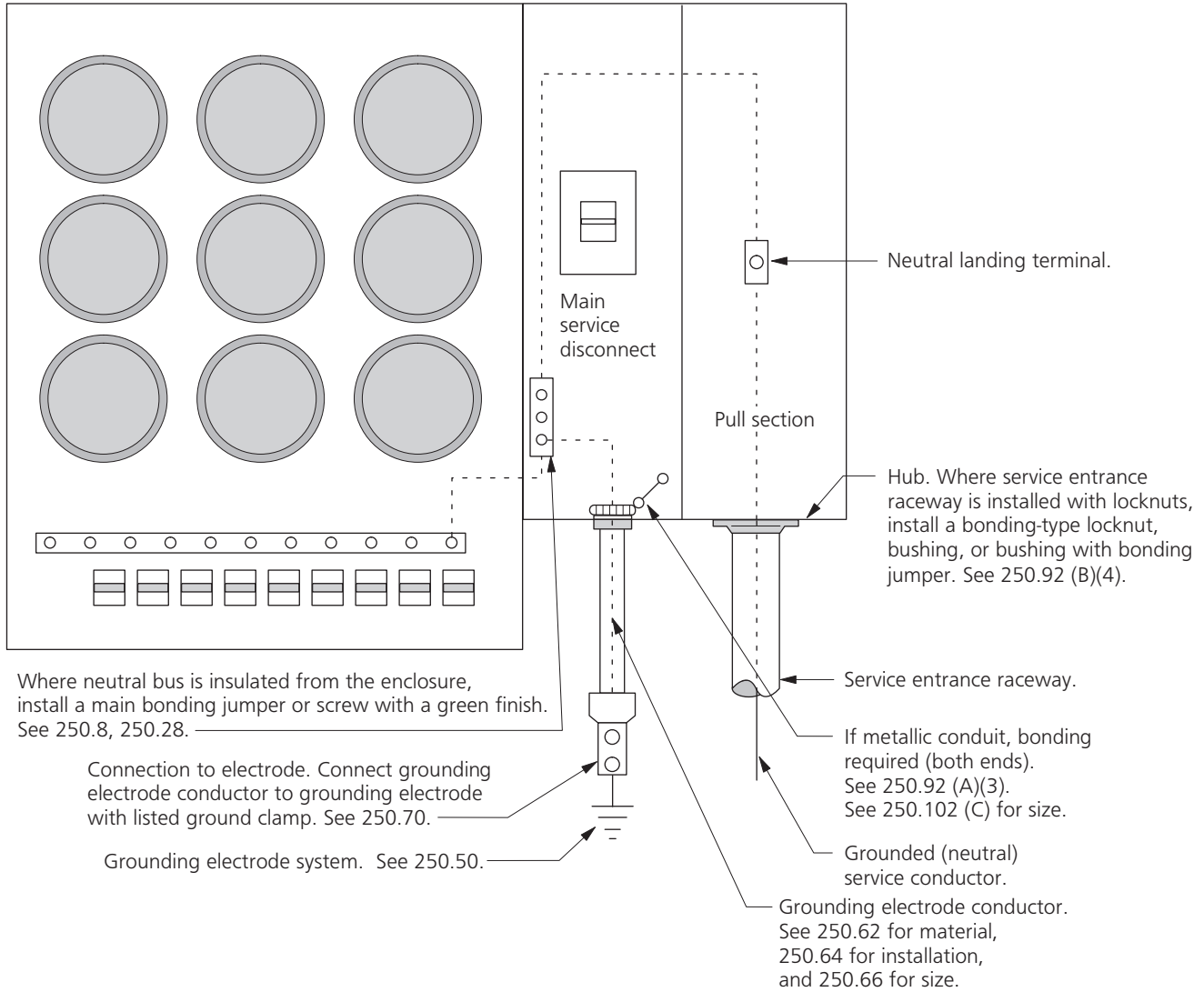

NOTE:
Accessible means external to enclosures for connecting intersystem bonding and grounding electrode conductors shall be provided. See 250.94.

COMBINATION METER AND SERVICE FOR UNDERGROUND COMMERCIAL SERVICE SIX SUBDIVISIONS OR LESS

If metallic conduit, bonding required (both ends).
See 250.92 (A)(3).
See 250.02 (C) for size.

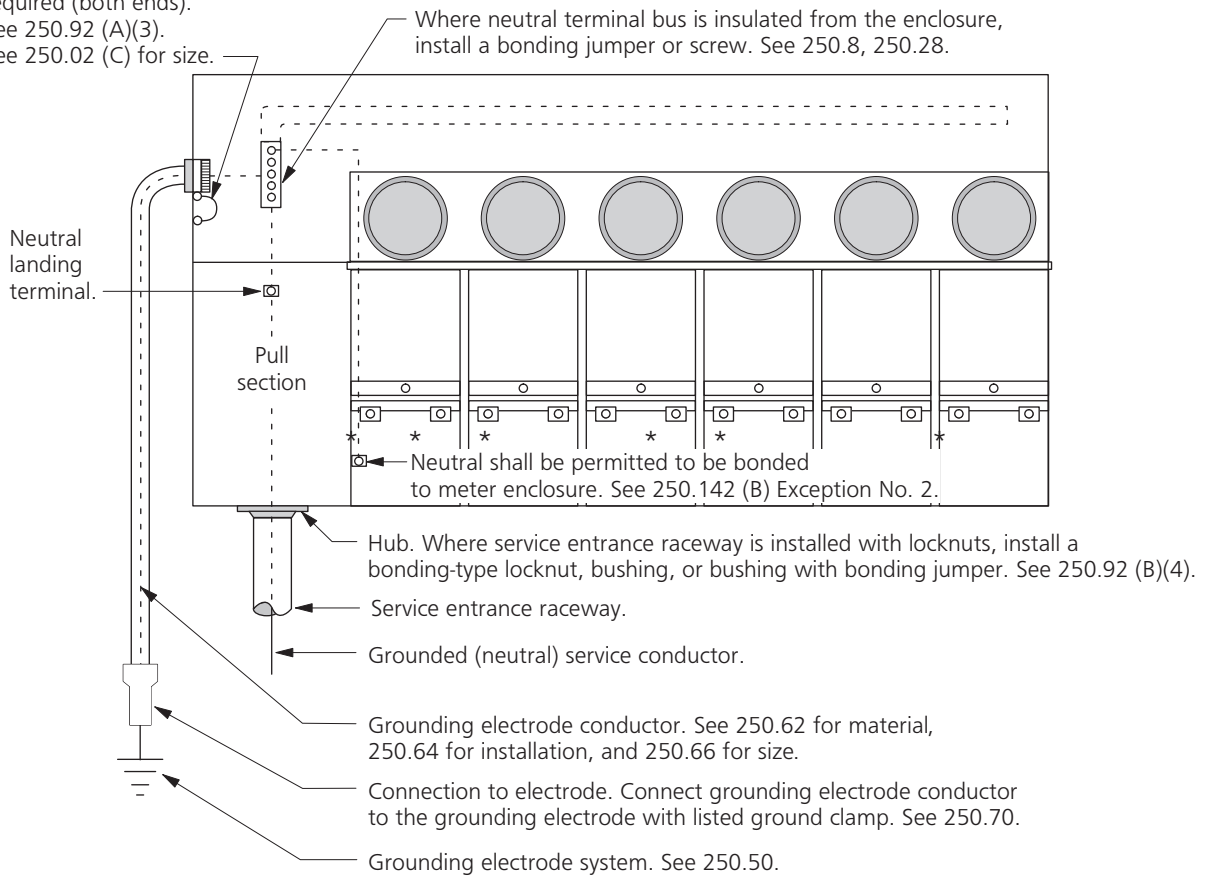

* Bond neutral terminal in each service disconnect.

NOTE:

Accessible means external to enclosures for connecting intersystem bonding and grounding electrode conductors shall be provided. See 250.94.

COMBINATION METER AND SERVICE FOR UNDERGROUND COMMERCIAL SERVICE MORE THAN SIX SUBDIVISIONS OF SERVICE

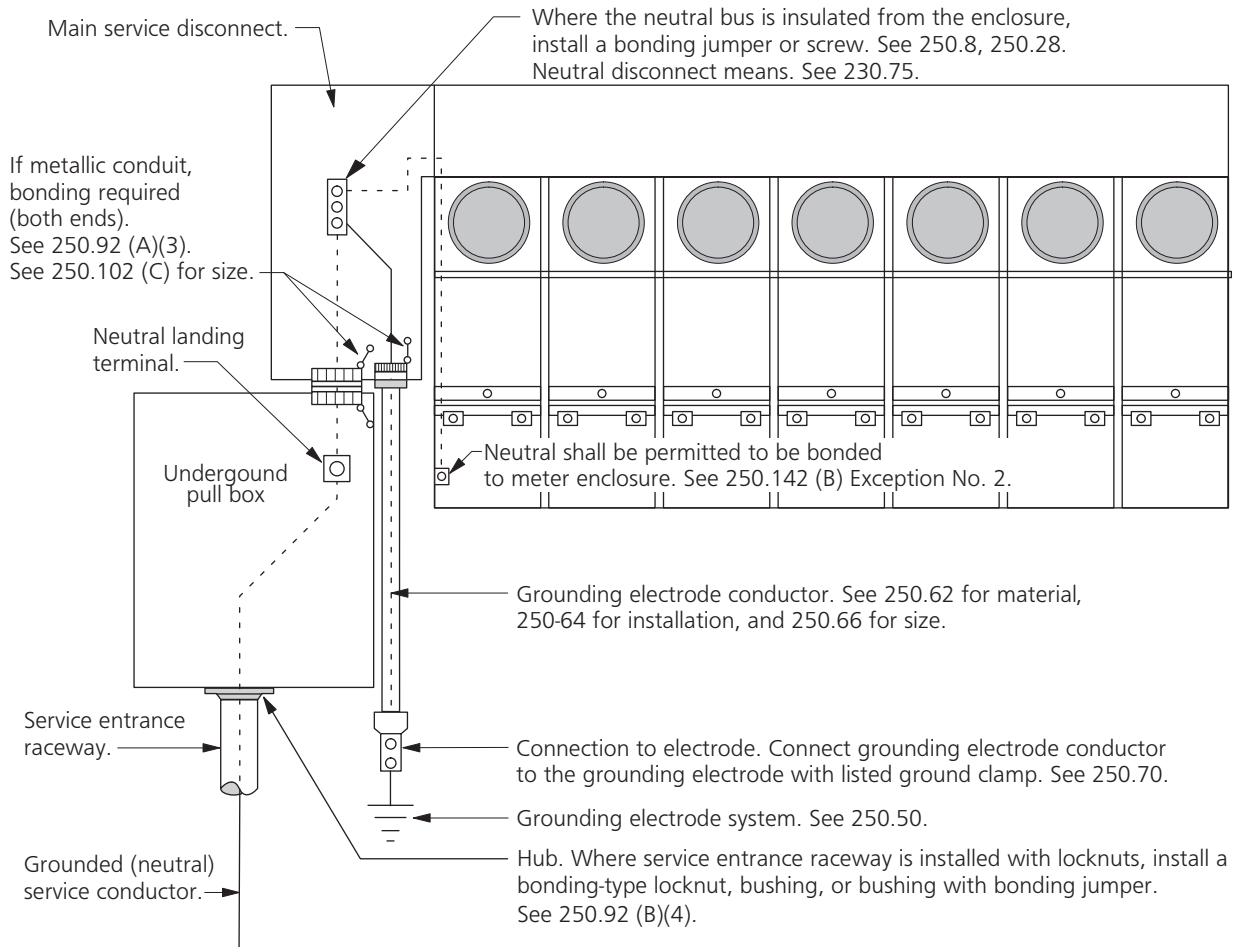

NOTE:

Accessible means external to enclosures for connecting intersystem bonding and grounding electrode conductors shall be provided. See 250.94.

SWITCHBOARD SERVICE SECTION

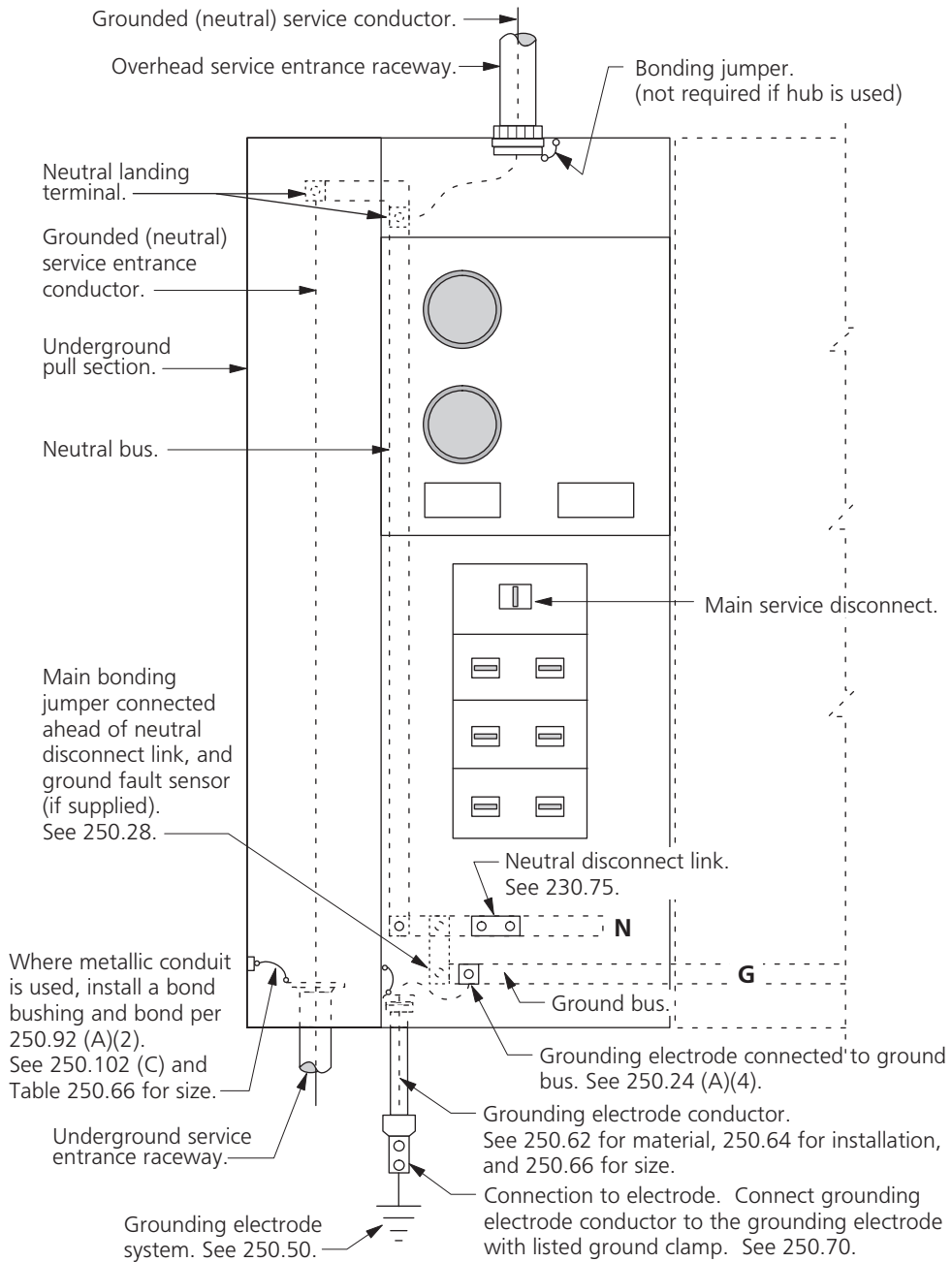

UNDERGROUND SERVICE POST

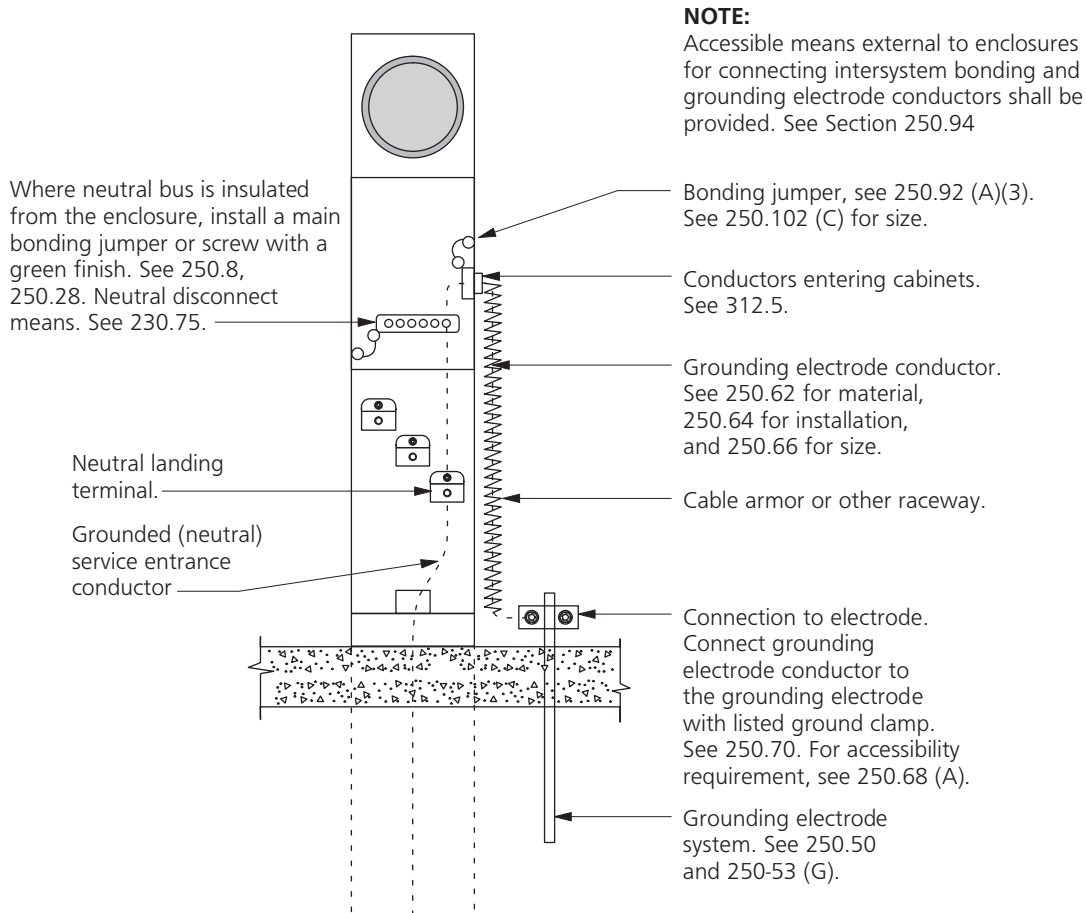

CONCRETE-ENCASED ELECTRODE (UFER GROUND)

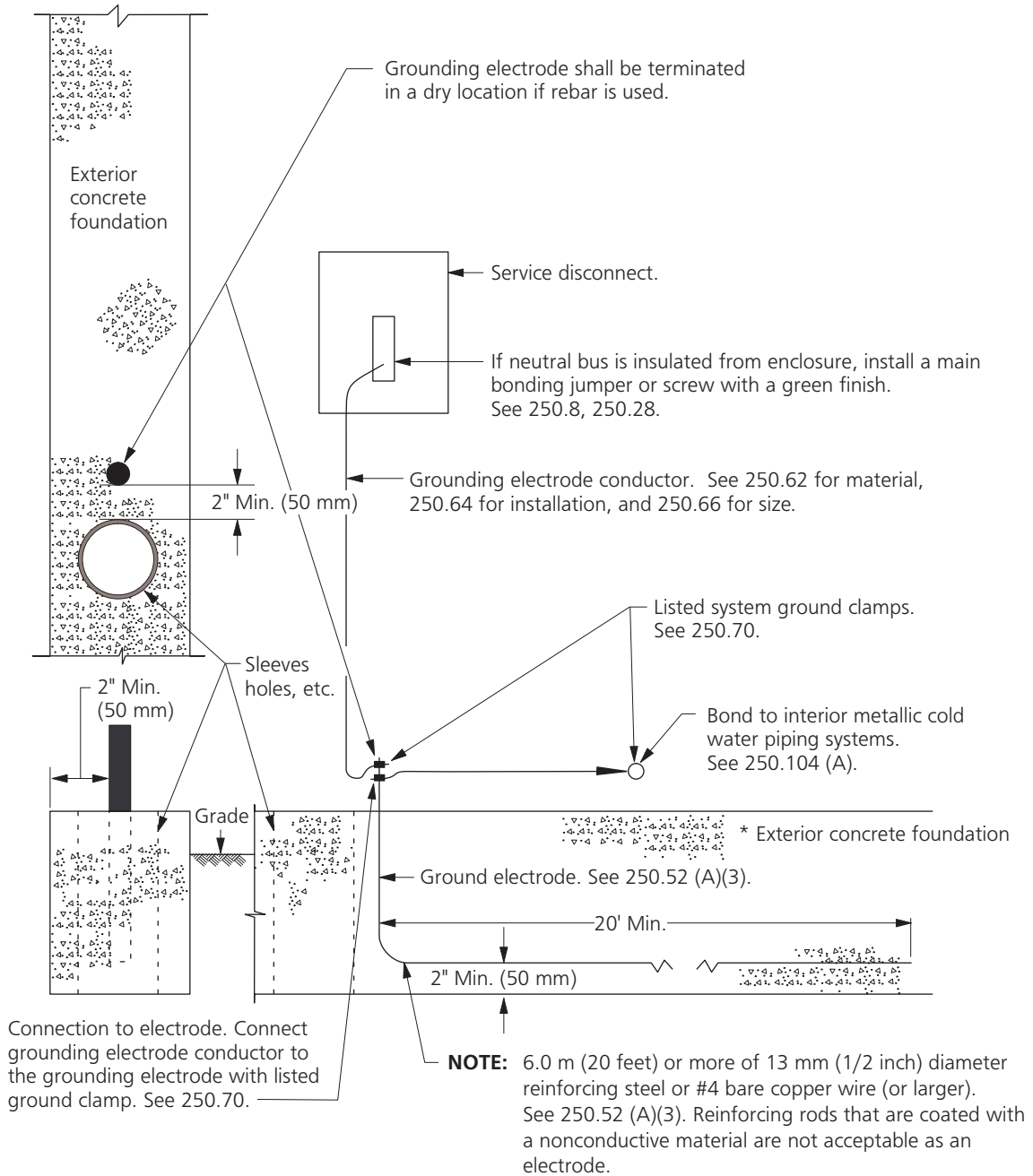

See the **Grounding and Bonding Pamphlet** for a thorough explanation of the grounding electrode system.

**SEPARATELY DERIVED SYSTEM
GROUNDING AND BONDING
(CUSTOMER'S TRANSFORMER)**

Single Phase

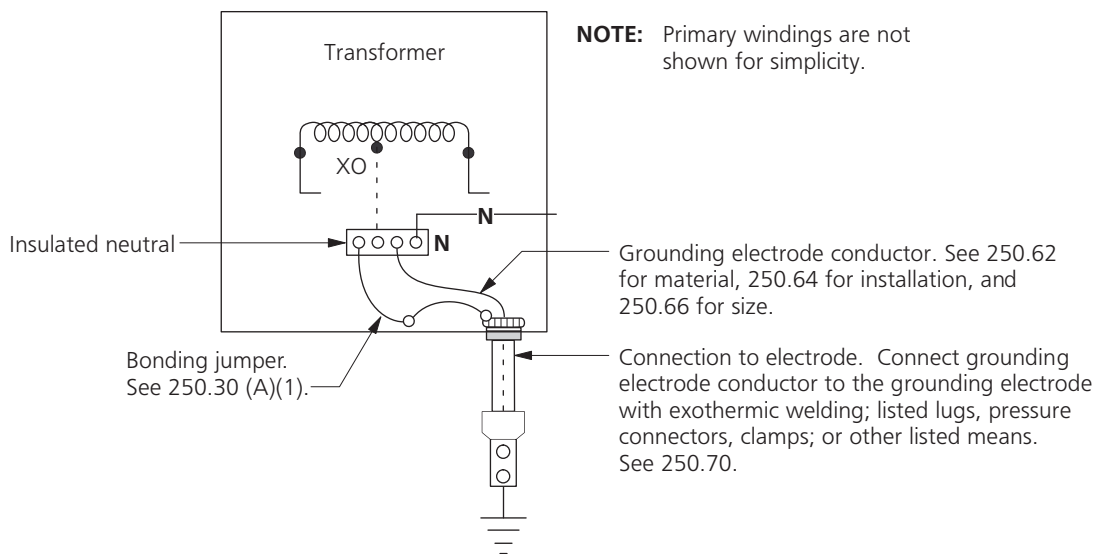

Grounding Electrode. See 250.50 and 250.30 (A)(7). Use the nearest of:

(1) Metal water pipe grounding electrode

OR

(2) Structural metal grounding electrode

Grounding Electrode Conductor.

See 250.30 (A)(3) for a single separately derived system.

See 250.30 (A)(4)(a), (b) and (c) for Common Grounding Electrode Conductor and Grounding Electrode Conductor Taps permitted from each separately derived system.

NOTES:

1. Primary winding are not shown for simplicity.
2. Grounding and bonding connection as shown above are permitted to be made at any point between the transformer secondary and the first disconnecting means. See 250.30 (A)(1). Exception No. 2 permits bonding at both source and first disconnecting means if no parallel path is established for grounded circuit conductor. Earth is not considered a parallel path.

**SEPARATELY DERIVED SYSTEM
GROUNDING AND BONDING
(CUSTOMER'S TRANSFORMER)**

Three-Phase, Four-Wire Wye

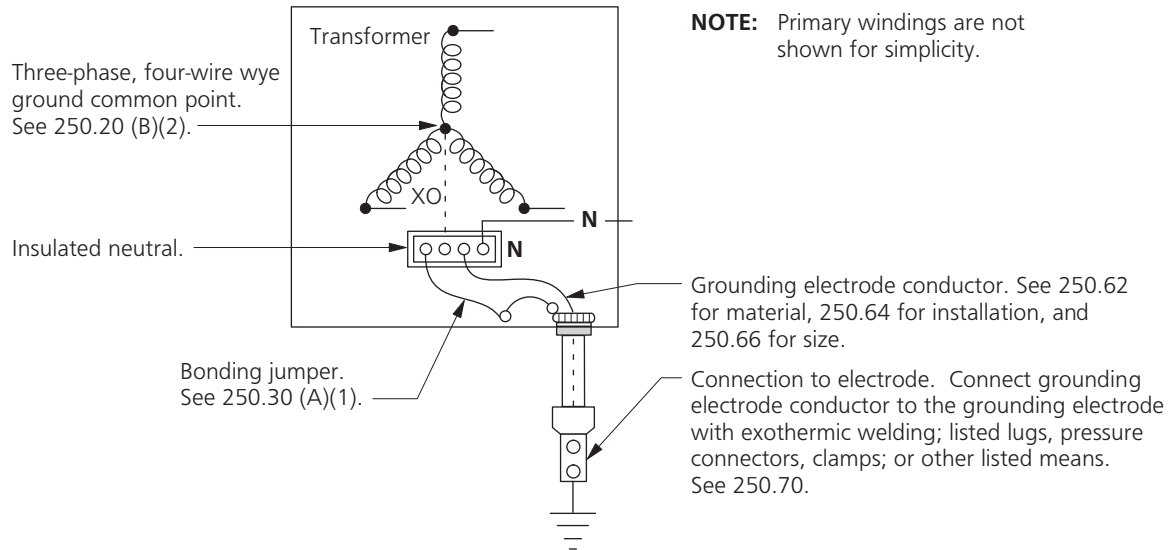

NOTE: Primary windings are not shown for simplicity.

Grounding Electrode. See 250.50 and 250.30 (A)(7). Use the nearest of:
 (1) Metal water pipe grounding electrode
OR
 (2) Structural metal grounding electrode

Grounding Electrode Conductor.
 See 250.30 (A)(3) for a single separately derived system.
 See 250.30 (A)(4)(a), (b) and (c) for Common Grounding Electrode Conductor and Grounding Electrode Conductor Taps permitted from each separately derived system.

- NOTES:**
1. Primary windings are not shown for simplicity.
 2. Grounding & bonding connections as shown above are permitted to be made at any point between the transformer secondary and the first disconnecting means. See 250-30 (A)(1). Exception No. 2 permits bonding at both source and first disconnecting means if no parallel path is established for grounded circuit conductor. Earth is not considered a parallel path.

se g&b diagrams 2005.fm, 080930.1347

**SEPARATELY DERIVED SYSTEM
GROUNDING AND BONDING
(CUSTOMER'S TRANSFORMER)**

Three-Phase, Four-Wire Delta High-Leg

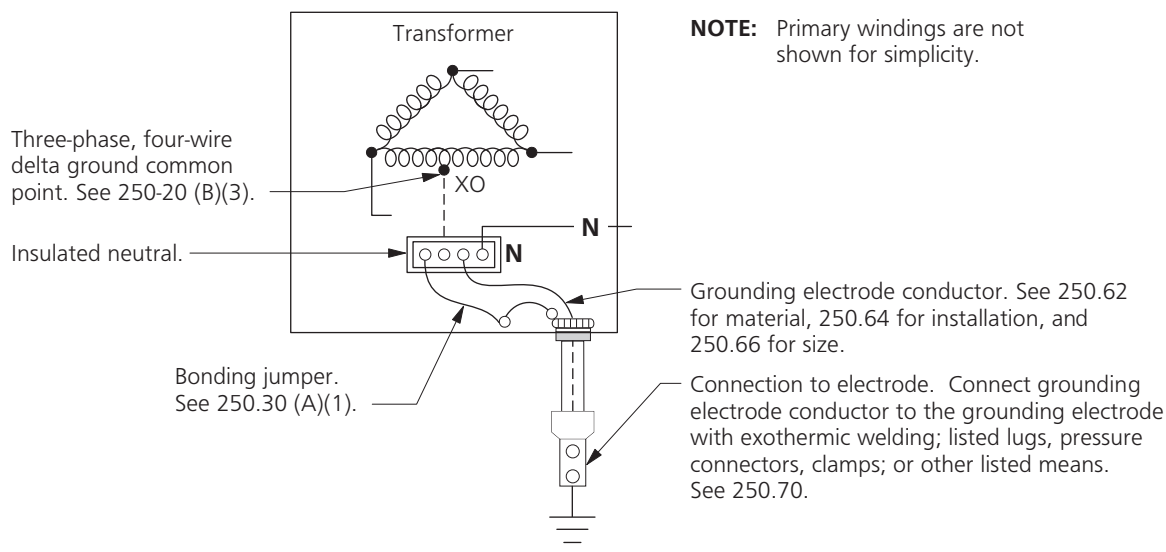

NOTE: Primary windings are not shown for simplicity.

Grounding Electrode. See 250.50 and 250.30 (A)(7). Use the nearest of:
(1) Metal water pipe grounding electrode
OR
(2) Structural metal grounding electrode

Grounding Electrode Conductor.
See 250.30 (A)(3) for a single separately derived system.
See 250.30 (A)(4)(a), (b) and (c) for Common Grounding Electrode Conductor and Grounding Electrode Conductor Taps permitted from each separately derived system.

NOTES:

1. Primary windings are not shown for simplicity.
2. Grounding & bonding connections as shown above are permitted to be made at any point between the transformer secondary and the first disconnecting means. See 250.30 (A)(1). Exception No. 2 permits bonding at both source and first disconnecting means if no parallel path is established for grounded circuit conductor. Earth is not considered a parallel path.

SEPARATELY DERIVED SYSTEM GROUNDING LOCATIONS

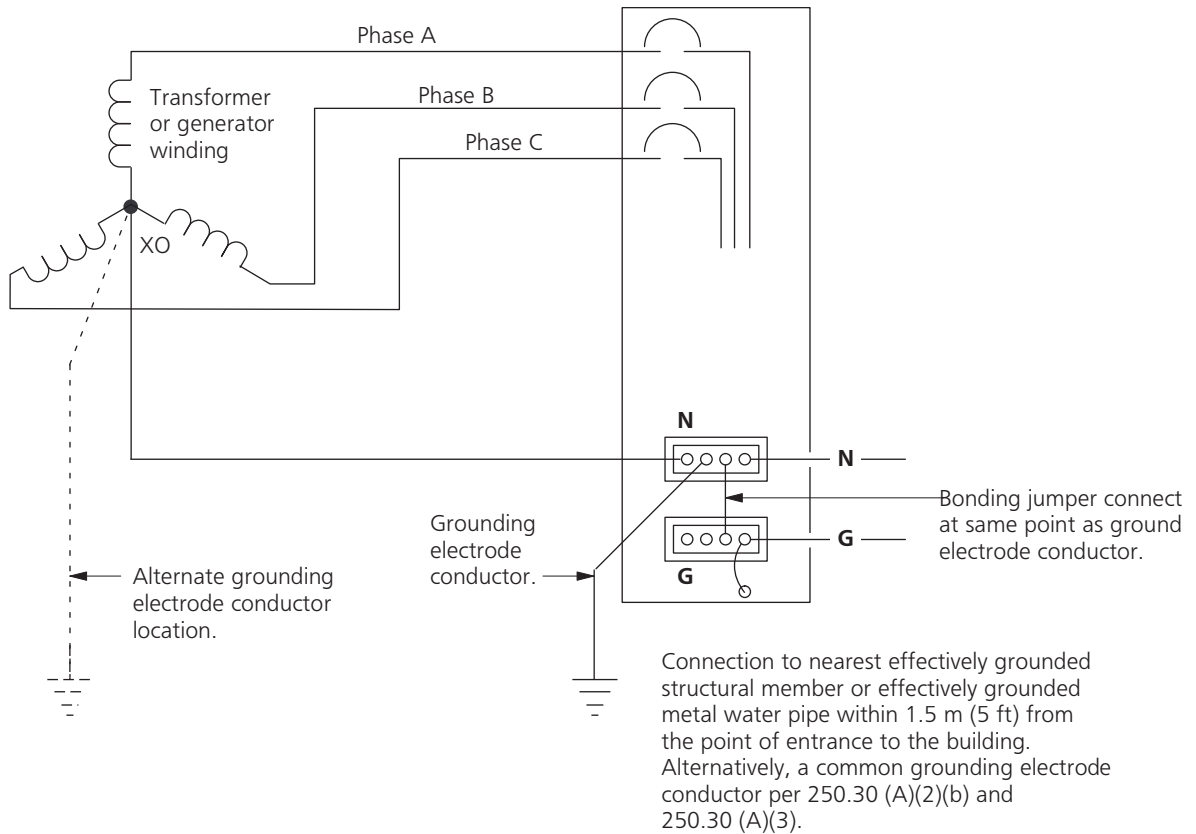

HIGH-IMPEDANCE GROUNDED NEUTRAL SYSTEM, SECTION 250.36

All of conditions (1), (2), (3), and (4) must be met:

- (1) Qualified persons.
- (2) Continuity of power is required.
- (3) Ground detectors are installed.
- (4) No line-to-neutral loads are served.

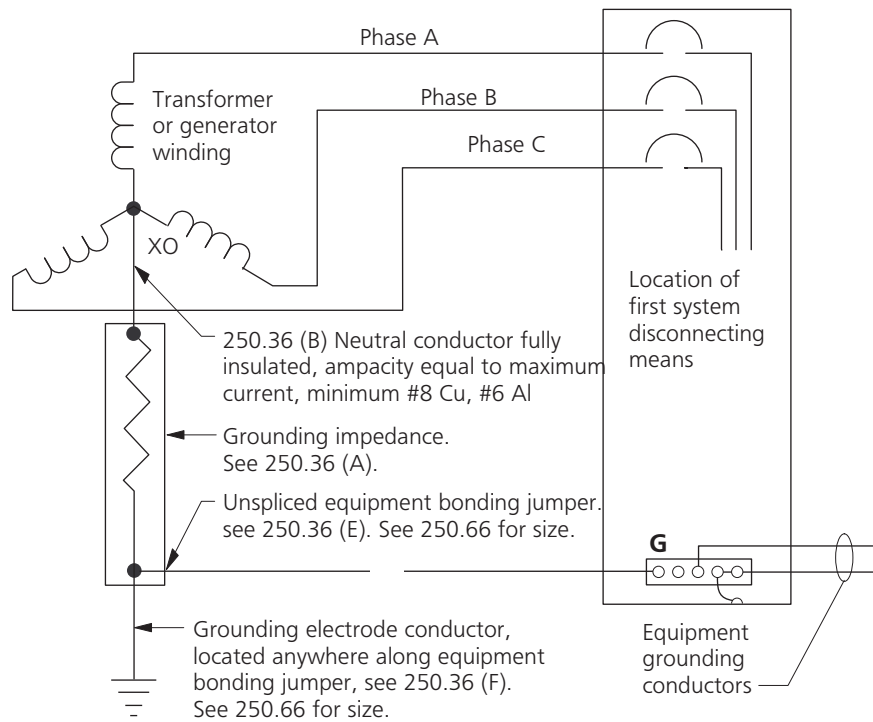

SERVICE 1 OF 2

3/4"
MIN.

THERE IS (1) OTHER SERVICE ON THIS BUILDING AS SHOWN BELOW. THE SHADED AREA INDICATES THE AREA CONTROLLED BY SERVICE 1 OF 2

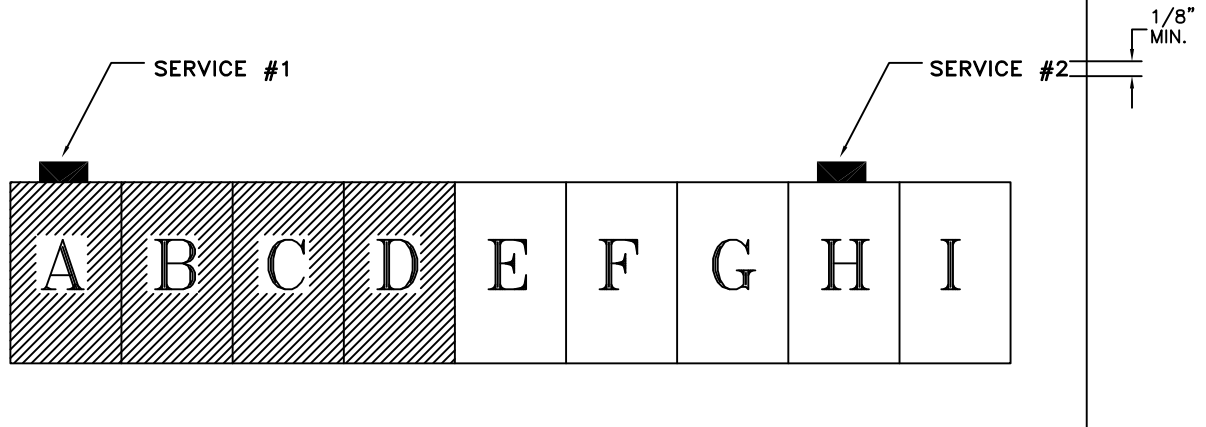

Notes:

1. THE PLAQUE MATERIAL SHALL BE PHONOLIC OR GLASTIC ONLY
2. THE PLAQUE SHALL BE ENGRAVED ONLY, MARKERS AND PRINTS ARE NOT ACCEPTABLE

| DATE | REV. | DESCRIPTION | BY | CHK'D | APP. |
|------|------|-------------|----|-------|------|
| | | | | | |



REV. NO. 1
DATE 08/28/01
DRAWN BY CB/HRA
APPROVED BY:HRA

CITY OF GLENDALE WATER & POWER

TYPICAL PLAQUE
DIRECTORY SPECIFICATIONS

MTR-DWG-001
PAGE 1 of 1

CUSTOMER SERVICE ENGINEERING

SELF-CONTAINED & CURRENT TRANSFORMER METER SOCKET TERMINAL ARRANGEMENTS

| TYPE OF SERVICE | SELF-CONTAINED TERMINALS | CURRENT TRANSFORMER TERMINALS |
|---|--------------------------|-------------------------------|
| Single Phase 120 volt two-wire (EXISTING ONLY) | 4 Clip, Exhibit A | |
| Single Phase 240 volt three-wire | 4-Clip, Exhibit A | 6-Clip, Exhibit G |
| Single Phase 120 /208 volt three-wire | 5 Clip, Exhibit B or C | |
| Three Phase 240 volt three-wire ^(a) | 5 Clip, Exhibit B or C | 8 or 15-Clip, Exhibit E or F |
| Three Phase 480 volt three-wire | | 8 or 15-Clip, Exhibit E or F |
| Three Phase 120/208 volt four-wire | 7 Clip, Exhibit D | 15-Clip, Exhibit F |
| Three Phase 120/240 volt four-wire DELTA | 7 Clip, Exhibit D | 15-Clip, Exhibit F |
| Three Phase 277/480 volt four-wire | | 15-Clip, Exhibit F |
| Three Phase 4160/12470 kV four-wire | | 8 or 15-Clip, Exhibit E or F |
| Totalizing two, three-wire, single phase circuits | | 8 or 15-Clip, Exhibit E or F |
| Totalizing three, three-wire, single phase circuits | | 15-Clip, Exhibit F |

(a) One phase grounded, fourth-wire run for grounding purposes only per G.O. 95 rule 58.2A-1 or G.O. 128 rule 36.5A-1.

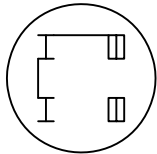

EXHIBIT A

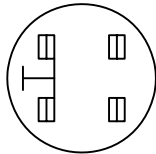

EXHIBIT B

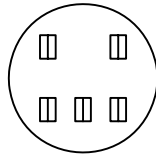

EXHIBIT C

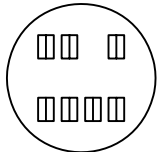

EXHIBIT D

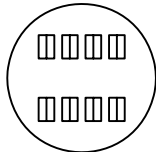

EXHIBIT E

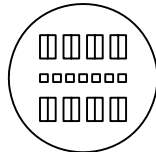

EXHIBIT F

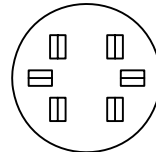

EXHIBIT G

| DATE | REV. | DESCRIPTION | BY | CHK'D | APP. |
|------|------|-------------|----|-------|------|
| | | | | | |



| | | |
|--|---|----------------------------|
| CITY OF GLENDALE WATER & POWER | | |
| REV. NO. DATE 01-14-05 DRAWN BY: BALUYOT APPROVED BY: HRA | SELF-CONTAINED & CURRENT TRANSFORMER METER SOCKET TERMINAL ARRANGEMENTS | MTR-DWG-002 PAGE 1 of 1 |
| CUSTOMER SERVICE ENGINEERING | | |

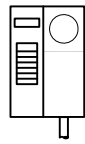

EXHIBIT A

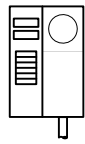

EXHIBIT B

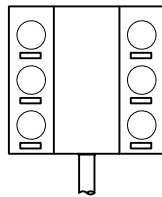

EXHIBIT C

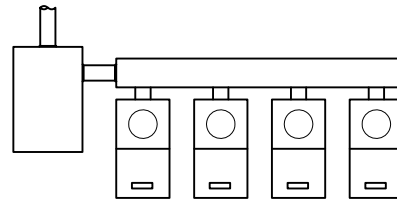

EXHIBIT D

SIX DISCONNECTS OR LESS

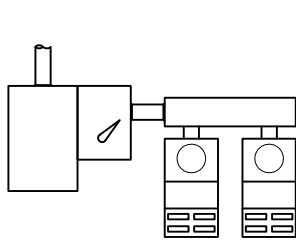

EXHIBIT E

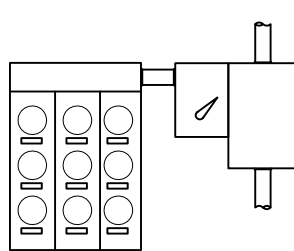

EXHIBIT F

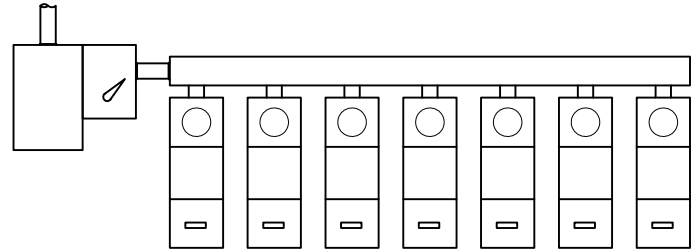

EXHIBIT G

MORE THAN SIX DISCONNECTS

NOTES

1. These illustrations are typical of overhead and underground residential and commercial metering configurations, but are not the only acceptable configurations.
2. A meter main disconnect shall be installed for each meter as detailed in Section MTR-102
3. A main disconnect shall be installed on the source side of a group of more than six disconnects, meter sockets, safety socket boxes, or instrument transformer boxes. See Exhibits E to G.
4. A main disconnect may be installed on the source side of a group of two to six meter sockets, safety socket boxes, or instrument transformer boxes where each meter has a single meter switch.
5. A main disconnect shall be installed on the source side of a group of two to six meter sockets, safety socket boxes, or instrument transformer boxes where groups of switches or breakers constitute the meter switches and the total number of such switches, or breakers, exceeds six. See Exhibits E to G.
6. The main disconnect may be a fused switch, or circuit breaker. Where fuses are installed, GWP assumes no responsibility for their replacement. Main disconnect enclosures shall be sealable. See Exhibits E to G.
7. Where a main disconnect is placed on the supply side of a group of meters, any equipment tapped ahead of the metering or disconnect shall be separately metered.
8. For each and every meter, the contractor shall furnish and install a main switch, or other approved disconnecting means with overcurrent protection. This is referred to as the "Main Switch". It shall be installed at the same location and directly adjacent to the metering and service equipment. The main switch shall control all of, and only the energy registered by that meter. A separate main switch will be required for each separate service, of any group where the loads are totaled by a single meter.

| DATE | REV. | DESCRIPTION | BY | CHK'D | APP. |
|------|------|-------------|----|-------|------|
| | | | | | |



CITY OF
GLENDALE
WATER & POWER

REV. NO.
DATE 07/24/00
DRAWN BY: BALUYOT
APPROVED BY: HRA

CITY OF GLENDALE WATER & POWER

METER SWITCHES AND MAIN DISCONNECTS

MTR-DWG-003
PAGE 1 of 1

CUSTOMER SERVICE ENGINEERING

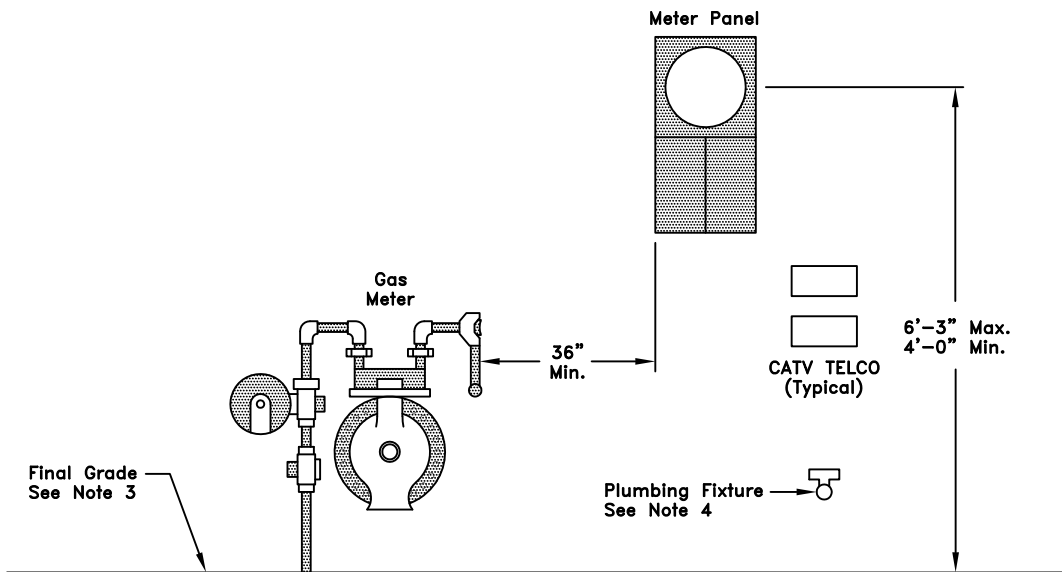
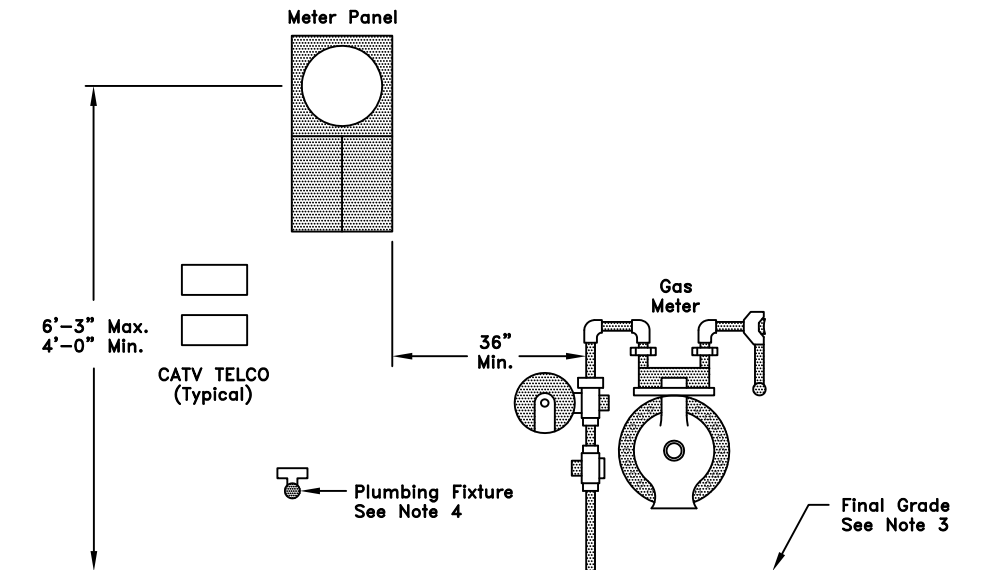

Notes

1. Size and dimensions of panels will vary. Drawings are not to scale.
2. This drawing pertains to both overhead and underground electric service applications.
3. Maintain 3 feet clear, level, and unobstructed work space in front of electric service equipment.
4. Plumbing fixtures which extend more than 6 inches out from wall surface must be located 18 inches minimum from the outside edge of the meter panel.

| DATE | REV. | DESCRIPTION | BY | CHK'D | APP. |
|--------|------|---|----|-------|------|
| 7/1/09 | 1 | CLEARANCE FROM GAS METERING EQUIPMENT TO ELECTRICAL PANEL | CC | PM | HRA |



CITY OF GLENDALE WATER & POWER

| | | |
|---|--|---|
| REV. NO. DATE 09/23/98 DRAWN BY: P MEZA APPROVED BY: HRA | SEPARATION OF METER ASSEMBLIES FOR ELECTRIC AND GAS SERVICES | MTR-DWG-004 PAGE 1 of 1 |
| CUSTOMER SERVICE ENGINEERING | | |

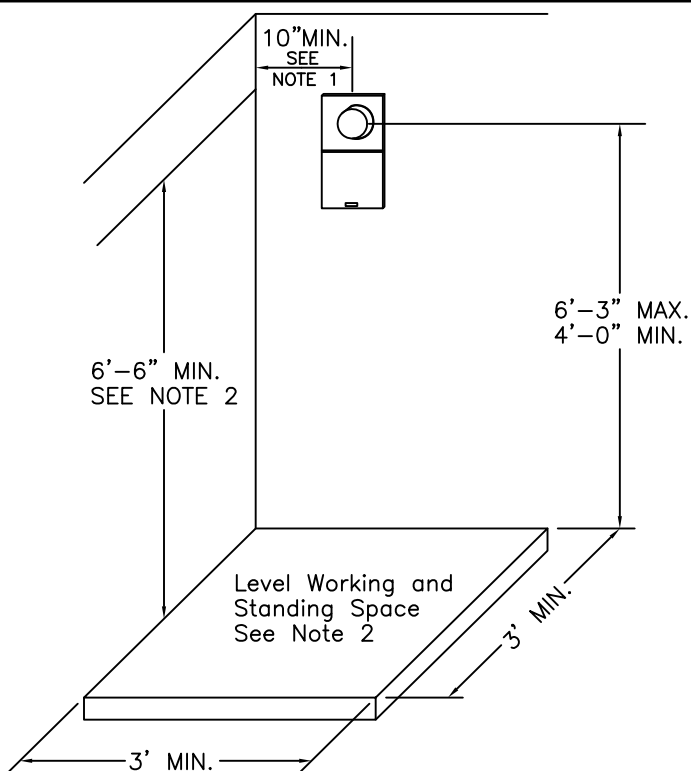

NOTES:

1. The horizontal clearance from the center line of the meter to the nearest side wall or other obstruction shall be 10 inches minimum. Any plumbing fixture which protrudes less than 6 inches from the wall shall not be considered an obstruction. A gas meter or gas pipe which extends more than 3 feet horizontally from the outside edge of the meter panel, shall not be considered an obstruction.
2. A level working and standing surface, clear and unobstructed, entirely on the property of the customer, shall be provided. The minimum width of the workspace shall be 36 inches overall, but need not be centered beneath the meter. The minimum depth of the workspace shall be 36 inches. Where meters are enclosed in a closet or enclosure, the depth of the workspace is measured from the outer face of the closet or recess. The minimum height of the workspace shall be 78 inches.

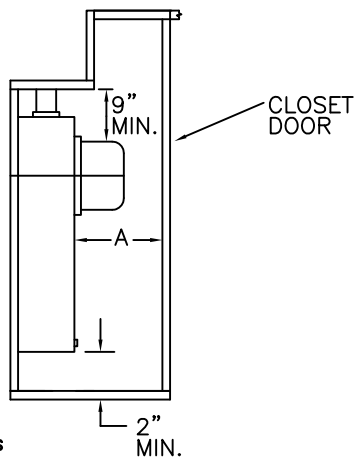
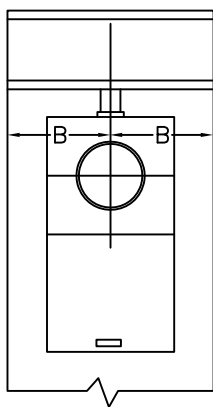

Minimum Enclosed Meter Clearances

| | A | B |
|-------------|-----|-----|
| Residential | 7" | 10" |
| Commercial | 11" | 10" |

| DATE | REV. | DESCRIPTION | BY | CHK'D | APP. |
|--------|------|--|----|-------|------|
| 7/1/09 | 1 | REVISED CLEARANCE FROM GAS METER IN NOTE #1. | CC | VMP | HRA |



REV. NO.
DATE 07/24/00
DRAWN BY
APPROVED BY:HRA

CITY OF GLENDALE WATER & POWER
WORKSPACE & METER CLEARANCES
(0 - 600V)

MTR-DWG-005
PAGE 1 of 1

CUSTOMER SERVICE ENGINEERING

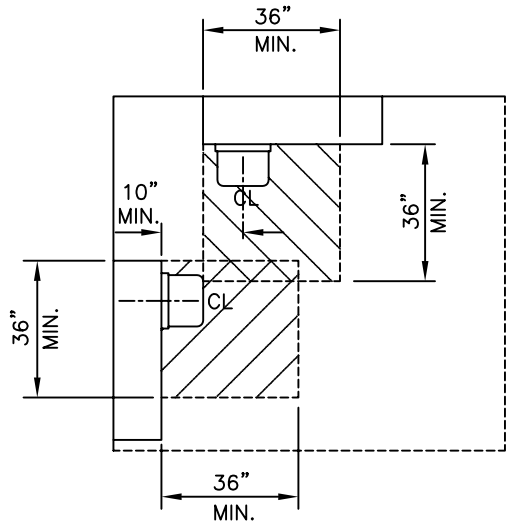

EXHIBIT A
PLAN VIEW

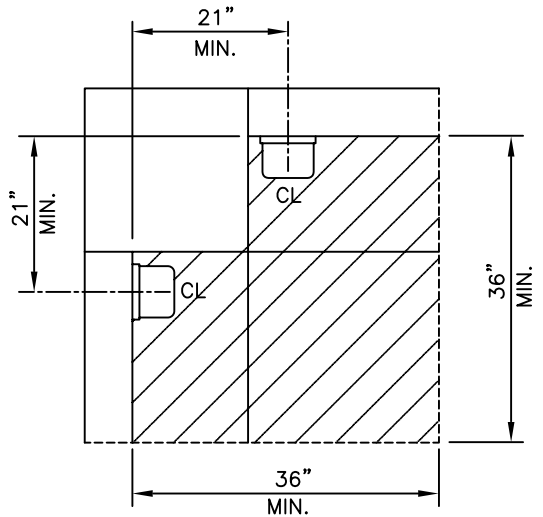

EXHIBIT B
PLAN VIEW

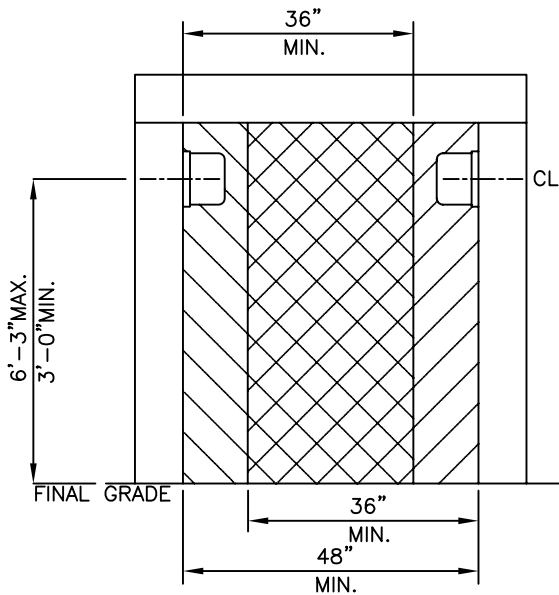

EXHIBIT C
SIDE VIEW

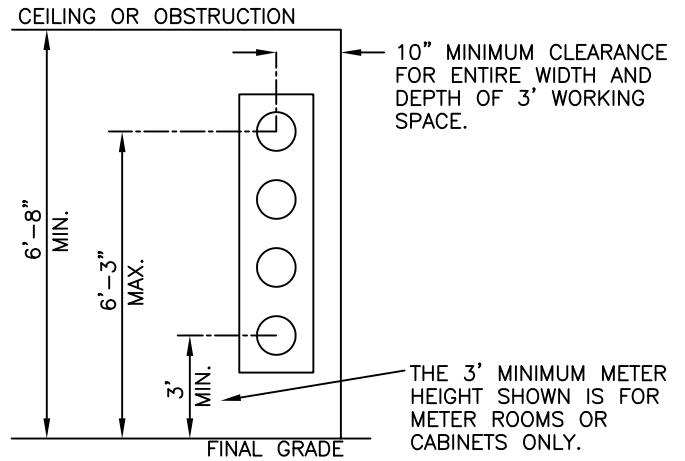

EXHIBIT D
FRONT VIEW

| DATE | REV. | DESCRIPTION | BY | CHK'D | APP. |
|---------|------|---|----|-------|------|
| 1/13/14 | 2 | REMOVED EUSERC 353 METER ROOM CLEARANCE TABLE | CC | VMP | VA |



REV. NO.
DATE 01-14-05
DRAWN BY
APPROVED BY: HRA

CITY OF GLENDALE WATER & POWER

METER ROOM CLEARANCES

MTR-DWG-006
PAGE 1 of 1

CUSTOMER SERVICE ENGINEERING

TOP VIEW OF SERVICE EQUIPMENT

WORKING SPACE & CLEARANCE REQUIREMENTS 0-300 VOLTS
(TOP VIEW OF SERVICE EQUIPMENT)

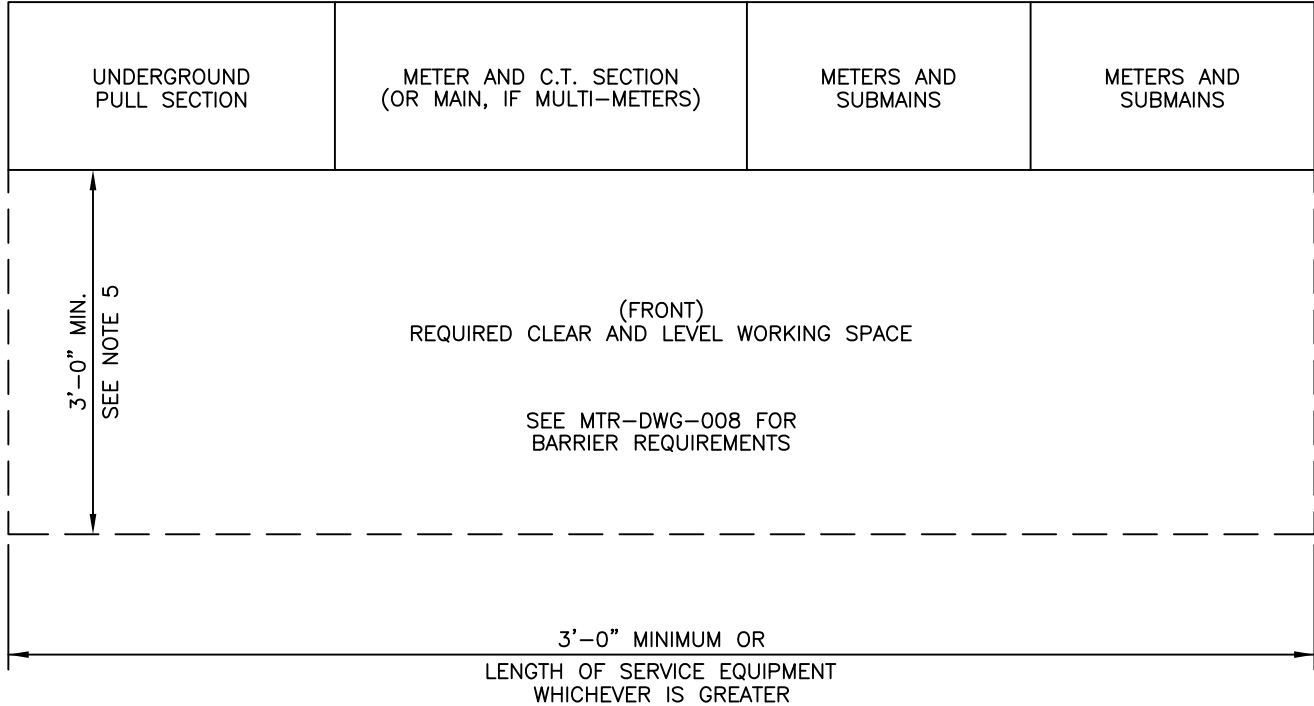

NOTE:

1. A minimum of 3 feet of clear, level unobstructed work space is required in front of all termination, metering and service equipment.
2. See MTR-DWG-006 and MTR-DWG-005 for meter mounting height requirements. Meter mounting height will be measured from the standing and working space to the center line of the meter(s).
3. A "housekeeping pad" is required whenever the service equipment is subject to flooding. When the service equipment is installed on a "housekeeping pad", the pad shall be flush with the service equipment or extend in front of the service equipment by a distance equal to the minimum working space and clearance required by NEC.
4. To maintain a safe, clear and level working area in front of new or existing meter and service equipment, a concrete slab or other suitable permanent surface, acceptable to GWP, may be required.
5. For higher voltage installations, consult NEC.

| DATE | REV. | DESCRIPTION | BY | CHK'D | APP. |
|------|------|-------------|----|-------|------|
| | | | | | |



| | | |
|--|---|----------------------------|
| CITY OF GLENDALE WATER & POWER | | |
| REV. NO. DATE 01-14-05 DRAWN BY: BALUYOT APPROVED BY: HRA | WORKING SPACE AND CLEARANCE REQUIREMENTS 0-300 VOLTS | MTR-DWG-007 PAGE 1 of 1 |
| CUSTOMER SERVICE ENGINEERING | | |

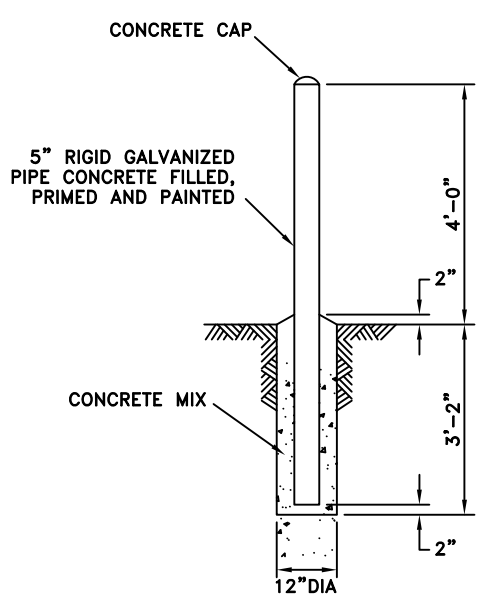
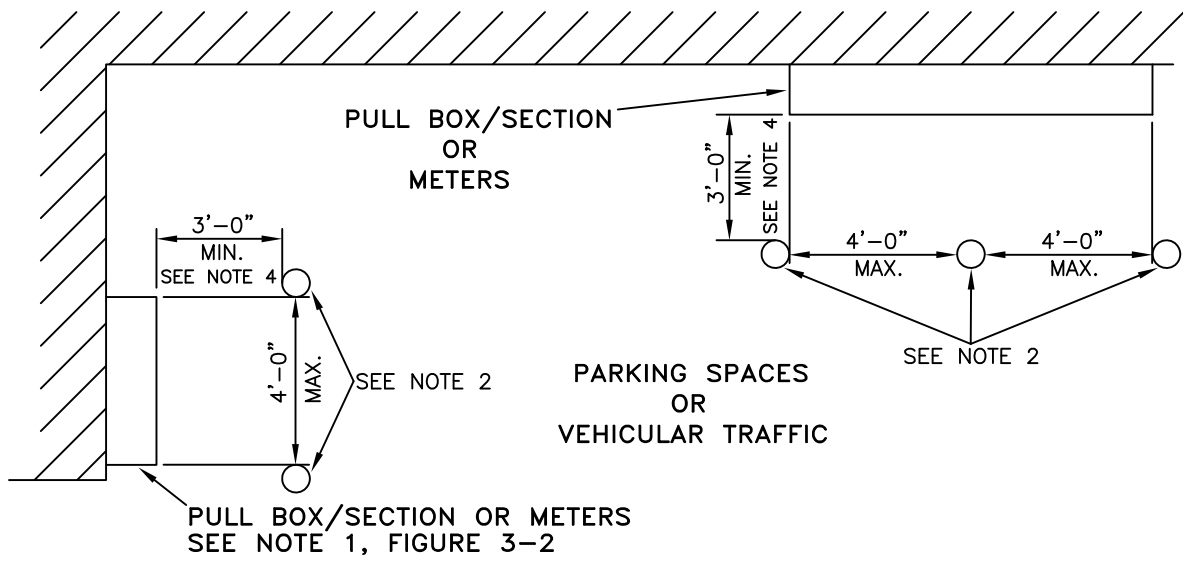

NON-REMOVABLE BARRIER POST DETAIL

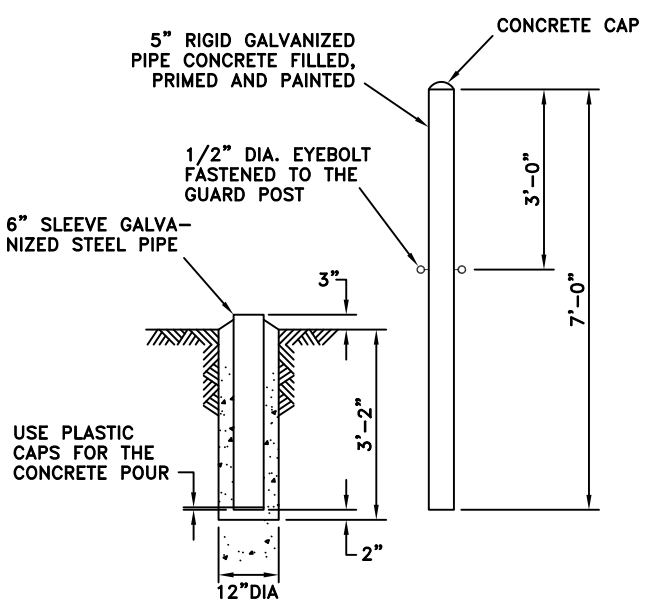

REMOVABLE BARRIER POST DETAIL

NOTES:

1. Meters located on a wall adjacent to any parking area or area accessible to vehicular traffic, including forklifts, shall be protected by non-removable barriers. Wheel stops and removable barriers are not acceptable substitutes. Maintain a minimum of 3 feet of clear and level working space in front of all the service equipment enclosures. Barriers must be so positioned as to allow all service equipment doors/panels to be opened 90 degrees.
2. Barriers must be installed in line with each end of the service equipment to prevent contact. The distance between barriers shall not exceed 4 feet.
3. Before excavating for the barriers, call DIG ALERT 811 for markout service at least 48 hours prior to excavating.
4. For higher voltage installations consult NEC.

| DATE | REV. | DESCRIPTION | BY | CHK'D | APP. |
|------|------|-------------|----|-------|------|
| | | | | | |

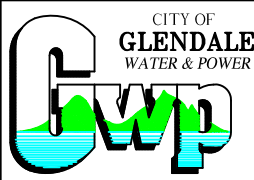

CITY OF GLENDALE WATER & POWER

REV. NO. DATE 01-14-05
 DRAWN BY: BALUYOT
 APPROVED BY: HRA

**PROTECTIVE BARRIER FOR SERVICE EQUIPMENT
 INSTALLATION REQUIREMENTS, 0-300 VOLTS**

MTR-DWG-008
 PAGE 1 of 1

CUSTOMER SERVICE ENGINEERING

FOR DISTRIBUTED GENERATION (SOLAR) DRAWINGS
REFER TO THE NEW REQUIREMENTS SECTION,
DISTRIBUTED ENERGY RESOURCES

| DATE | REV. | DESCRIPTION | BY | CHK'D | APP. |
|---------|------|---|----|-------|------|
| 10/2/18 | 13 | ELIMINATED DG POLICY FROM "METER" SECTION | CC | VMP | DH |

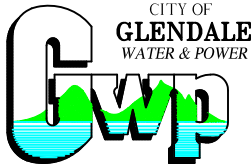

CITY OF
GLENDALE
 WATER & POWER

REV. NO.
 DATE 5/1/09
 DRAWN BY: CC
 APPROVED: HRA

CITY OF GLENDALE WATER AND POWER

SUPERCEDED

MTR-DWG-009
 PAGE 1 of 1

CUSTOMER SERVICE ENGINEERING