

Introduced: 05/14/24, Gharpetian
Adopted: 05/21/24
Gharpetian/Brotman
All Ayes

ORDINANCE NO. 6028

AN ORDINANCE ADOPTING THE 2022 CALIFORNIA BUILDING CODE AS VOLUME IA, THE 2022 CALIFORNIA RESIDENTIAL CODE AS VOLUME IB, THE 2022 CALIFORNIA EXISTING BUILDING CODE AS VOLUME IC, THE 2022 CALIFORNIA PLUMBING CODE AS VOLUME II, THE 2022 CALIFORNIA MECHANICAL CODE AS VOLUME III, THE 2022 CALIFORNIA ELECTRICAL CODE AS VOLUME IV, THE 1997 UNIFORM HOUSING CODE AS VOLUME V, THE 2022 CALIFORNIA FIRE CODE AS VOLUME VI, THE GLENDALE SECURITY CODE AS VOLUME VII AND THE GLENDALE COMMERCIAL, INDUSTRIAL PROPERTY MAINTENANCE CODE AS VOLUME VIII AND THE 2022 CALIFORNIA GREEN BUILDING STANDARDS CODE AS VOLUME IX ALL OF WHICH COMPRISE THE BUILDING AND SAFETY CODE OF THE CITY OF GLENDALE, 2023.

BE IT ORDAINED BY THE COUNCIL OF THE CITY OF GLENDALE:

SECTION INT-1. The City of Glendale hereby adopts a Building and Safety Code of the City of Glendale, 2023, hereinafter designated as the “Glendale Building and Safety Code, 2023.”

SECTION INT-2. Volume IA. Building Standards.

The City of Glendale hereby adopts the 2022 California Building Code as Volume IA of the Glendale Building and Safety Code, 2023. Except as otherwise provided herein, or as later amended, Volume IA of the Glendale Building and Safety Code, 2023, shall be as published in the California Building Code Volumes 1 and 2, 2022 edition, and as copyrighted in 2021 by the International Code Council, Inc. and the California Building Standards Commission, California Code of Regulations, Title 24, Part 2, Volumes 1 and 2, including all of its tables, indices, appendices, addenda and footnotes. Volume IA of the Glendale Building and Safety Code, 2023, shall include the Historic Building Code, 2022 edition, published and copyrighted in 2021 by the California Building Standards Commission, California Code of Regulations, Title 24 Part 8. Said California Building

Code and California Historic Building Code are hereby referred to and by such references are incorporated herein as if fully set forth.

SECTION INT-3. Volume IB. Residential Standards.

The City of Glendale hereby adopts the 2022 California Residential Code as Volume IB of the Glendale Building and Safety Code, 2023. Except as otherwise provided herein, or as later amended, Volume IB of the Glendale Building and Safety Code, 2023, shall be as published in the California Residential Code, 2022 edition, and as copyrighted in 2021 by the International Code Council, Inc. and the California Building Standards Commission, California Code of Regulations, Title 24, Part 2.5, including all of its tables, indices, appendices, addenda and footnotes. Said California Residential Code is hereby referred to and by such reference is incorporated herein as if fully set forth.

SECTION INT-4. Volume IC. Existing Building Standards.

The City of Glendale hereby adopts the 2022 California Existing Building Code as Volume IC of the Glendale Building and Safety Code, 2023. Except as otherwise provided herein, or as later amended, Volume IC of the Glendale Building and Safety Code, 2023, as published and as copyrighted in 2021 by the International Code Council, Inc. and the California Building Standards Commission, California Code of Regulations, Title 24, Part 10, including all of its tables, indices, appendices, addenda and footnotes. Volume IC of the Glendale Building and Safety Code, 2023, shall also include Appendix Chapter A1, A3, A4 and ~~A6~~ A-5 of the California Existing Building Code, 2022 edition, published and copyrighted in 2021 by the International Code Council, Inc. and the California Building Standards Commission, California Code of Regulations, Title 24, Part 10, regarding seismic strengthening provisions for unreinforced masonry bearing

wall buildings. Said California Existing Building Code is hereby referred to and by such references is incorporated herein as if fully set forth.

SECTION INT-5. Volume II. Plumbing Standards.

The City of Glendale hereby adopts the 2022 California Plumbing Code as Volume II of the Glendale Building and Safety Code, 2023. Except as otherwise provided herein, or as later amended, Volume II of the Glendale Building and Safety Code, 2023, shall be as published in the California Plumbing Code 2022 edition, and as copyrighted in 2021 by the International Association of Plumbing and Mechanical Officials and the California Building Standards Commission, California Code of Regulations, Title 24, Part 5, including all of its tables, indices, appendices, addenda and footnotes. Said California Plumbing Code is hereby referred to and by such reference is incorporated herein as if fully set forth.

SECTION INT-6. Volume III. Mechanical Standards.

The City of Glendale hereby adopts the 2022 California Mechanical Code as Volume III of the Glendale Building and Safety Code, 2023. Except as otherwise provided herein, or as later amended, Volume III of the Glendale Building and Safety Code, 2023, shall be as published in the California Mechanical Code, 2022 edition, and as copyrighted in 2021 by the International Association of Plumbing and Mechanical Officials and the California Building Standards Commission, California Code of Regulations, Title 24, Part 4, including all of its tables, indices, appendices, addenda and footnotes. Said California Mechanical Code is hereby referred to and by such reference is incorporated herein as if fully set forth.

SECTION INT-7. Volume IV. Electrical Standards.

The City of Glendale hereby adopts the 2022 California Electrical Code as Volume IV of the Glendale Building and Safety Code, 2023. Except as otherwise provided herein, or as later amended, Volume IV of the Glendale Building and Safety Code, 2023, shall be as published in the California Electrical Code, 2022 edition, and as copyrighted in 2020 to the National Fire Protection Association, Inc. and the California Building Standards Commission, California Code of Regulations, Title 24, Part 3, including all of its tables, indices, appendices, addenda, annexes and footnotes. Said California Electrical Code is hereby referred to and by such reference is incorporated herein as if fully set forth.

SECTION INT-8. Volume V. Housing Standards.

The City of Glendale hereby re-adopts the 1997 Uniform Housing Code as Volume V of the Glendale Building and Safety Code, 2023. Except as otherwise provided herein, or as later amended, Volume V of the Glendale Building and Safety Code, 2023, shall be as published in the Uniform Housing Code, 1997 edition, and as copyrighted in 1997 by the International Conference of Building Officials, including all of its tables, indices, appendices, addenda and footnotes. Said Uniform Housing Code is hereby referred to and by such reference is incorporated herein as if fully set forth.

SECTION INT-9. Volume VI. Fire Safety Standards.

The City of Glendale hereby adopts the 2022 California Fire Code as Volume VI of the Glendale Building and Safety Code, 2023. Except as otherwise provided herein, or as later amended, Volume VI of the Glendale Building and Safety Code, 2023, shall be as published in the California Fire Code, 2022 edition, and as copyrighted in 2021 by the International Code Council, Inc. and the California Building Standards Commission, California Code of Regulations, Title 24, Part 9, including all of its tables, indices, appendices, addenda and footnotes. Said California Fire Code is hereby referred to and by such reference is incorporated herein as if fully set forth.

SECTION INT-10. Volume VII. Security Standards.

Except as otherwise provided herein or as later amended, Volume VII of the Glendale Building and Safety Code, 2023 is hereby re-adopted as the Glendale Security Code, as previously adopted by Ordinance 5937.

SECTION INT-11. Volume VIII. Commercial and Industrial Property Maintenance Standards.

Except as otherwise provided herein or as later amended, Volume VIII of the Glendale Building and Safety Code, 2023 is hereby re-adopted as the Commercial and Industrial Property Maintenance Code, as previously adopted by Ordinance 5937.

SECTION INT-12. Volume IX. Green Building Standards.

The City of Glendale hereby adopts the 2022 California Green Building Standards Code as Volume IX of the Glendale Building and Safety Code, 2023. Except as otherwise provided herein, or as later amended, Volume IX of the Glendale Building and Safety Code, 2023, shall be as published in the California Green Building Standards Code, 2022

edition, and as published in 2021 by the International Code Council, Inc. and the California Building Standards Commission, California Code of Regulations, Title 24, Part 11, including all of its tables, indices, appendices, addenda and footnotes. Said California Green Building Standards Code is hereby referred to and by such reference is incorporated herein as if fully set forth. The voluntary provisions in Appendix Chapter A-4 and Chapter A-5 are not adopted as mandatory compliance features at this time.

SECTION INT-13. Effect of Code on Past Actions and Obligations. The adoption of the Glendale Building and Safety Code, 2023, does not affect any civil lawsuit instituted or filed or prosecutions for ordinance violations committed on or prior to the effective date of said Code, does not waive any fee or penalty due and unpaid prior to the effective date of said Code, and does not affect the validity of any bond or cash deposit posted, filed or deposited pursuant to the requirements of any ordinance.

SECTION INT-14. References to Prior Code. Unless superseded and expressly repealed, references in City forms, documents and regulations to the chapters and sections of the former Glendale Building and Safety Code, 2020, shall be construed to apply to the corresponding provisions contained within the Glendale Building and Safety Code, 2020. Ordinance No. 5937 and No. 5861 of the City of Glendale and all other ordinances or parts of ordinances in conflict herewith are hereby superseded and expressly repealed.

SECTION INT-15. Penalty. Unless otherwise provided in said Code, any person violating any provision of the Glendale Building and Safety Code, 2023, shall be guilty of a misdemeanor and upon conviction thereof, shall be punished by a fine not exceeding one thousand dollars, or by imprisonment in the City jail or the County jail of

the County of Los Angeles for a term not exceeding six months, or both such fine and imprisonment.

SECTION INT-16. Severability. If any provision of this Ordinance or the application thereof to any person or circumstance is held invalid by a court of competent jurisdiction, that invalidity shall not affect other provisions or applications of this Ordinance that can be given effect without the invalid provision of application, and to this end the provisions of this Ordinance are severable.

SECTION INT-17. Effective Date, Exceptions. This ordinance becomes effective and shall be in full force on January 1, 2023; provided, however that where complete plans for buildings have been filed and are pending for building permits prior to the effective date of this Ordinance, permits may be issued, and the applicant may proceed with the construction in strict compliance with former Building and Safety Code, 2017, provided however physical construction is started within one hundred eighty (180) days from the date of issuance of the permit and continued to completion according to said former Building and Safety Code, 2020.

SECTION INT-18. Four-Fifths Vote. The City Clerk shall certify to the passage of this Ordinance by a vote of four-fifths (4/5^{ths}) of the members of the Council of the City of Glendale and shall cause a summary of the same to be published once in the official newspaper of said City.

VOLUME IA. BUILDING STANDARDS

SECTION IA-1. Volume IA of the Glendale Building and Safety Code, 2023, is amended as hereinafter provided.

SECTION IA-2. Chapter 1 Division II Section [A] 101.2 of Volume IA of the Glendale Building and Safety Code, 2023, is hereby amended to read as follows:

[A] 101.2 Scope. The provisions of this code shall apply to the construction, alteration, relocation, enlargement, replacement, repair, equipment, use and occupancy, location, maintenance, removal and demolition of every building or structure or any appurtenances connected or attached to such buildings or structures.

Exception: Detached one-and two-family dwellings and multiple single-family dwellings (townhouses) not more than three stories above grade plane in height with a separate means of egress, and their accessory structures not more than three stories above grade plane in height, shall comply *with this code or the California Residential Code* as adopted and amended as Volume IB of the Glendale Building and Safety Code.

[A] 101.2.1 Appendices. Provisions in the appendices shall not apply unless specifically adopted.

SECTION IA-3. Chapter 1 Division II Section 104.10.2 of Volume IA of the Glendale Building and Safety Code, 2023, is hereby added to read as follows:

104.10.2 Fire code official concurrence. For those cases which may affect fire or life safety in buildings regulated by the State Fire Marshall, the building official shall obtain the concurrence of the fire code official if related to fire protection systems, egress, fire department access or water supply.

SECTION IA-4. Chapter 1 Division II Section 104.11.5 of Volume IA of the Glendale Building and Safety Code, 2023, is hereby added to read as follows:

104.11.5 Fire code official concurrence. For those cases which may affect fire or life safety in buildings regulated by the State Fire Marshall, the building official shall obtain the concurrence of the fire code official if related to fire protection systems, egress, fire department access or water supply.

SECTION IA-5. Chapter 1 Division II Section [A] 105.1 of Volume IA of the Glendale Building and Safety Code, 2023, is hereby amended to read as follows:

[A] 105.1 Required. Any owner or owner's authorized agent who intends to construct, enlarge, alter, repair, move, demolish, or change the occupancy of a building or structure, or to erect, install, enlarge, alter, repair, remove, convert, or replace any electrical, gas, mechanical or plumbing system, the installation of which is regulated by this code, or to cause any such work to be performed, shall first make application to the building official and obtain the required permit. Parking lots shall not be paved, improved, striped, or restriped unless a separate permit for each parking lot has first been obtained from the building official.

Exception: A separate permit shall not be required to pave, improve, stripe, or restripe a parking lot when such work is included in the scope of another project for which a building permit has been issued and when the design of such parking lot was included in the plan check review of such project.

SECTION IA-6. Chapter 1 Division II Section [A] 105.3 of Volume IA of the Glendale Building and Safety Code, 2023, is hereby amended to read to read as follows:

[A] 105.3 Application for permit. To obtain a permit, the applicant shall first file an application therefor in writing on a form furnished by the department of building safety

for that purpose. such application shall:

1. Identify and describe the work to be covered by the permit for which application is made.
2. Describe the land on which the proposed work is to be done by legal description, street address or similar description that will readily identify and definitely locate the proposed building or work.
3. Indicate the use and occupancy for which the proposed work is intended.
4. Be accompanied by construction documents and other information as required in Section 107.
5. State the valuation of the proposed work.
6. Be signed by the applicant, or the applicant's authorized agent.
7. Give such other data and information as required by the building official.
8. Pay plan review and permit fees as required by this Chapter 1 Division II.

SECTION IA-7. Chapter 1 Division II Section 105.3.1.1 of Volume IA of the Glendale Building and Safety Code, 2020, is hereby added to read as follows:

105.3.1.1 Electric vehicle charging station review process.

105.3.1.1.1 Purpose. The purpose of this Section is to promote and encourage the use of electric vehicles by creating an expedited, streamlined permitting process for electric vehicle charging stations while promoting public health and safety and preventing specific adverse impacts in the installation and use of such charging stations. This Section is also purposed to comply with California Government Code Section 65850.7.

105.3.1.1.2 Definitions.

- (a) **“Electric vehicle charging station” or “charging station”** means any level of electric vehicle supply equipment station that is designed and built in compliance

with Article 625 of the California Electrical Code, as it reads on the effective date of this Section, and delivers electricity from a source outside an electric vehicle into a plug-in electric vehicle.

- (b) **“Electric vehicle charging space”** means a space intended for charging electric vehicles.
- (c) **“Specific, adverse impact”** means a significant, quantifiable, direct, and unavoidable impact, based on objective, identified, and written public health or safety standards, policies, or conditions as they existed on the date the application was deemed complete.
- (d) **“Electronic submittal”** means the utilization of one or more of the following:
 - a. Electronic mail or email.
 - b. The internet.
 - c. Facsimile.

105.3.1.1.3. Expedited permitting process. Consistent with Government Code Section 65850.7, the Building Official shall implement an expedited, streamlined permitting process for electric vehicle charging stations and electrical vehicle charging spaces, and adopt a checklist of all requirements with which electric vehicle charging stations and electrical charging spaces shall comply with in order to be eligible for expedited review. The expedited, streamlined permitting process and checklist may refer to the recommendations contained in the most current version of the “Plug-In Electric Vehicle Infrastructure Permitting Checklist” of the “Zero-Emission Vehicles in California: Community Readiness Guidebook” as published by the Governor’s Office of Planning and Research. The City’s adopted checklist shall be published on the City’s website.

105.3.1.1.4 Permit application processing.

- (a) Prior to submitting an application for processing, the applicant shall verify that the installation of an electric vehicle charging station and electric vehicle charging space will not have specific, adverse impact to public health and safety and building occupants. Verification by the applicant includes but is not limited to: electrical system capacity and loads; electrical system wiring, bonding and overcurrent protection; building infrastructure affected by charging station equipment and associated conduits; areas of charging station equipment and vehicle parking.
- (b) A permit application that satisfies the information requirements in the City's adopted checklist shall be deemed complete and be promptly processed. Upon confirmation by the Building Official that the permit application and supporting documents meets the requirements of the City adopted checklist, and is consistent with all applicable laws and health and safety standards, the Building Official shall, consistent with Government Code Section 65850.7, approve the application and issue all necessary permits. Such approval does not authorize an applicant to energize or utilize the electric vehicle charging station until approval is granted by the City. If the Building Official determines that the permit application is incomplete, he or she shall issue a written correction notice to the applicant, detailing all deficiencies in the application and any additional information required to be eligible for expedited permit issuance.
- (c) Consistent with Government Code Section 65850.7, the Building Official shall allow for electronic submittal of permit applications covered by this Ordinance and associated supporting documentations. In accepting such permit applications, the

Building Official shall also accept electronic signatures on all forms, applications, and other documentation in lieu of a wet signature by any applicant.

105.3.1.1.5. Technical Review.

- (a) It is the intent of this Section to encourage the installation of electric vehicle charging stations and electric vehicle charging spaces by removing obstacles to permitting for charging stations and charging spaces so long as the action does not supersede the Building Official's authority to address higher priority life-safety situations. If the Building Official makes a finding based on substantial evidence that the electric vehicle charging station and electric vehicle charging space could have a specific adverse impact upon the public health or safety, as defined in this Chapter, the City may require the applicant to apply for a use permit.
- (b) In the technical review of a charging station and charging space, consistent with Government Code Section 65850.7, the Building Official shall not condition the approval for any electric vehicle charging station and electric vehicle charging space permit on the approval of such a system by an association, as that term is defined by Civil Code Section 4080.

105.3.1.1.6. Electric vehicle charging space installation requirements.

- (a) Electric vehicle charging station equipment shall meet the requirements of the California Electrical Code, the Society of Automotive Engineers, the National Electrical Manufacturers Association, and accredited testing laboratories such as Underwriters Laboratories, and rules of the Public Utilities Commission or a Municipal Electric Utility Company regarding safety and reliability.

- (b) Installation of electric vehicle charging stations shall be incorporated into the load calculations of all new or existing electrical services and shall meet the requirements of the California Electrical Code. Electric vehicle charging equipment shall be considered a continuous load.
- (c) Anchorage of either floor-mounted or wall-mounted electric vehicle charging stations shall meet the requirements of the California Building or Residential Code as applicable per occupancy, and the provisions of the manufacturer's installation instructions. Mounting of charging stations shall not adversely affect building elements.
- (d) Electric vehicle charging space shall comply with the provisions in Chapter 11A or Chapter 11B of the California Building Code.

SECTION IA-8. Chapter 1 Division II Section [A] 105.3.2 of Volume IA of the Glendale Building and Safety Code, 2023 is hereby amended to read as follows:

[A] 105.3.2 Time limitation of application. An application for a permit for any proposed work shall be deemed to have been abandoned one-year after the date of filing, unless such application has been pursued in good faith or a permit has been issued; except that the building official is authorized to grant one or more extensions of time for additional periods not exceeding 180 days. The extension shall be requested in writing and justifiable cause demonstrated. *[OSHPD 1, 1R, 2, 4 & 5] Time limitation shall be in accordance with the California Administrative Code, Chapter 7, Section 7-129.*

SECTION IA-9. Chapter 1 Division II Section 105.3.3 of Volume IA of the Glendale Building and Safety Code, 2023, is hereby added to read as follows:

105.3.3 Plan review fees. When submittal documents are required by Chapter 1 Division II,

Section 105.3, a plan review fee shall be paid at the time of submitting the submittal documents for plan review. The plan review fees specified in this section are separate fees from the permit fees specified in Chapter 1 Division, Section [A] 109.2 and are in addition to the permit fees. When submittal documents are incomplete or changed so as to require additional plan review, or when the project involves deferred submittal items as defined in Chapter 1 Division II, Section [A] 107.3.4.1, an additional plan review fee shall be charged at a rate specified by resolution. In granting any extension the building official may require compliance with any new regulation. In order to renew action on an application after expiration, the applicant shall resubmit plans and pay a new plan review fee. The new plan review fee shall be one half the amount required for a new plan review, provided no changes have been made in the original plans and specifications for such work, and provided further that such abandonment has not exceeded one year. In order to renew action on an expired application the applicant shall comply with all applicable new regulations.

SECTION IA-10. Chapter 1 Division II Section [A] 105.5 of Volume IA of the Glendale Building and Safety Code, 2023, is hereby amended to read as follows:

[A] 105.5 Expiration. Every permit issued shall become invalid unless the work on the site authorized by such permit is commenced within 180 days after its issuance, or if the work authorized on the site by such permit is suspended or abandoned for a period of 180 days after the time the work is commenced. Work shall be considered suspended or abandoned if the building official determines that substantial work has not been performed within the time specified above. Substantial work shall be construed to mean:

1. Measurable work such as, but not limited to, the addition of footings, structural members, flooring, wall covering, etc.

2. The work mentioned in subsection 1 of this Section [A] 105.5 above must constitute 20% of the value of the work for which the permit was issued in any 180 day period for Group R, Division 3 occupancies and 10% for all other occupancies.

Before such work can be recommenced, a new permit shall be first obtained to do so, and the fee therefore shall be one half the amount required for a new permit for such work, provided no changes have been made or will be made in the original plans and specifications for such work, and provided further that such suspension or abandonment has not exceeded one year. In order to renew action on a permit after expiration, the permittee shall pay a new permit fee and may be required to comply with all applicable new regulations at the time of issuance. The building official is authorized to grant, in writing, one or more extensions of time, for periods not more than 180 days each. The extension shall be requested in writing and justifiable cause demonstrated.

SECTION IA-11. Chapter 1 Division II Section 105.8 of Volume IA of the Glendale Building and Safety Code, 2023, is hereby added to read as follows:

105.8 Responsibility of permittee. Building permits shall be presumed by the city to incorporate all of the work that the applicant, the applicant's agent, employees and/or contractors shall carry out. Said proposed work shall be in accordance with the approved plans and with all requirements of this code and any other laws or regulations applicable thereto. No city approval shall relieve or exonerate any person from the responsibility of complying with the provisions of this code nor shall any vested rights be created for any work performed in violation of this code.

SECTION IA-12. Chapter 1 Division II Section [A] 107.3.4 of Volume IA of the Glendale Building and Safety Code, 2023, is hereby amended to read as follows:

[A] 107.3.4 Design professional in responsible charge.

It shall be required that all documents submitted for review by the building official shall be prepared by a registered design professional. The building official shall be authorized to require the owner or the owner's authorized agent to engage and designate on the building permit application a registered design professional who shall act as the registered design professional in responsible charge. If the circumstances require, the owner or the owner's authorized agent shall designate a substitute registered design professional in responsible charge who shall perform the duties required of the original registered design professional in responsible charge. The building official shall be notified in writing by the owner or the owner's authorized agent if the registered design professional in responsible charge is changed or is unable to continue to perform the duties.

The registered design professional in responsible charge shall be responsible for reviewing and coordinating submittal documents prepared by others, including phased and deferred submittal items, for compatibility with the design of the building.

Exception: The building official may waive the requirements for a registered design professional when, after reviewing the submitted plans it is determined that the work is minor in nature.

SECTION IA-13. Chapter 1 Division II Section [A] 109.4 of Volume IA of the Glendale Building and Safety Code, 2023, is hereby amended to read as follows:

[A] 109.4 Work commencing before permit issuance. Any person who commences any work on a building, structure, electrical, gas, mechanical or plumbing system before obtaining the necessary permits shall be subject to a fee in addition to the normally established permit fee, equal to 100% of such normally established permit fee, or as otherwise determined by the building official.

SECTION IA-14. Chapter 1 Division II Section [A] 110.3.5 of Volume IA of the Glendale Building and Safety Code, 2023, is hereby amended to read as follows:

[A] 110.3.5 Lath, gypsum board and gypsum panel product inspection. Lath, gypsum board and gypsum panel product inspections shall be made after lathing, gypsum board and gypsum panel products, interior and exterior, are in place, but before any plastering is applied or gypsum board and gypsum panel products joints and fasteners are taped and finished.

Exception: Gypsum board and gypsum panel products that are not part of a fire-resistance-rated assembly, a shear assembly or a sound transmission control assembly.

SECTION IA-15. Chapter 1 Division II Section 110.3.9.1 of Volume IA of the Glendale Building and Safety Code, 2023, is hereby added to read as follows:

110.3.9.1 Structural observation. For structural observation, see Section 1704 of Volume IA of the Glendale Building and Safety Code, 2023.

SECTION IA-16. Chapter 1 Division II Section 110.7 of Volume IA of the Glendale Building and Safety Code, 2023, is hereby added to read as follows:

110.7 Re-inspections. A re-inspection fee may be assessed for each inspection or re-inspection when such portion of work for which inspection is called is not complete or when corrections called for are not made.

This section shall not be interpreted as requiring re-inspection fees the first time a job is rejected for failure to comply with the requirements of this code, but as controlling the practice of calling for inspections before the job is ready for such inspection or re-inspection.

Re-inspection fees may be assessed when the approved plans and inspection card are not readily available to the inspector, for failure to provide access on the date for which inspection is requested, or deviation from plans requiring the approval of the Building Official.

To obtain a re-inspection, the applicant shall pay the re-inspection fee in accordance with a fee schedule adopted by this jurisdiction.

In instances where re-inspection fees have been assessed, no additional inspection of the work will be performed until the required fees have been paid.

SECTION IA-17. Chapter 1 Division II Section 113 of Volume IA of the Glendale Building and Safety Code, 2023, is hereby amended to read as follows:

SECTION 113

BUILDING AND FIRE BOARD OF APPEALS

[A] 113.1 General. In order to hear and decide appeals of orders, decisions or determinations made by the building official or the fire code official relative to the application and interpretation of all volumes of this code, there shall be and is hereby created a joint building and fire board of appeals. The board appointment and composition shall be in accordance with the governing body. The building official or the fire code official shall be an ex-officio member of said board but shall have no vote on any matter before the board. The building official shall act as the secretary to said board. The board shall adopt rules of procedure for conducting its business, and shall render all decisions and findings in writing to the appellant with a duplicate copy to the building official and fire code official.

[A] 113.2 Limitations on authority. The building and fire board of appeals shall have no authority relative to interpretation of the administrative provisions of this code nor shall the board be empowered to waive requirements of this code.

[A] 113.3 Qualifications. The board of appeals shall consist of members who are qualified pursuant to Section 2.56.040 of the Glendale Municipal Code, 1995.

113.4 Procedure for Appeals to the Building and Fire Board of Appeals.

113.4.1 Fee. A non-refundable fee for an appeal shall be established or modified by resolution of the City Council. The building official, fire code official, or both shall review said fee no more than once annually and may, with approval of the City Manager, recommend changes to the City Council.

113.4.2 Application. With the advice of the building official and fire code official, the Building and Fire Board of Appeals shall approve the form of application for appeals. Such application shall include but not be limited to the following items: address and description of the property involved; statement of all facts upon which the applicant relies; any plans, sketches, or reports to support the applicant's case or as may be required by the board; the specific section or decision relevant to the applicant's appeal; a detailed account to the appellant's position and justification showing how his or her position meets or exceeds Code.

113.4.3 Acceptance and application. Upon filing of a complete application and payment of the fee, the application shall be reviewed by the building official or fire code official, or both, for completeness and conformance with this Code and the board's adopted policies and procedures. Applications which are found to be complete and compliant shall be accepted and submitted for the board's consideration.

113.4.4 Public hearing. Upon acceptance of an application, the building official shall set the matter for public hearing and notice shall be given as required by the policies and procedures of the board. The essential facts found at such hearing shall be recorded in the minutes of the board. A copy of the findings and decision of the board shall be

mailed to the applicant at the address given in the application, with duplicate copies to the building official and the fire code official.

113.4.5 Appeal to City Council. Any person, including any city official, aggrieved by the decision of the building and fire board of appeals, may appeal to the City Council with the time and in the manner provided in chapter 2.88 of the Glendale Municipal Code, 1995.

SECTION IA-18. Chapter 1 Division II Section [A] 114.1 of Volume IA of the Glendale Building and Safety Code, 2023, is hereby amended to read as follows:

[A] 114.1 Unlawful acts. It shall be unlawful for any person, firm or corporation to erect, construct, alter, extend, repair, move, remove, demolish, occupy, or maintain any building, structure or equipment regulated by this code, or cause same to be done, in conflict with or in violation of any of the provisions of this code. Maintenance of a building or structure which was unlawful at the time it was constructed and which would be unlawful under this Code if constructed after the effective date of such Code, shall constitute a continuing violation of such Code.

SECTION IA-19. Chapter 1 Division II Section [A] 114.4 of Volume IA of the Glendale Building and Safety Code, 2023, is hereby amended to read as follows:

[A] 114.4 Violation penalties. Any person who violates a provision of this code or fails to comply with any of the requirements thereof or who erects, constructs, alters or repairs a building or structure in violation of the approved construction documents or directive of the building official, or of a permit or certificate issued under the provisions of this code, shall be deemed guilty of a misdemeanor and shall be punishable by a fine of not more than \$1,000.00 or by imprisonment for a term of not more than 6 months, or by both such fine and imprisonment. Such penalty and

imprisonment shall not preclude the imposition of any other administrative or judicial civil or criminal remedies under state, federal or local laws.

SECTION IA-20. Chapter 1 Division II Section [A] 115.1 of Volume IA of the Glendale Building and Safety Code, 2023, is hereby amended to read as follows:

[A] 115.1 Authority. Whenever the building official finds any work regulated by this code being performed in a manner either contrary to the provisions of this code or other laws or ordinances of this jurisdiction or dangerous or unsafe, the building official is authorized to issue a stop work order.

SECTION IA-21. Chapter 1 Division II Section [A] 115.3 of Volume IA of the Glendale Building and Safety Code, 2023, is hereby amended to read as follows:

[A] 115.3 Unlawful continuance. Any person who shall continue any work after having been served with a stop work order, except such work as that person is directed to perform to remove a violation or unsafe condition, shall be guilty of a misdemeanor.

SECTION IA-22. Chapter 1 Division II Section 116.6 of Volume IA of the Glendale Building and Safety Code, 2023, is hereby added to read as follows:

116.6 Non-Compliance. Upon failure to comply with the order within the time specified herein, and if no appeal has been properly and timely filed, the building official shall file in the office of the County Recorder a certificate describing the property and certifying (i) that the building is an unsafe building and (ii) that the owner has been notified. Whenever the corrections ordered shall thereafter have been completed or the building demolished so that it no longer exists as an unsafe building on the property described in the certificate, the building official shall file a new certificate with the County Recorder certifying that the building has been demolished or all

required corrections have been made so that the building is no longer unsafe, whichever is appropriate.

SECTION IA-23. Chapter 1 Division II Section 116.7 of Volume IA of the Glendale Building and Safety Code, 2023, is hereby added to read as follows:

116.7 Vacated Buildings. Any unsafe building ordered vacated in accordance with this section shall not be reoccupied until the unsafe conditions have been eliminated. Each such vacated building shall be locked and otherwise secured against entry and the building official shall post thereon a placard stating: “DO NOT ENTER, UNSAFE TO OCCUPY, CITY OF GLENDALE.” Such notice shall remain posted until the required repairs, demolition or removal are completed. Such notice shall not be removed without written permission of the building official and no person shall enter the building except for the purpose of making the required repairs or of demolishing the building.

SECTION IA-24. Chapter 1 Division II Section 118 of Volume IA of the Glendale Building and Safety Code, 2023, is hereby added to read as follows:

SECTION 118

CONSTRUCTION TOILET FACILITIES

118 Temporary Construction Toilets. Toilet Facilities Required. No person shall commence or proceed with the erection, construction, alteration, repair, raising, adding to, removal, or demolition of any building or structure unless adequate, suitable, sanitary toilet facilities under the control of such person are provided for the use of any person employed or working upon such building or structure. Such toilet facilities shall be located upon or within a reasonable distance of the lot, premises, or site upon which such work is being done.

In no case shall the line of travel to any facility exceed five hundred feet (500') (153 M). Toilets may not be placed on the public way.

118.1 Toilet Standards. Every toilet shall be of water flush type and shall be connected to a public sewer or private sewage disposal system built in accordance with the provisions of the Plumbing Code. All toilet structures shall be self-closing; the toilet floor shall be smooth, and screened ventilation shall be provided for the toilet compartment. Where workmen are employed during night hours, the toilet building shall be provided with artificial light. In lieu of flush water closets approved chemical toilets may be provided. Toilets may not be located within 10' (3054 mm) of a property line.

SECTION IA-25. Chapter I Division II Section 119 of Volume IA of the Glendale Building and Safety Code, 2023, is hereby added to read as follows:

SECTION 119

ON SITE CONSTRUCTION TRASH AND DEBRIS CONTROL

119 On Site Construction Trash and Debris Control Facilities Required.

No person shall commence or proceed with erection, construction, alteration, repair, raising, adding to, removal, or demolition of any building or structure unless adequate, suitable on site trash and debris control facilities under the control of such person are provided for the use of any person employed or working upon such building or structure. On site trash and debris control shall consist of at least a roll off 523 ft³ (15m³) bin. The container shall be emptied often enough so that no storage of trash is outside the bin. The bin shall be removed from the site after the building has passed final inspection or within thirty (30) days of the expiration of the building permit.

Exception: Additions, less than 900 ft² (84m²), and alterations to Group R, Division 3 occupancies and Group U occupancies need not provide a roll off bin but must store trash and debris in the rear yard in quantities less than 10 ft (3m) wide by 10 ft (3m) long by 4 ft (1.2m) high. All trash and debris whether or not in containers shall be kept 3 ft (912mm) from adjacent property lines.

SECTION IA-26. Chapter 1 Division II Section 120 of Volume IA of the Glendale Building and Safety Code, 2023, is hereby added to read as follows:

SECTION 120

DISASTER REPAIR AND RECONSTRUCTION

120.1 Intent. This section establishes standards and regulations for the expeditious repair and reconstruction of structures damaged as a result of a disaster for which a local emergency has been declared by the City Council. This section does not allow exemptions from the Building, Fire, Electrical, Mechanical, Plumbing, other Codes, or standards.

120.2 Applications of Provisions.

120.2.1 The provisions of this section are applicable following each disaster when a local emergency has been declared by the City Council to all buildings and structures of all occupancies regulated by the City of Glendale. The Council may extend the provisions as necessary.

120.2.2 When approved by the building official, the requirements of this section may be waived in favor of repair recommendations included in an engineering evaluation as defined in Section 120.3.

120.3 Definitions. For the purpose of this section 120, the following definitions apply:

120.3.1 “Architect” means an individual licensed by the State of California to practice architecture as defined in the State of California Business and Professions Code.

120.3.2 “Civil Engineer” means an individual registered by the State of California to practice civil engineering as defined in the State of California Business and Professions Code.

120.3.3 “Current Code” means the edition of the California Building Code, published by the International Code Council, as adopted by the City of Glendale as the Glendale Building and Safety Code, as amended. The edition of said Glendale Building and Safety Code to be applied shall be that edition in effect at the time of the declaration of a local emergency by the City Council.

120.3.4 “Engineering Evaluation” means an evaluation of a damaged building or structure, or suspected damaged building or structure, performed under the direction of a structural engineer, civil engineer, or architect retained by the owner of the building or structure. Engineering evaluations shall, at a minimum, contain recommendations for repair with appropriate opinion of construction cost for those repairs.

120.3.5 “Replacement Value” means the dollar value, as determined by the new building official, of replacing the damaged structure with a new structure of the same size, construction material and occupancy on the same site.

120.3.6 “Structural Engineer” means an individual registered by the State of California to practice structural engineering and to use the title structural engineer as defined in the State of California Business and Professions Code.

120.3.7 “Value of Repair” means the dollar value, as determined by the building official, of making the necessary repairs to the damaged building.

120.4 Repair Criteria.

120.4.1 Abatement of Dangerous Buildings shall be in accordance with the provisions of Chapter 1 Division II, Section 116.

120.4.2 Building and structures of all occupancies which have been damaged as a result of a disaster, except as otherwise noted, shall be repaired in accordance with the following criteria:

1. When the estimated value of repair does not exceed ten percent (10%) of the replacement value of the structure, the damaged portion(s) may be restored to their pre-disaster condition.

Exception: When the damaged elements include suspended ceiling systems, the ceiling system shall be repaired and all bracing required by current code shall be installed.

2. When the estimated value of repair is greater than ten percent (10%) but less than fifty percent (50%) of the replacement value of the structure, the damaged elements, as well as all critical ties, supported elements and supporting elements associated with the damaged elements, shall be repaired and/or brought into conformance with the structural requirements of the current Code.
3. When the estimated value of repair is fifty percent (50%) or more of the replacement value of the structure, the entire structure shall be brought into conformance with the structural requirements of the current Code.
4. In Group R, Division 3 occupancies, the repair value of damaged chimneys shall be excluded from the computation of percentage of replacement value. Damaged chimneys shall be repaired in accordance with Chapter 1 Division II, Section

120.5.

120.5 Repair Criteria for Chimneys.

120.5.1 All damaged chimneys must be repaired or reconstructed to comply with the requirements of Section 2113 of the Glendale Building and Safety Code, 2023. Damaged portions of chimneys shall be removed in accordance with the following criteria:

1. When the damaged portion of the chimney is located between the roof line and the top of the chimney, the damaged portion shall be removed to the roof line provided the roof and ceiling anchorage are in sound condition.
2. For a single-story structure in which the damaged portion of the chimney is below the roof line or the damaged portion extends from above the roof line to below the roof line, the chimney shall be removed to the top of the fire box.
3. For a multi-story structure, the damaged portion of the chimney shall be removed from the top to a floor line where sound anchorage is found.
4. In any structure where the firebox has been damaged, the entire chimney and firebox shall be removed to the foundation. If this foundation is in sound condition, the firebox and chimney may be reconstructed using the existing foundation. If the foundation has been damaged, the foundation shall be removed and replaced.

120.5.2 Where existing conditions preclude the installation of all anchorage required by Section 2113 of the current Code, alternate systems may be used in accordance with the alternate methods and materials provisions of the current Code when approved by the building official. Such alternate systems shall be designed and detailed by a structural engineer, civil engineer, or architect.

120.6 Repair Criteria for Unreinforced Masonry Buildings and Structures.

120.6.1 All buildings as described in Appendix Chapter A1, Section A102.1 of the California Existing Building Code of Volume IC of the Glendale Building and Safety Code that are damaged shall be repaired and strengthened in accordance with provisions of Chapter 1 Division II, Section 120.4.

120.6.2 Unreinforced masonry buildings damaged less than 50% shall be repaired in accordance with California Existing Building Code, Appendix Chapter A1, Seismic Strengthening Provisions for Unreinforced Masonry Bearing Wall Buildings of Volume IC of this Code.

SECTION IA-27. Chapter 1 Division II Section 121 of Volume IA of the Glendale Building and Safety Code, 2023, is hereby added to read as follows:

SECTION 121

SANDBLASTING

121.1. Sandblasting: Definition. As used in this article, unless the context expressly indicates otherwise, "sandblasting" shall mean the use of air, steam or water containing sand to clean, grind, or cut hard surfaces.

121.2. Dry Sandblasting. Dry sandblasting is prohibited unless authorized by special permission from the building official endorsed upon a permit. Permission for dry sandblasting may be granted only when it is not possible to employ wet sandblasting. When dry sandblasting is permitted, the building official may impose such reasonable and related conditions as he or she may deem necessary for the protection of the public and the adjacent property.

121.3. Use of Canvas. Sandblasting operations shall, at all times, be separated from all adjacent property by canvas or other suitable barrier to prevent the splashing or blowing of water and/or sand thereupon.

121.4. Stoppage of Work. The building official may order the immediate stoppage of sandblasting for failure to comply with any provision of this chapter. Failure of any person to comply immediately with such order shall constitute a misdemeanor.

SECTION IA-28. Section 202 of Volume IA of the Glendale Building and Safety Code, 2023, is hereby amended to read as follows:

202 Definitions. For the purposes of this section certain term is defined as follows:

INTERMODAL SHIPPING CONTAINER. A six-sided steel unit originally constructed as a general cargo container used for the transport of goods and materials.

SECTION IA-29. Section [F] 403.3 of Volume IA of the Glendale Building and Safety Code, 2023, is hereby amended to read as follows:

[F] 403.3 Combination automatic sprinkler/standpipe system. Buildings and structures shall be equipped throughout with a combination automatic sprinkler/ standpipe system in accordance with Section 903.3.1.1 and a secondary water supply in accordance with Section 403.3.3, and the policies of the fire code official. Standpipes shall provide for a looped redundant sprinkler supply at each floor level. *A sprinkler water-flow alarm-initiating device and a control valve with a supervisory signal-initiating device shall be provided at each of the lateral connections to the risers on each floor.*

SECTION IA-30. Section 403.3.3 of Volume IA of the Glendale Building and Safety Code, 2023, is hereby amended to read as follows:

[F] 403.3.3 Secondary water supply. An automatic secondary on-site water supply having a *usable* capacity not less than the hydraulically calculated sprinkler demand, including the hose stream requirement for a duration of not less than 30 minutes, or the fire pump's listed flow at 100% for a duration of not less than 30 minutes, whichever is greater, shall be provided for high-rise buildings *and Group I-2 occupancies having occupied floors located more than 75 feet above the lowest level of fire department vehicle access* in Seismic Design Category C, D, E or F as determined by the *California Building Code*. *The Class I standpipe system demand shall not be required to be included in the secondary on-site water supply calculations. In no case shall the secondary on-site water supply be less than 15,000 gallons.*

Exception: Existing buildings.

SECTION IA-31. Section 503.2 of Volume 1A of the Glendale Building and Safety Code, 2023, is hereby added to read as follows:

503.2 Construction on contiguous lots under same ownership or occupancy. In those cases where lots, or portions of lots, contiguous to one another are owned or occupied by the same person, such lots, or portions of lots, may be considered one lot for the purpose of enforcing Sections 503, 602.1, Table 602, Table 504.4 and Table 506.2 of this Code. In such event, the owner of said lots shall be required to execute and record a covenant and agreement with the City to the satisfaction of the building official on a form approved by the City Attorney. Said covenant and agreement shall, among other things, provide that said lots or portions of lots shall remain as one parcel and the owner thereof shall not sell, transfer or in any way sever any portion of said lots or portions of lots independently from the remaining lots or portions of lots until or unless released from the covenant and agreement by the city. Said covenant and agreement shall be recorded by the Los Angeles County Recorder, shall run with the lot or

portions of lots, and shall be binding upon the owner, future owners, encumbrancers, successors, heirs, and assigns. An easement or dedication for public right of way purposes shall not constitute ownership or occupancy under this Section 503.2. The building official is hereby authorized to execute such covenants and agreements on behalf of the City.

SECTION IA-32. Section [F] 903.2.21 of Volume IA of the Glendale Building and Safety Code, 2023, regarding where automatic sprinkler systems are required, is hereby added to read as follows:

[F] 903.2.21 Where required. Notwithstanding other provisions of the code, *approved automatic sprinkler systems* in new and existing buildings and structures shall be provided in accordance with this section.

Exceptions:

1. When approved by the fire code official, spaces or areas in telecommunications buildings used exclusively for telecommunication equipment, associated electrical power distribution equipment, batteries and standby engines, provided those spaces or areas are equipped throughout with an automatic fire alarm system and are separated from the remainder of the building by fire barriers consisting of not less than one-hour fire-resistance-rated walls and two-hour fire-resistance-rated floor/ceiling assemblies.
2. *Automatic fire sprinkler protection for fixed guideway transit systems shall comply with Section 903.2.20.17.*

903.2.21.1 New occupancies. An automatic sprinkler system shall be installed in all new occupancies.

Exceptions:

1. Group B, Group F Divisions 1 and 2, and Group M occupancies, less than 1000 total square feet (92.9 m²).
2. Group S Division 1 occupancies not classified as motor vehicle repair garages less than 1000 total square feet (92.9 m²).
3. Group S Division 2 occupancies not classified as parking garages less than 1000 total square feet (92.9 m²).

903.2.21.2 Existing occupancies. An automatic sprinkler system shall be installed and maintained in all existing occupancies as follows:

1. Throughout existing and new sections of any existing building whenever total additions result in an increase of more than 1000 square feet (92.9 m²) in the total floor area, including mezzanines or additional stories, regardless of ownership. Additions shall be cumulative with each application for building permit within the previous five years.

Exception: Group R, Division 3 occupancies.

2. Throughout existing and new sections of any existing building whenever alterations exceed fifty percent (50%) of the replacement value, as determined by the building official. Alteration values shall be cumulative with each application for a building permit within the previous five years.

Exception: Expenditures for tenant improvements, maintenance and repairs such as interior and exterior painting, carpeting, interior window coverings, drapes, movable partitions, surface re-roofing or plumbing, mechanical and electrical repairs.

3. Throughout existing and new sections of any existing building for which there is an occupancy classification change to a more hazardous use, as determined by the fire code official or building official.

4. Throughout any existing Group R Division 2 occupancy being subdivided to condominium units.
5. Existing high-rise buildings. "Existing high-rise buildings," as defined in Volume I shall have an automatic sprinkler system installed and operational throughout.
6. Existing mid-rise buildings. Existing mid-rise buildings shall have an automatic fire sprinkler system installed and operational throughout. For the purpose of this section, "mid-rise building" means any building six or more stories in height or more than 55 feet (16,764 mm) in height and not defined as a high-rise building. Measurement shall be from the underside of the roof or floor above the topmost occupiable space to the lowest fire apparatus access road level or building access, whichever is lower.

Exception: Open parking garages.

7. Existing low-rise building. Existing low-rise buildings shall have an automatic fire sprinkler system installed and operational throughout. For the purpose of this section, "low-rise building" means any building four or more stories in height but less than 55 feet (16,764 mm) in height from the lowest level of Fire Department access. Measurement shall be from the underside of the roof or floor above the topmost occupiable space to the lowest fire apparatus access road level or building access, whichever is lower.

Exception: Open parking garages.

903.2.21.2.1 Notification, recordation, enforcement, and standards.

Notification, recordation, enforcement and standards addressed in this Section 903.2.20.2.1 shall be enforced by the fire code official to ensure compliance with Section 903.2.20.2, subsections 6, 7, and 8.

1. Notification. Whenever, pursuant to Section 903.2.20.2, the fire code official determines by inspection that a building does not conform to the minimum requirements of Section 903.2.20.2, subsection 6, 7 or 8, the fire code official shall prepare a fire/life safety notice in writing that the building be repaired and modified to conform to the minimum requirements of said Sections. The notice shall specify in what manner the building fails to meet the minimum requirements of Section 903.2.20.2, subsection 6, 7, or 8. It shall direct that plans be submitted, and that necessary permits be obtained not later than one (1) year after the service of the notice, and that necessary corrections be completed not later than three (3) years thereafter for work required under Section 903.2.20.2, subsection 6, not later than four (4) years thereafter for work required under Section 903.2.20.2, subsection 7 and not later than five (5) years thereafter for work required under Section 903.2.20.2, subsection 8. The notice shall be transmitted by the fire code official for enforcement purposes. The fire code official shall serve the notice either personally or by certified or registered mail upon the owner as shown on the last equalized assessment roll and upon the person, if any, in real or apparent charge or control of the building. The provisions of this Section 903.2.20.2.1 are not intended to prevent the fire code official from also making a determination or issuing an order regarding failure to comply with Section 903.2.20.2, subsection 6, 7, or 8.
2. Recordation. At the time that the fire code official serves the aforementioned order or notice, the fire code official shall file with the Office of the County Recorder, a certificate stating that the subject building does not meet the minimum fire safety requirements of Section

903.2.20.2, subsection 6, 7, or 8 and that the owner thereof has been so notified. After all necessary corrective work has been performed; the fire code official shall file with the Office of the County Recorder, a certificate terminating the status of the subject building as nonconforming to the minimum fire safety requirements of Section 903.2.20.2, subsection 6, 7, or 8.

3. Enforcement. If the owner or other person in charge and control of the subject building fails to comply with the aforementioned order or notice within the time periods set forth in Section 903.2.20.2.1, such person is guilty of a misdemeanor punishable by a fine or by imprisonment or both. A person is guilty of a separate offense each day during which he or she commits, continues or permits a violation of Section 903.2.20.2, subsection 6, 7, or 8. The fire code official shall also order that the building owner or other person in charge and control post a notice of non-conformance. The notice shall be placed in a conspicuous area of the building until all required corrective work has been completed.

SECTION IA-33. Section [F] 906.8 of Volume IA of the Glendale Building and Safety Code, 2023 is hereby amended to read as follows:

[F] 906.8 Cabinets. Cabinets used to house portable fire extinguishers shall not be locked.

Exceptions:

1. Where portable fire extinguishers subject to malicious use or damage are provided with a means of ready access.
2. In Group I-3 occupancies and in mental health areas in Group I-2 occupancies, access to portable fire extinguishers shall be permitted to be locked or to be located in staff locations provided the staff has keys.

In new construction, fire extinguishers shall be located within recessed or semi-recessed cabinets. In existing occupancies, fire extinguishers shall be located within recessed or semi-

recessed cabinets when required by the fire code official. Cabinets should be mounted at no higher than four feet (1219 mm) above the floor to the top of the cabinet. Fire extinguishers shall be mounted with the brackets or hangers within the cabinets.

Exception: Surface mounted cabinets may be installed when construction material makes recessing the cabinet impracticable.

SECTION IA-34. Section [F] 906.9.1 of Volume IA of the Glendale Building and Safety Code, 2023, is hereby amended to read as follows:

[F] 906.9.1 Extinguishers weighing 40 pounds or less. Portable fire extinguishers having a gross weight not exceeding 40 pounds (18kg) shall be installed so that their tops are not more than 48 inches (1219 mm) above the floor.

SECTION IA-35. Section [F] 907.6.6 of Volume IA of the Glendale Building and Safety Code, 2023, is hereby amended to read as follows:

[F] 907.6.6 Monitoring. Fire alarm systems required by this chapter or by the *California Building Code* shall be monitored by an approved supervising station in accordance with NFPA 72 and this section. Supervising stations shall be listed by Underwriters Laboratories, Inc., or approved equal.

Exception: Supervisory service is not required for:

1. Single- and multiple-station smoke alarms required by Section 907.2.11.
2. Group I-3 occupancies *shall be monitored in accordance with Section 907.2.6.3.*
3. *Automatic sprinkler systems* in one-and two-family dwellings.

SECTION IA-36. Section [F] 907.10 of Volume IA of the Glendale Building and Safety Code, 2023, is hereby added to read as follows:

[F] 907.9 Certification and Identification of Certificated Systems.

907.9.1 New Systems. All new fire alarm systems shall maintain a valid Certificate as required by NFPA 72 Section 26.3 for the life of the system. The permittee and the listed contractor issuing the Certificate shall be one and the same.

907.9.2 Existing systems. The fire code official is authorized to order existing systems to provide central station service system monitoring if no monitoring exists, or upgrade existing monitoring to central station service system monitoring, in accordance with the provisions of Section 907.6.6 as amended, and this Section, when any one of the following conditions occur:

1. Systems produce three or more false or nuisance alarm activations within a 12-month period.
2. Systems become unmaintainable or unreliable due to dilapidation or deterioration as determined by the fire code official.
3. Upon replacement of the fire alarm control unit, or when 25% or more of the devices are replaced.
4. A change in occupancy occurs to a more hazardous use as determined by the fire code official.

Exception: Group R Division 3 occupancies.

907.11.3 Identification of certificated systems. All existing and new fire alarm systems for which a Certificate is required shall be identified with an approved, tamper resistant label on the fire alarm control panel. The label shall, at a minimum, show the following: certificate number; the name, address, phone number, listing number, and California contractor's license number of the certificate holder; a warning statement to the effect that no person or entity is authorized to perform any work on the system without the express permission and authorization of the contractor/certificate holder, and that the certification may be voided in such case; a statement

that a valid certificate is required to be in effect for the life of the system, and; a statement that by order of the fire code official the label shall not be removed.

SECTION IA-37. Section [F] 913.7 of Volume IA of the Glendale Building and Safety Code, 2023, is hereby added to read as follows:

[F] 913.7 Fire pumps and pump rooms.

913.7.1 Pump sizing. Fire pumps shall be sized to meet the required demands based upon 100% of the listed pump capacity.

913.7.2 Pump room. All fire pumps shall be located in a dedicated room. The room shall not be used for any other equipment or use.

913.7.3 High rise buildings. A minimum of two fire pumps independently driven shall be provided for all new high-rise buildings. The pumps shall be arranged and controlled so as to automatically switch should one fail. Each pump shall be provided with a secondary power supply as approved by the fire code official. One or both pumps shall receive their water directly from the municipal water supply.

SECTION IA-38. Table 1004.5 of Volume IA of the Glendale Building and Safety

Code, 2023, is hereby amended to read as follows:

**TABLE 1004.1.2
MAXIMUM FLOOR AREA ALLOWANCES PER OCCUPANT**

FUNCTION OF SPACE	OCCUPANT LOAD FACTOR ^a
Accessory storage areas, mechanical equipment room	300 gross
Agricultural building	300 gross
Aircraft hangars	500 gross
Airport terminal	
Baggage claim	20 gross
Baggage handling	300 gross
Concourse	100 gross
Waiting areas	15 gross
Assembly	
Gaming floors (keno, slots, etc.)	11 gross
Billiard/Pool Table	8 per table
Exhibit Gallery and Museum	30 net
Assembly with fixed seats	See section 1004.4
Assembly without fixed seats	
Concentrated (chairs only-not fixed)	7 net
Standing space	5 net
Unconcentrated (tables and chairs)	15 net
Bowling centers, allows 5 persons for each lane including 15 feet of runway, and for additional areas	7 net
Business areas	150 gross
Concentrated business use areas	See Section 1004.8
Courtrooms-other than fixed seating areas	40 net
Day care	35 net
Dormitories	50 gross
Educational	
Classroom area	20 net
Shops and other vocational room areas	50 net
Exercise rooms	50 gross
Garment manufacturing	50 gross
Group H-5 Fabrication and manufacturing areas	200 gross
Industrial areas	100 gross

TABLE 1004.1.2 Continued
MAXIMUM FLOOR AREA ALLOWANCES PER OCCUPANT

FUNCTION OF SPACE	OCCUPANT LOAD FACTOR ^a
Institutional areas	
Inpatient treatment areas	240 gross
Outpatient areas	100 gross
Sleeping areas	120 gross
Kitchens, commercial	200 gross
Laboratory	
Educational (K-12 th grade)	50 net
Laboratories, non-educational	100 net
Laboratory suite ^b	200 gross
Library	
Reading rooms	50 net
Stack area	100 gross
Locker rooms	50 gross
Mall buildings – covered and open	See Section 402.8.2
Mercantile	
Areas on other floors	60 gross
Storage, stock, shipping areas	300 gross
Parking garages	200 gross
Residential	200 gross
Skating rinks, swimming pools	
Rink and pool	50 gross
Decks	15 gross
Stages and platforms	15 net
Warehouses	500 gross

For SI: 1 square foot = 0.0929 m²

- a. Floor area in square feet per occupant.
- b. See Section 453.2.

SECTION IA-39. TABLE 1006.2.1 of Volume IA of the Glendale Building and Safety

Code, 2023, is hereby amended to read as follows:

**TABLE 1006.2.1
SPACES WITH ONE EXIT OR EXIT ACCESS DOORWAY**

OCCUPANCY	MAXIMUM OCCUPANT LOAD OF SPACE	MAXIMUM COMMON PATH OF EGRESS TRAVEL DISTANCE (feet)		
		Without Sprinkler System (feet)		With Sprinkler System (feet)
		Occupant Load		
		OL ≤ 30	OL ≥ 30	
A ^c , E, M	49	75	75	75 ^a
B	49	100	75	100 ^a
F	49	75	75	100 ^a
H-1, H-2, H-3	3	NP	NP	25 ^b
H-4, H-5	10	NP	NP	75 ^b
I-2 ^d , I-2.1, I-4	10	NP	NP	75 ^a
I-3	10	NP	NP	100 ^a
R-1	10	NP	NP	75 ^a
R-2	20	NP	NP	125 ^a
R-2.1	10	NP	NP	75 ^a
R-2.2	20	NP	NP	125 ^a
R-3 ^e , R-3.1 ^e	20	NP	NP	125 ^{a, g}
R-4 ^e	20	NP	NP	125 ^{a, g}
S ^f	29	100	75	100 ^a
U	49	100	75	75 ^a
L	See Section 453.6.1		NP	NP

For SI: 1 foot = 304.8 mm.

NP = Not Permitted

- a. Buildings equipped throughout with an automatic sprinkler system in accordance with Section 903.3.1.1 or 903.3.1.2. See Section 903 for occupancies where automatic sprinkler systems are permitted in accordance with Section 903.3.1.2.
- b. Group H occupancies equipped throughout with an automatic sprinkler system in accordance with Section 903.2.5.
- c. For a room or space used for assembly purposes having fixed seating, see Section 1029.8.
- d. For the travel distance limitations and number of exit and exit access requirements for rooms and spaces in Group I-2 or I-2.1, see Section 407.4.
- e. The common path of egress travel distance shall only apply in a Group R-3 occupancy located in a mixed occupancy building.
- f. The length of common path of egress travel distance in a Group S-2 open parking garage shall be not more than 100 feet.
- g. For the travel distance limitation in Group R-3 and R-4 equipped throughout with an automatic sprinkler system in accordance with Section 903.3.1.3, see Section 1006.2.2.6.
- h. For holding cells, see Section 408.3.11.
- ~~i. Garment manufacturing maximum occupant load is 29.~~
- i. In accordance with Health and safety Code Section 13113(d), there is no requirement for automatic sprinkler protection in an existing Group I-2 located in Type IA construction.

SECTION IA-40. Section 1505.1 of Volume IA of the Glendale Building and Safety Code, 2023, is hereby amended to read as follows:

1505.1 General. Roof assemblies shall be divided into the classes defined below. Class A and B roof assemblies and roof coverings required to be listed by this section shall be tested in accordance with ASTM E 108 or UL 790. The minimum roof coverings installed on buildings shall comply with Table 1505.1 based on the type of construction of the building. The roof-covering assembly includes the roof deck, underlayment, interlayment, insulation and covering which is assigned a roof covering classification. No wood roof covering material shall be installed. See Chapter 7A for roofing requirements in Wildland Urban Interface Fire Areas (also known as High Fire Hazard Areas).

Exceptions:

1. Skylights and sloped glazing that comply with Chapter 24 or Section 2610.
2. Penthouses shall be constructed as required in Section 1510.2.

SECTION IA-41. TABLE 1505.1 of Volume IA of the Glendale Building and Safety Code, 2023, is hereby amended to read as follows:

**TABLE 1505.1^a
MINIMUM ROOF COVERING CLASSIFICATION
FOR TYPES OF CONSTRUCTION**

IA	IB	IIA	IIB	IIIA	IIIB	IV	VA	VB
B	B	B	B	B	B	B	B	B

For SI: 1 foot = 304.8 mm, 1 square foot = 0.0929 m².

- a. Unless otherwise required in accordance with *Chapter 7A*-for Wildland Urban Interface Fire Areas (also known as High Fire Hazard Areas).

SECTION IA-42. Section 1505.1.3 of Volume IA of the Glendale Building and Safety Code, 2023, is hereby amended to read as follows:

1505.1.3 Roof coverings within all other areas. *The entire roof covering of every existing structure where more than 50 percent of the total roof area is replaced within any one-year period, the entire roof covering of every new structure, and any roof covering applied in the alteration, repair or replacement of the roof of every existing structure, shall be a fire-retardant roof covering that is at least Class B. No wood roof covering shall be installed.*

SECTION IA-43. Section 1507.3.1 of Volume IA of the Glendale Building and Safety Code, 2023, is hereby amended to read as follows:

1507.3.1 Deck requirements. Concrete and clay tile shall be installed only over solid sheathing.

Exceptions: Spaced lumber shall be permitted in Seismic Design Categories A, B and C.

SECTION IA-44. Table 1507.3.7 of Volume IA of the Glendale Building and Safety Code, 2023 is hereby amended to read as follows:

TABLE 1507.3.7

CLAY AND CONCRETE TILE ATTACHMENT^{a, b, c}

GENERAL—CLAY OR CONCRETE ROOF TILE			
Maximum Allowable Stress Design Wind Speed, V_{asd}^f (mph)	Mean roof height (feet)	Roof slope up to < 3:12	Roof slope 3:12 and over
85	0-60	Two fasteners per tile. Flat tile without vertical laps, two fasteners per tile.	Two fasteners per tile. Two fasteners on slopes of 7:12 and less for tiles with installed weight exceeding 7.5 lbs./sq. ft. having a width no greater than 16 inches.
100	0-40		
100	> 40-60	The head of all tiles shall be nailed. The nose of all eave tiles shall be fastened with approved clips. All rake tiles shall be nailed with two nails. The nose of all ridge, hip and rake tiles shall be set in a bead of roofer's mastic.	
110	0-60	The fastening system shall resist the wind forces in Section 1609.5.3 minimum 2 fasteners per tile.	
120	0-60	The fastening system shall resist the wind forces in Section 1609.5.3 minimum 2 fasteners per tile.	

130	0-60	The fastening system shall resist the wind forces in Section 1609.5.3 minimum 2 fasteners per tile.
All	>60	The fastening system shall resist the wind forces in Section 1609.5.3 minimum 2 fasteners per tile.
INTERLOCKING CLAY OR CONCRETE ROOF TILE WITH PROJECTING ANCHOR LUGS (Installations on solid sheathing without battens)		
Maximum Allowable Stress Nominal Design Wind Speed, V_{asd}¹ (mph)	Mean roof height (feet)	All roof slopes
85	0-60	Two fasteners per tile.
100	0-40	Two fasteners per tile.
100	> 40-60	The head of all tiles shall be nailed. The nose of all eave tiles shall be fastened with approved clips. All rake tiles shall be nailed with two nails. The nose of all ridge, hip and rake tiles shall be set in a bead of roofer's mastic.
110	0-60	The fastening system shall resist the wind forces in Section 1609.5.3 minimum two fasteners per tile.
120	0-60	The fastening system shall resist the wind forces in Section 1609.5.3 minimum two fasteners per tile.
130	0-60	The fastening system shall resist the wind forces in Section 1609.5.3 minimum two fasteners per tile.
All	> 60	The fastening system shall resist the wind forces in Section 1609.5.3 minimum two fasteners per tile.

Notes to Table 1507.3.7:

For SI : 1 inch = 25.4 mm, 1 foot = 304.8 mm, 1 mile per hour = 0.447 m/s, 1 pound per square foot = 4.882 kg/m².

- a. Minimum fastener size. Hot dipped galvanized ring shank or other approved corrosion-resistant nails not less than No. 11 gage with ⁵/₁₆-inch head. Fasteners shall be long enough to penetrate into the sheathing ³/₄-inch or through the thickness of the sheathing, whichever is less. Attaching wire for clay and concrete tile shall not be smaller than 0.083 inch.
- b. Snow areas. A minimum of two fasteners per tile are required or battens and one fastener.
- c. Roof slopes greater than 24:12. The nose of all tiles shall be securely fastened.
- d. Horizontal battens. Battens shall be not less than 1 inch by 2 inch nominal. Provisions shall be made for drainage by a minimum of ¹/₈-inch riser at each nail or by 4-foot-

long battens with at least a 0.5-inch separation between battens. Horizontal battens are required for slopes over 7:12.

- e. Perimeter fastening areas include three tile courses but not less than 36 inches from either side of hips or ridges and edges of eaves and gable rakes.
- f. V_{asd} shall be determined in accordance with Section 1609.3.1.

SECTION IA-45. Section 1511.7 of Volume IA of the Glendale Building and Safety Code, 2023, is hereby added to read as follows:

1511.7 Roof sheathing. When finish roofing material is removed to the existing space sheathing, a minimum of 3/8 inch (9 mm) thick plywood sheathing shall be installed. See Chapter 7A for roof coverings permitted in the Wildland Urban Interface Fire Areas (also known as High Fire Hazard Areas). The new sheathing shall comply with the requirements of Section 2306.2. The sheathing shall be installed such that the edges align over rafters and individual spaced sheathing boards. The sheathing shall be attached to the existing spaced sheathing with 6d common nails at 6 inches (147 mm) on center at supported edges and 6d common nails at 12 inches (294 mm) on center at intermediate supports.

SECTION IA-46. Section 1613.5 of Volume IA of the Glendale Building and Safety Code, 2023, is hereby added to Chapter 16 to read as follows:

1613.5 Amendments to ASCE 7. The provision of Section 1613.5 shall be permitted as an amendment to the relevant provisions of ASCE 7.

SECTION IA-47. Section 1613.5.1 of Volume IA of the Glendale Building and Safety Code, 2023, is hereby added to Chapter 16 to read as follows:

1613.5.1 Values for Vertical Combinations. Modify ASCE 7 Section 12.2.3.1 Exception 3 as follows:

3. Detached one-and two-family dwellings up to two stories in height of light frame construction.

SECTION IA-48. Section 1613.5.2 of Volume IA of the Glendale Building and Safety Code, 2023, is hereby added to read as follows:

1613.5.2 Wood Diaphragms. Modify ASCE 7 Section 12.11.2.2.3 to read as follows:

12.11.2.2.3 **Wood diaphragms.** The anchorage of concrete or masonry structural walls to wood diaphragms shall be in accordance with AWC SDPWS 4.1.5.1 and this section. Continuous ties required by this section shall be in addition to the diaphragm sheathing. Anchorage shall not be accomplished by use of toenails or nails subject to withdrawal, nor shall wood ledgers or framing be used in cross-grain bending or cross-grain tension. The diaphragm sheathing shall not be considered effective for providing the ties or struts required by this section.

For structures assigned to Seismic Design Category D, E or F, wood diaphragms supporting concrete or masonry walls shall comply with the following:

1. The spacing of continuous ties shall not exceed 40 feet. Added chords of diaphragms may be used to form subdiaphragms to transmit the anchorage forces to the main continuous crossties.
2. The maximum diaphragm shear used to determine the depth of the subdiaphragm shall not exceed 75% of the maximum diaphragm shear.

SECTION IA-49. Section 1613.5.3 of Volume IA of the Glendale Building and Safety Code, 2023, is hereby added to read as follows:

1613.5.3 Structural Separation. Modify ASCE 7 Section 12.12.3 Equation 12.12-1 as follows:

$$\delta_M = C_d \delta_{\max}$$

Attachment 3_[1A] GBSC_2023_Volume IA

(12.12-1)

SECTION IA-50. Section 1613.6 of Volume IA of the Glendale Building Code, 2023, is hereby added to read as follows:

1613.6 Seismic design provisions for hillside buildings.

1613.6.1 Purpose. The purpose of this section is to establish minimum regulations for the design and construction of new buildings and additions to existing buildings when constructing such buildings on or into slopes steeper than one unit vertical in three units horizontal (33.3%). These regulations establish minimum standards for seismic force resistance to reduce the risk of injury or loss of life in the event of earthquakes.

1613.6.2 Scope. The provisions of this section shall apply to the design of the lateral-force-resisting system for hillside buildings at and below the base level diaphragm. The design of the lateral-force-resisting system above the base level diaphragm shall be in accordance with the provisions for seismic and wind design as required elsewhere in this division.

Exception: Non-habitable accessory buildings and decks not supporting or supported from the main building are exempt from these regulations.

1613.6.3 Definitions. For the purposes of this section certain terms are defined as follows:

BASE LEVEL DIAPHRAGM is the floor at, or closest to, the top of the highest level of the foundation.

DIAPHRAGM ANCHORS are assemblies that connect a diaphragm to the adjacent foundation at the uphill diaphragm edge.

DOWNHILL DIRECTION is the descending direction of the slope approximately perpendicular to the slope contours.

FOUNDATION is concrete or masonry which supports a building, including footings, stem walls, retaining walls, and grade beams.

FOUNDATION EXTENDING IN THE DOWNHILL DIRECTION is a foundation running downhill and approximately perpendicular to the uphill foundation.

HILLSIDE BUILDING is any building or portion thereof constructed on or into a slope steeper than one unit vertical in three units horizontal (33.3%). If only a portion of the building is supported on or into the slope, these regulations apply to the entire building.

PRIMARY ANCHORS are diaphragm anchors designed for and providing a direct connection as described in Sections 1613.6.5 and 1613.6.7.3 between the diaphragm and the uphill foundation.

SECONDARY ANCHORS are diaphragm anchors designed for and providing a redundant diaphragm to foundation connection, as described in Sections 1613.6.6 and 1613.6.7.4.

UPHILL DIAPHRAGM EDGE is the edge of the diaphragm adjacent and closest to the highest ground level at the perimeter of the diaphragm.

UPHILL FOUNDATION is the foundation parallel and closest to the uphill diaphragm edge.

1613.6.4 Analysis and design.

1613.6.4.1 General. Every hillside building within the scope of this section shall be analyzed, designed, and constructed in accordance with the provisions of this division. When the code-prescribed wind design produces greater effects, the wind design shall govern, but detailing requirements and limitations prescribed in this and referenced sections shall be followed.

1613.6.4.2 Base level diaphragm-downhill direction. The following provisions shall apply to the seismic analysis and design of the connections for the base level diaphragm in the downhill direction.

1613.6.4.2.1 Base for lateral force design defined. For seismic forces acting in the downhill direction, the base of the building shall be the floor at or closest to the top of the highest level of the foundation.

1613.6.4.2.2 Base shear. In developing the base shear for seismic design, the response modification coefficient (R) shall not exceed 5 for bearing wall and building frame systems. The total base shear shall include the forces tributary to the base level diaphragm including forces from the base level diaphragm.

1613.6.5 Base shear resistance-primary anchors.

1613.6.5.1 General. The base shear in the downhill direction shall be resisted through primary anchors from diaphragm struts provided in the base level diaphragm to the foundation.

1613.6.5.2 Location of primary anchors. A primary anchor and diaphragm strut shall be provided in line with each foundation extending in the downhill direction. Primary anchors and diaphragm struts shall also be provided where interior vertical lateral-force-resisting elements occur above and in contact with the base level diaphragm. The spacing of primary anchors and diaphragm struts or collectors shall in no case exceed 30 feet (9144 mm).

1613.6.5.3 Design of primary anchors and diaphragm struts. Primary anchors and diaphragm struts shall be designed in accordance with the requirements of Section 1613.6.8.

1613.6.5.4 Limitations. The following lateral-force-resisting elements shall not be designed to resist seismic forces below the base level diaphragm in the downhill direction:

1. Wood structural panel wall sheathing,
2. Cement plaster and lath,
3. Gypsum wallboard, and
4. Tension only braced frames.

Braced frames designed in accordance with the requirements of Section 2205.2.1.2 may be used to transfer forces from the primary anchors and diaphragm struts to the foundation provided lateral forces do not induce flexural stresses in any member of the frame or in the diaphragm struts. Deflections of frames shall account for the variation in slope of diagonal members when the frame is not rectangular.

1613.6.6 Base shear resistance-secondary anchors.

1613.6.6.1 General. In addition to the primary anchors required by Section 1613.6.5, the base shear in the downhill direction shall be resisted through secondary anchors in the uphill foundation connected to diaphragm struts in the base level diaphragm.

Exception: Secondary anchors are not required where foundations extending in the downhill direction spaced at not more than 30 feet (9144 mm) on center extend up to and are directly connected to the base level diaphragm for at least 70% of the diaphragm depth.

1613.6.6.2 Secondary anchor capacity and spacing. Secondary anchors at the base level diaphragm shall be designed for a minimum force equal to the base shear, including forces tributary to the base level diaphragm, but not less than 600 pounds per lineal foot

(8.76 kN/m) based on Allowable Stress Design (ASD) levels. The secondary anchors shall be uniformly distributed along the uphill diaphragm edge and shall be spaced a maximum of 4 feet (1219 mm) on center.

1613.6.6.3 Design. Secondary anchors and diaphragm struts shall be designed in accordance with Section 1613.6.8.

1613.6.7 Diaphragms below the base level-downhill direction. The following provisions shall apply to the lateral analysis and design of the connections for all diaphragms below the base level diaphragm in the downhill direction.

1613.6.7.1 Diaphragm defined. Every floor level below the base level diaphragm shall be designed as a diaphragm.

1613.6.7.2 Design force. Each diaphragm below the base level diaphragm shall be designed for all tributary loads at that level using a minimum seismic force factor not less than the base shear coefficient.

1613.6.7.3 Design force resistance-primary anchors. The design force described in Section 1613.6.7.2 shall be resisted through primary anchors from diaphragm struts provided in each diaphragm to the foundation. Primary anchors shall be provided and designed in accordance with the requirements and limitations of Section 1613.6.5.

1613.6.7.4 Design force resistance-secondary anchors.

1613.6.7.4.1 General. In addition to the primary anchors required in Section 1613.6.7.3, the design force in the downhill direction shall be resisted through secondary anchors in the uphill foundation connected to diaphragm struts in each diaphragm below the base level.

Exception: Secondary anchors are not required where foundations extending in the downhill direction, spaced at not more than 30 feet (9144 mm) on center, extend up to and are directly connected to each diaphragm below the base level for at least 70% of the diaphragm depth.

1613.6.7.4.2 Secondary anchor capacity. Secondary anchors at each diaphragm below the base level diaphragm shall be designed for a minimum force equal to the design force but not less than 300 pounds per lineal foot (4.38 kN/m) based on Allowable Stress Design (ASD) levels. The secondary anchors shall be uniformly distributed along the uphill diaphragm edge and shall be spaced a maximum of 4 feet (1219 mm) on center.

1613.6.7.4.3 Design. Secondary anchors and diaphragm struts shall be designed in accordance with Section 1613.6.8.

1613.6.8 Primary and secondary anchorage and diaphragm strut design. Primary and secondary anchors and diaphragm struts shall be designed in accordance with the following provisions:

1. Fasteners. All bolted fasteners used to develop connections to wood members shall be provided with square plate washers at all bolt heads and nuts. Washers shall be minimum 0.229 inch by 3 inches by 3 inches (5.82 mm by 76 mm by 76 mm) in size. Nuts shall be tightened to finger tight plus one half (1/2) wrench turn prior to covering the framing.
2. Fastening. The diaphragm to foundation anchorage shall not be accomplished by the use of toenailing, nails subject to withdrawal, or wood in cross-grain bending or cross-grain tension.

3. Size of Wood Members. Wood diaphragm struts collectors, and other wood members connected to primary anchors shall not be less than 3 inch (76 mm) nominal width. The effects of eccentricity on wood members shall be evaluated as required per Item 9.
4. Design. Primary and secondary anchorage, including diaphragm struts, splices, and collectors shall be designed for 125% of the tributary force.
5. Allowable Stress Increase. The one-third allowable stress increase permitted under Section 1605.3.2 shall not be taken when the working (allowable) stress design method is used.
6. Steel Element of Structural Wall Anchorage System. The strength design forces for steel elements of the structural wall anchorage system, with the exception of anchor bolts and reinforcing steel, shall be increased by 1.4 times the forces otherwise required.
7. Primary Anchors. The load path for primary anchors and diaphragm struts shall be fully developed into the diaphragm and into the foundation. The foundation must be shown to be adequate to resist the concentrated loads from the primary anchors.
8. Secondary Anchors. The load path for secondary anchors and diaphragm struts shall be fully developed in the diaphragm but need not be developed beyond the connection to the foundation.
9. Symmetry. All lateral force foundation anchorage and diaphragm strut connections shall be symmetrical. Eccentric connections may be permitted when demonstrated by calculation or tests that all components of force have been provided for in the structural analysis or tests.

10. Wood Ledgers. Wood ledgers shall not be used to resist cross-grain bending or cross-grain tension.

1613.6.9 Lateral-force-resisting elements normal to the downhill direction.

1613.6.9.1 General. In the direction normal to the downhill direction, lateral-force-resisting elements shall be designed in accordance with the requirements of this section.

1613.6.9.2 Base shear. In developing the base shear for seismic design, the response modification coefficient (R) shall not exceed 5 for bearing wall and building frame systems.

1613.6.9.3 Vertical distribution of seismic forces. For seismic forces acting normal to the downhill direction the distribution of seismic forces over the height of the building using Section 12.8.3 of ASCE 7 shall be determined using the height measured from the top of the lowest level of the building foundation.

1613.6.9.4 Drift limitations. The story drift below the base level diaphragm shall not exceed 0.007 times the story height at strength design force level. The total drift from the base level diaphragm to the top of the foundation shall not exceed 3/4 inch (19 mm). Where the story height or the height from the base level diaphragm to the top of the foundation varies because of a stepped footing or story offset, the height shall be measured from the average height of the top of the foundation. The story drift shall not be reduced by the effect of horizontal diaphragm stiffness.

1613.6.9.5 Distribution of lateral forces.

1613.6.9.5.1 General. The design lateral force shall be distributed to lateral-force-resisting elements of varying heights in accordance with the stiffness of each individual element.

1613.6.9.5.2 Wood structural panel sheathed walls. The stiffness of a stepped wood structural panel shear wall may be determined by dividing the wall into adjacent rectangular elements, subject to the same top of wall deflection. Deflections of shear walls may be estimated by AWC SDPWS Section 4.3.2. Sheathing and fastening requirements for the stiffest section shall be used for the entire wall. Each section of wall shall be anchored for shear and uplift at each step. The minimum horizontal length of a step shall be 8 feet (2438 mm) and the maximum vertical height of a step shall be 2 feet 8 inches (813 mm).

1613.6.9.5.3 Reinforced concrete or masonry shear walls. Reinforced concrete or masonry shear walls shall have forces distributed in proportion to the rigidity of each section of the wall.

1613.6.9.6 Limitations. The following lateral force-resisting-elements shall not be designed to resist lateral forces below the base level diaphragm in the direction normal to the downhill direction:

1. Cement plaster and lath,
2. Gypsum wallboard, and
3. Tension-only braced frames.

Braced frames designed in accordance with the requirements of Section 2205.2.1.2 of this Code may be designed as lateral-force-resisting elements in the direction normal to the downhill direction, provided lateral forces do not induce flexural stresses in any member of the frame. Deflections of frames shall account for the variation in slope of diagonal members when the frame is not rectangular.

1613.6.10 Specific design provisions.

1613.6.10.1 Footings and grade beams. All footings and grade beams shall comply with the following:

1. Grade beams shall extend at least 12 inches (305 mm) below the lowest adjacent grade and provide a minimum 24 inch (610 mm) distance horizontally from the bottom outside face of the grade beam to the face of the descending slope.
2. Continuous footings shall be reinforced with at least two No. 4 reinforcing bars at the top and two No. 4 reinforcing bars at the bottom.
3. All main footing and grade beam reinforcement steel shall be bent into the intersecting footing and fully developed around each corner and intersection.
4. All concrete stem walls shall extend from the foundation and reinforced as required for concrete or masonry walls.

1613.6.10.2 Protection against decay and termites. All wood to earth separation shall comply with the following:

1. Where a footing or grade beam extends across a descending slope, the stem wall, grade beam, or footing shall extend up to a minimum 18 inches (457 mm) above the highest adjacent grade.

Exception: At paved garage and doorway entrances to the building, the stem wall need only extend to the finished concrete slab, provided the wood framing is protected with a moisture proof barrier.

2. Wood ledgers supporting a vertical load of more than 100 pounds per lineal foot (1.46 kN/m) based on Allowable Stress Design (ASD) levels and located within 48 inches (1219 mm) of adjacent grade are prohibited. Galvanized steel ledgers

and anchor bolts, with or without wood nailers, or treated or decay resistant sill plates supported on a concrete or masonry seat, may be used.

1613.6.10.3 Sill plates. All sill plates and anchorage shall comply with the following:

1. All wood framed walls, including nonbearing walls, when resting on a footing, foundation, or grade beam stem wall, shall be supported on wood sill plates bearing on a level surface.
2. Power-driven fasteners shall not be used to anchor sill plates except at interior nonbearing walls not designed as shear walls.

1613.6.10.4 Column base plate anchorage. The base of isolated wood posts (not framed into a stud wall) supporting a vertical load of 4,000 pounds (17.8 kN) based on Allowable Stress Design (ASD) levels or more and the base plate for a steel column shall comply with the following:

1. When the post or column is supported on a pedestal extending above the top of a footing or grade beam, the pedestal shall be designed and reinforced as required for concrete or masonry columns. The pedestal shall be reinforced with a minimum of four No. 4 bars extending to the bottom of the footing or grade beam. The top of exterior pedestals shall be sloped for positive drainage.
2. The base plate anchor bolts or the embedded portion of the post base, and the vertical reinforcing bars for the pedestal, shall be confined with two No. 4 or three No. 3 ties within the top 5 inches (127 mm) of the concrete or masonry pedestal. The base plate anchor bolts shall be embedded a minimum of 20 bolt diameters into the concrete or masonry pedestal. The base plate anchor bolts and post bases

shall be galvanized and each anchor bolt shall have at least 2 galvanized nuts above the base plate.

1613.6.10.5 Steel beam to column supports. All steel beam to column supports shall be positively braced in each direction. Steel beams shall have stiffener plates installed on each side of the beam web at the column. The stiffener plates shall be welded to each beam flange and the beam web. Each brace connection or structural member shall consist of at least two 5/8 inch (15.9 mm) diameter machine bolts.

SECTION IA-51. Section 1613.7 of Volume IA of the Glendale Building Code, 2023, is hereby added to read as follows:

1613.7 Suspended ceilings. Minimum design and installation standards for suspended ceilings shall be determined in accordance with the requirements of Section 2506.2.1 of this Code and this section.

1613.7.1 Scope. This part contains special requirements for suspended ceilings and lighting systems. Provisions of Section 13.5.6 of ASCE 7 shall apply except as modified herein.

1613.7.2 General. The suspended ceilings and lighting systems shall be limited to 6 feet (1828 mm) below the structural deck unless the lateral bracing is designed by a licensed engineer or architect.

1613.7.3 Sprinkler Heads. All sprinkler heads (drops) except fire-resistance-rated floor/ceiling or roof/ceiling assemblies, shall be designed to allow for free movement of the sprinkler pipes with oversize rings, sleeves or adaptors through the ceiling tile. Sprinkler heads and other penetrations shall have a 2 inch (50 mm) oversize ring, sleeve, or adapter through the ceiling tile to allow for free movement of at least 1 inch (25 mm)

in all horizontal directions. Alternatively, a swing joint that can accommodate 1 inch (25 mm) of ceiling movement in all horizontal directions is permitted to be provided at the top of the sprinkler head extension.

Sprinkler heads penetrating fire-resistance-rated floor/ceiling or roof/ceiling assemblies shall comply with Section 714 of this code.

1613.7.4 Special requirements for means of egress. Suspended ceiling assemblies located along means of egress serving an occupant load of 30 or more and at lobbies accessory to Group A Occupancies shall comply with the following provisions:

1613.7.4.1 General. Ceiling suspension systems shall be connected and braced with vertical hangers attached directly to the structural deck along the means of egress serving an occupant load of thirty (30) or more and at lobbies accessory to Group A Occupancies. Spacing of vertical hangers shall not exceed 2 feet (610 mm) on center along the entire length of the suspended ceiling assembly located along the means of egress or at the lobby.

1613.7.4.2 Assembly Device. All lay-in panels shall be secured to the suspension ceiling assembly with two hold-down clips minimum for each tile within a 4-foot (1219 mm) radius of the exit lights and exit signs.

1613.7.4.3 Emergency Systems. Independent supports and braces shall be provided for light fixtures required for exit illumination. Power supply for exit illumination shall comply with the requirements of Section 1006.3 of this Code.

1613.7.4.4 Supports for Appendage. Separate support from the structural deck shall be provided for all appendages such as light fixtures, air diffusers, exit signs, and similar elements.

SECTION IA-52. Section 1701.2 of Volume IA of the Glendale Building and Safety Code, 2020, is hereby added to read as follows:

1701.2 Technical specialties. As required by the building official, due to specific project concerns or when a project contains construction where special expertise is needed, the building official may require the work to be observed, inspected or certified by a third party, provided by the owner or contractor and approved by the building official, that has certification or demonstrated expertise in the identified construction.

SECTION IA-53. Section 1704.2 of Volume IA of the Glendale Building and Safety Code, 2020, is hereby amended to read as follows:

1704.2 Special inspections and tests. Where application is made to the building official for construction as specified in Section 105 or 1.8.4, as applicable, the owner or the owner's authorized agent, other than the contractor, shall employ one or more approved agencies to provide special inspections and tests during construction on the types of work specified in Section 1705 and identify the approved agencies to the building official. These special inspections and tests are in addition to the inspections by the building official that are identified in Section 110.

[OSHPD 1R, 2 & 5] In addition, the approved agencies shall provide special inspections and tests during construction on the types of work listed under Chapters 17, 18, 19, 20, 21, 22, 23 and 25, and noted in the Test, Inspection and Observation (TIO) program as required by the Office.

The inspectors shall act under the direction of the architect or structural engineer or both, and be responsible to the Owner. Where California Administrative Code Section 7-115(a) 2 permits construction documents to be prepared under the responsible charge of a mechanical

engineer, electrical or civil engineer. inspectors shall be permitted to work under the direction of an engineer in the appropriate branch as permitted therein.

Exceptions:

1. Special inspections and tests are not required for construction of a minor nature or as warranted by conditions in the jurisdiction as approved by the building official.
2. Special inspections and tests are not required for portions of structures designed and constructed in accordance with the cold-formed steel light-frame construction provisions of *Section 2211.1.2* or the conventional light-frame construction provisions of *Section 2308*. *[OSHPD 1R, 2 & 5] Not permitted by OSHPD.*
3. The contractor is permitted to employ the approved agencies where the contractor is also the owner. *[OSHPD 1R, 2 & 5] Not permitted by OSHPD.*
4. *[HCD 1] The provisions of Health and Safety Code Division 13, Part 6 and the California Code of Regulations, Title 25, Division 1, Chapter 3, commencing with Section 3000, shall apply to the construction and inspection of factory-built housing as defined in Health and Safety Code Section 19971.*

SECTION IA-54. Section 1704.6 of Volume IA of the Glendale Building and Safety Code, 2023, is hereby amended to read as follows:

1704.6 Structural Observations. Where required by the provisions of Section 1704.6.1, the owner or the owner's authorized agent shall employ a structural observer to perform structural observations. The structural observer shall visually observe locations of structural systems, details and load paths for general conformance to the approved construction documents.

Structural observation does not include or waive the responsibility for the inspections in Section 110 or the special inspections in Section 1705 or other sections of this code. The structural observer shall be one of the following individuals:

1. The registered design professional responsible for the structural design, or
2. A registered design professional designated by the registered design professional responsible for the structural design.

The requirement for structural observation shall be noted and prominently displayed on the front sheet of the approved plans and incorporated into the general notes on the approved plans.

Prior to the commencement of observations, the structural observer shall submit to the building official a written statement identifying the frequency and extent of structural observations.

The owner or owner's authorized agent shall coordinate and call a preconstruction meeting between the structural observer, contractors, affected subcontractors and special inspectors. The structural observer shall preside over the meeting. The purpose of the meeting shall be to identify the major structural elements and connections that affect the vertical and lateral load resisting systems of the structure and to review scheduling of the required observations. A record of the meeting shall be included in the report submitted to the Building Official.

Observed deficiencies shall be reported in writing to the owner or owner's authorized agent, special inspector, contractor and the Building Official. Upon the form prescribed by the Building Official, the structural observer shall submit to the Building Official a written statement at each significant construction stage stating that the site visits have been made and identifying any reported deficiencies which, to the best of the structural observer's knowledge, have not been

resolved. A final report by the structural observer which states that all observed deficiencies have been resolved is required before acceptance of the work by the Building Official.

SECTION IA-55. Section 1704.6.1 of Volume IA of the Glendale Building and Safety Code, 2023, is hereby amended to read as follows:

1704.6.2 Structural observations for structures. Structural observations shall be provided for Those structures where one or more of the following conditions exist:

2. The structure is classified as Risk Category II or IV.
3. The structure is a high-rise building.
4. The structure is classified as Risk Category I or II, and a lateral design is required for the structure or portion thereof.

Exception: One-story wood frame Group R-3 and Group U Occupancies less than 2,000 square feet in area, provided the adjacent grade is not steeper than 1 unit vertical in 10 units horizontal (10% sloped), assigned to Seismic Design Category D.

5. Such observation is required by the registered design professional for the structural design.
6. Such observation is specifically required by the building official.
7. The requirement for structural observation shall be noted and prominently displayed on the front sheet of the approved plans and incorporated into the general notes on the approved plans.

SECTION IA-56. Section 1705.3 of Volume IA of the Glendale Building and Safety Code, 2023, is hereby amended to read as follows:

1705.3 Concrete construction. Special inspections and tests of concrete construction shall be performed in accordance with this section and Table 1705.3.

Exceptions: Special inspections and tests shall not be required for:

1. Isolated spread concrete footings of buildings three stories or less above grade plane that are fully supported on earth or rock, where the structural design of the footing is based on a specified compressive strength, f'_c , not more than 2,500 pounds per square inch (psi) (17.2 MPa) regardless of the compressive strength specified in the construction documents or used in the footing construction.
2. Continuous concrete footings supporting walls of buildings three stories or less above grade plane that are fully supported on earth or rock where:
 - 2.1. The footings support walls of light-frame construction;
 - 2.2. The footings are designed in accordance with Table 1809.7; or
 - 2.3. The structural design of the footing is based on a specified compressive strength, f'_c , not more than 2,500 pounds per square inch (psi) (17.2 MPa), regardless of the compressive strength specified in the construction documents or used in the footing construction.
3. Nonstructural concrete slabs supported directly on the ground, including prestressed slabs on grade, where the effective prestress in the concrete is less than 150 psi (1.03 MPa).
4. Concrete patios, driveways and sidewalks, on grade.

SECTION IA-57. Section 1705.13 of Volume IA of the Glendale Building and Safety Code, 2023, is hereby amended to read as follows:

1705.13 Special inspections for seismic resistance. Special inspections for seismic resistance shall be required as specified in Sections 1705.13.1 through 1705.13.9, unless exempted by the exceptions of Section 1704.2.

Exceptions: The special inspections specified in Sections 1705.13.1 through 1705.13.9 are not required for structures designed and constructed in accordance with one of the following:

1. The structure consists of light-frame construction; the design spectral response acceleration at short periods, S_{DS} , as determined in Section 1613.2.4, does not exceed 0.5; and the building height of the structure does not exceed 35 feet (10,688 mm).
2. The seismic force-resisting system of the structure consists of reinforced masonry or reinforced concrete; the design spectral response acceleration at short periods, S_{DS} , as determined in Section 1613.2.4, does not exceed 0.5; and the building height of the structure does not exceed 25 feet (7620 mm).
3. The structure is a detached one- or two-family dwelling not exceeding two stories above grade plane, is not assigned to Seismic Design Category D, E or F_z, and does not have any of the following horizontal or vertical irregularities in accordance with Section 12.3 of ASCE 7:
 - 3.1 Torsional or extreme torsional irregularity.
 - 3.2 Nonparallel systems irregularity.
 - 3.3 Stiffness-soft story or stiffness-extreme soft story irregularity.
 - 3.4 Discontinuity in lateral strength-weak story irregularity.

SECTION IA-58. Section 1805.4.3 of Volume IA of the Glendale Building and Safety Code, 2023, is hereby amended to read as follows:

1805.4.3 Drainage discharge. The floor base and foundation perimeter drain shall discharge by gravity or mechanical means into an approved drainage system that complies with the *California*

Plumbing Code. On all building sites, and other parcels where natural drainage is altered, drainage devices acceptable to the Building Official and the City Engineer shall be installed to conduct concentrated storm water to a location approved by the City Engineer.

Exception: Where a site is located in well-drained gravel or sand or sand/gravel mixture soils, a dedicated drainage system is not required.

SECTION IA-59. Section 1807.1.4 of Volume IA of the Glendale Building and Safety Code, 2023, is hereby amended to read as follows:

1807.1.4 Permanent wood foundation systems. Permanent wood foundation systems shall be designed and installed in accordance with AWC PWF. Lumber and plywood shall be ~~preservative~~ treated in accordance with AWPA U1 (Commodity Specification A, Special Requirement 4.2) and shall be identified in accordance with Section 2303.1.9.1. Permanent wood foundation systems shall not be used for structures assigned to Seismic Design Category D, E or F.

SECTION IA-60. Section 1807.1.6 of Volume IA of the Glendale Building and Safety Code, 2023, is hereby amended to read as follows:

1807.1.6 Prescriptive design of concrete and masonry foundation walls. Concrete and masonry foundation walls that are laterally supported at the top and bottom shall be permitted to be designed and constructed in accordance with this section. Prescriptive design of foundation walls shall not be used for structures assigned to Seismic Design Category D, E or F.

SECTION IA-61. Section 1807.2 of Volume IA of the Glendale Building and Safety Code, 2023, is hereby amended to read as follows:

1807.2 Retaining walls. Retaining walls shall be designed in accordance with Section 1807.2.1 through 1807.2.4. Retaining walls assigned to Seismic Design Category D, E or F shall not be partially or wholly constructed of wood.

SECTION IA-62. Section 1807.3.1 of Volume IA of the Glendale Building and Safety Code, 2023, is hereby amended to read as follows:

1807.3.1 Limitations. The design procedures outlined in this section are subject to the following limitations:

1. The frictional resistance for structural walls and slabs on silts and clays shall be limited to one-half of the normal force imposed on the soils by the weight of the footing or slab.
2. Posts embedded in earth shall not be used to provide lateral support for structural or nonstructural materials such as plaster, masonry or concrete unless bracing is provided that develops the limited deflection required.

Wood poles shall be treated in accordance with AWWA U1 for sawn timber posts (Commodity Specification A, Use Category 4B) and for round timber posts (Commodity Specification B, Use Category 4B). Wood poles and posts embedded in direct contact with soil shall not be used for structures assigned to Seismic Design Category D, E or F.

Exception: Wood poles and posts embedded in direct contact with soil may be used to support nonhabitable, nonoccupiable structures such as fences when approved by the building official.

SECTION IA-63. Section 1809.3 of Volume IA of the Glendale Building and Safety Code, 2023, is hereby amended to read as follows:

1809.3 Stepped footings. The top surface of footings shall be level. The bottom surface of footings shall be permitted to have a slope not exceeding one unit vertical in 10 units horizontal (10-percent slope). Footings shall be stepped where it is necessary to change the elevation of the top surface of the footing or where the surface of the ground slopes more than one unit vertical in 10 units horizontal (10-percent slope).

For structures assigned to Seismic Design Category D, E or F, the stepping requirement shall also apply to the top surface of continuous footings supporting walls. Footings shall be reinforced with four No. 4 deformed reinforcing bars. Two bars shall be placed at the top and bottom of the footings as shown in Figure 1809.3

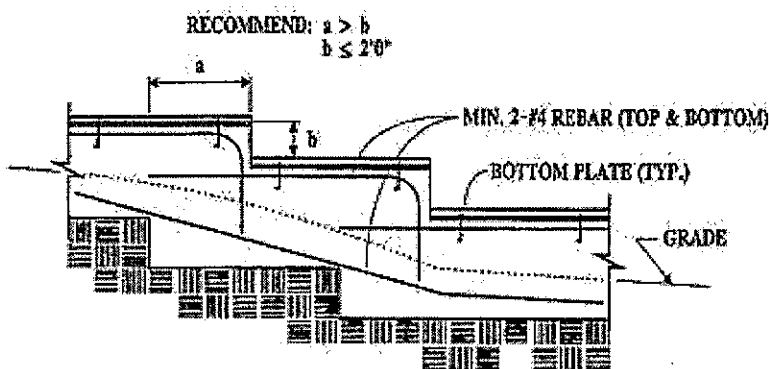

STEPPED FOUNDATIONS

**FIGURE 1809.3
STEPPED FOOTING**

SECTION IA-64. Section 1809.7 of Volume IA of the Glendale Building and Safety Code, 2023, is hereby amended to read as follows:

1809.7 Prescriptive footings for light-frame construction. Where a specific design is not provided, concrete or masonry-unit footing supporting walls of light-frame construction shall be permitted to be designed in accordance with Table 1809.7. Light-frame construction using

prescriptive footings in Table 1809.7 shall not exceed one story above grade plane for structures assigned to Seismic Design Category D, E or F.

SECTION IA-65. Table 1809.7 of Volume IA of the Glendale Building and Safety Code, 2023, is hereby amended to read as follows:

**TABLE 1809.7
PRESCRIPTIVE FOOTINGS SUPPORTING WALLS OF
LIGHT-FRAME CONSTRUCTION ^{a, b, c, d, e}**

NUMBER OF FLOORS SUPPORTED BY THE FOOTING ^f	WIDTH OF FOOTING (inches)	THICKNESS OF FOOTING (inches)
1	12	6
2	15	6
3	18	8 ^g

For SI: 1 inch = 25.4 mm, 1 foot = 304.8 mm

- a. Depth of footings shall be in accordance with Section 1809.4.
- b. The ground under the floor shall be permitted to be excavated to the elevation of the top of the footing.
- c. Not Adopted.
- d. See Section 1905 for additional requirements for concrete footings of structures assigned to Seismic Design Category C, D, E or F.
- e. For thickness of foundation walls, see Section 1807.1.6.
- f. Footings shall be permitted to support a roof addition to the stipulated number of floors. Footings supporting roof only shall be as required for supporting one floor.

SECTION IA-66. Section 1809.12 of Volume IA of the Glendale Building and Safety Code, 2023, is hereby amended to read as follows:

1809.12 Timber footings. Timber footings shall be permitted for buildings of Type V construction and as otherwise approved by the Building Official. Such footings shall be treated in accordance with AWP A U1 (Commodity Specification A, Use Category 4B). Treated timbers are not required where placed entirely below permanent water level, or where used as capping for wood piles that project above the water level over submerged or marsh lands. The compressive stresses perpendicular to grain in untreated timber footings supported on treated piles shall not exceed 70 percent of the allowable stresses for the species and grade of timber as specified in the ANSI/AWC NDS. Timber footings shall not be used in structures assigned to Seismic Design Category D, E or F.

SECTION IA-67. Section 1810.3.2.4 of Volume IA of the Glendale Building and Safety Code, 2023, is hereby amended to read as follows:

1810.3.2.4 Timber. Timber deep foundation elements shall be designed as piles or poles in accordance with ANSI/AWC NDS. Round timber elements shall conform to ASTM D 25. Sawn timber elements shall conform to DOC PS-20. Timber deep foundation elements shall not be used in structures assigned to Seismic Design Category D, E or F.

SECTION IA-68. Section 1905.1 of Volume IA of the Glendale Building and Safety Code, 2023, is hereby amended to read as follows and subsections 1905.1.1 shall remain as set forth in the California Building Code, 2022:

1905.1 General. The text of ACI 318 shall be modified as indicated in Sections 1905.1.1 through 1905.1.11.

SECTION IA-69. Section 1905.1.7 of Volume IA of the Glendale Building and Safety Code, 2023, is hereby amended to read as follows:

1905.1.7 ACI 318, Section 14.1.4. Delete ACI 318, Section 14.1.4, and replace with the following:

14.1.4 - Plain concrete in structures assigned to Seismic Design Category C, D, E or F.

14.1.4.1 - Structures assigned to Seismic Design Category C, D, E or F shall not have elements of structural plain concrete, except as follows:

- (a) Concrete used for fill with a minimum cement content of two (2) sacks of Portland cement or cementitious material per cubic yard.*
- (b) Isolated footings of plain concrete supporting pedestals or columns are permitted, provided the projection of the footing beyond the face of the supported member does not exceed the footing thickness.*
- (c) Plain concrete footings supporting walls are permitted provided the footings have at least two continuous longitudinal reinforcing bars. Bars shall not be smaller than No. 4 and shall have a total area of not less than 0.002 times the gross cross-sectional area of the footing. A minimum of one bar shall be provided at the top and bottom of the footing. Continuity of reinforcement shall be provided at corners and intersections.*

Exceptions:

- 1. Detached one- and two-family dwellings three stories or less in height and constructed with stud-bearing walls, are permitted to have plain concrete footings with at least two continuous longitudinal reinforcing bars not smaller than No. 4 are permitted to have a total area of less than 0.002 times the gross cross-sectional area of the*

footing.

SECTION IA-70. Section 1905.1.9 of Volume IA of the Glendale Building and Safety Code, 2023, is hereby added to read as follows:

1905.1.9 ACI 318, Section 18.7.5. Modify ACI 318, Section 18.7.5, by adding Section 18.7.5. 8 and 18.7.5.9 as follows:

18.7.5.8 - Where the calculated point of contraflexure is not within the middle half of the member clear height, provide transverse reinforcement as specified in ACI 318 Sections 18.7.5.1, Items (a) through (c), over the full height of the member.

18.7.5.9 - At any section where the design strength, ϕP_n , of the column is less than the sum of the shears V_e computed in accordance with ACI 318 Sections 18.7.6.1 and 18.6.5.1 for all the beams framing into the column above the level under consideration, transverse reinforcement as specified in ACI 318 Sections 18.7.5.1 through 18.7.5.3 shall be provided. For beams framing into opposite sides of the column, the moment components are permitted to be assumed to be of opposite sign. For the determination of the design strength, ϕP_n , of the column, these moments are permitted to be assumed to result from the deformation of the frame in any one principal axis.

SECTION IA-71. Section 1905.1.10 of Volume IA of the Glendale Building and Safety Code, 2023, is hereby added to read as follows:

1905.1.10 ACI 318, Section 18.10.4. Modify ACI 318, Section 18.10.4, by adding Section 18.10.4.6 as follows:

18.10.4.7 Walls and portions of walls with $P_n > 0.35P_o$ shall not be considered to contribute to the calculated shear strength of the structure for resisting earthquake-induced forces. Such walls shall conform to the requirements of ACI 318 Section 18.14.

SECTION IA-72. Section 1905.1.11 of Volume IA of the Glendale Building and Safety Code, 2023, is hereby added to read as follows:

1905.1.11 ACI 318, Section 18.12.6. Modify ACI 318, by adding Section 18.12.6.2 as follows:

18.12.6.2 - Collector and boundary elements in topping slabs placed over precast floor and roof elements shall not be less than 3 inches (76 mm) or $6 d_b$ in thickness, where d_b is the diameter of the largest reinforcement in the topping slab.

SECTION IA-73. Section 2113.1 of Volume IA of the Glendale Building and Safety Code, 2023, is hereby amended to read as follows:

2113.1 General. The construction of masonry chimneys consisting of solid masonry units, hollow masonry units grouted solid, stone or concrete shall be in accordance with this section. Notwithstanding any other provisions of this code, an existing masonry chimney which is altered or repaired more than ten percent (10%) of its replacement cost within any twelve (12)-month period shall have its entire chimney structure comply with the current requirements of this code or other standards approved by the building official.

SECTION IA-74. Section 2304.10.2 of Volume IA of the Glendale Building and Safety Code, 2023, is hereby amended to read as follows:

2304.10.2 Fastener Requirements. Connections for wood members shall be designed in accordance with the appropriate methodology in Section 2302.1. The number and size of fasteners connecting wood members shall not be less than that set forth in Table 2304.10.2. Staples fasteners in Table 2304.10.2 shall not be used to resist or transfer seismic forces in structures assigned to Seismic Design Category D, E, or F.

Exception: Staples may be used to resist or transfer seismic forces when the allowable shear values are substantiated by cyclic testing and approved by the building official.

SECTION IA-75. Section 2304.10.3.1 of Volume IA of the Glendale Building and Safety Code, 2023, is hereby added to read as follows:

2304.10.3.1 Quality of nails. In Seismic Design Category D, E & F, mechanically driven nails used in wood structural panel shear walls shall meet the same dimensions as that required for hand-driven nails, including diameter, minimum length and minimum head diameter. Clipped head or box nails are not permitted in new construction. The allowable design value for clipped head nails in existing construction may be taken at no more than the nail-head-area ratio of that of the same size hand-driven nails.

SECTION IA-76. Section 2304.12.2.8 of Volume IA of the Glendale Building and Safety Code, 2023, is hereby amended to read as follows.

2304.12.2.8 Wood used in retaining walls and cribs. Wood installed in retaining or crib walls shall be preservative treated in accordance with AWPA U1 for soil and fresh water use. Wood shall not be used in retaining or crib walls for structures assigned to Seismic Design Category D, E or F.

SECTION IA-77. Section 2305.4 of Volume IA of the Glendale Building and Safety Code, 2023, is hereby added to read as follows:

2305.4 Hold-down connectors. In Seismic Design Category D, E or F, hold-down connectors shall be designed to resist shear wall overturning moments using approved cyclic load values or 75 percent of the allowable seismic load values that do not consider cyclic loading of the product. Connector bolts into wood framing shall require steel plate washers on the post on the opposite side of the anchorage device. Plate size shall be a minimum of 0.229 inch by 3 inches by 3 inches (5.82 mm by 76 mm by 76 mm) in size. Hold-down connectors shall be tightened to finger tight plus one half (1/2) wrench turn just prior to covering the wall framing.

SECTION IA-78. Section 2306.2 of Volume IA of the Glendale Building and Safety Code, 2023, is hereby amended to read as follows:

2306.2 Wood-frame diaphragms. Wood-frame diaphragms shall be designed and constructed in accordance with AWC SDPWS. Where panels are fastened to framing members with staples, requirements and limitations of AWC SDPWS shall be met and the allowable shear values set forth in Table 2306.2(1) or 2306.2(2) shall only be permitted for structures assigned to Seismic Design Category A, B, or C.

Exception: Allowable shear values where panels are fastened to framing members with staples may be used if such values are substantiated by cyclic testing and approved by the building official.

The allowable shear values in Tables 2306.2(1) and 2306.2(2) are permitted to be increased 40 percent for wind design.

Wood structural panel diaphragms used to resist seismic forces in structures assigned to Seismic Design Category D, E or F shall be applied directly to the framing members.

Exception: Wood structural panel diaphragms are permitted to be fastened over solid lumber planking or laminated decking, provided the panel joints and lumber planking or laminated decking joints do not coincide.

SECTION IA-79. Section 2306.3 of Volume IA of the Glendale Building and Safety Code, 2023, is hereby amended to read as follows:

2306.3 Wood-frame shear walls. Wood-frame shear walls shall be designed and constructed in accordance with AWC SDPWS. For structures assigned to Seismic Design Category D, E, or F, application of Tables 4.3A and 4.3B of AWC SDPWS shall include the following:

1. Wood structural panel thickness for shear walls shall not be less than 3/8 inch thick and studs shall not be spaced at more than 16 inches on center.
2. The maximum nominal unit shear capacities for 3/8 inch wood structural panels resisting seismic forces in structures assigned to Seismic Design Category D, E or F is 560 pounds per linear foot (plf).

Exception: Other nominal unit shear capacities may be permitted if such values are substantiated by cyclic testing and approved by the building official.

3. Nails shall be placed not less than 1/2 inch in from the panel edges and not less than 3/8 inch from the edge of the connecting members for shear greater than 350 plf using ASD or 500 plf using LRFD. Nails shall be placed not less than 3/8 inch from panel edges and not less than 1/4 inch from the edge of the connecting members for shears of 350 plf or less using ASD or 500 plf or less using LRFD.
4. Table 4.3B application is not allowed for structures assigned to Seismic Design Category D, E, or F.

For structures assigned to Seismic Design Category D, application of Table 4.3C of AWC SDPWS shall not be used below the top level in a multi-level building.

Where panels are fastened to framing members with staples, requirements and limitations of AWC SDPWS shall be met and the allowable shear values set forth in Table 2306.3(1), 2306.3(2) or 2306.3(3) shall only be permitted for structures assigned to Seismic Design Category A, B, or C.

Exception: Allowable shear values where panels are fastened to framing members with staples may be used if such values are substantiated by cyclic testing and approved by the building official.







The allowable shear values in Tables 2306.3(1) and 2306.3(2) are permitted to be increased 40 percent for wind design. Panels complying with ANSI/APA PRP-210 shall be permitted to use design values for Plywood Siding in the AWC SDPWS.

SECTION IA-80. Section 2307.2 of Volume IA of the Glendale Building and Safety Code, 2023, is added to the 2022 Edition of the California Building Code to read as follows:

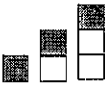
2307.2 Wood-frame shear walls. Wood-frame shear walls shall be designed and constructed in accordance with Section 2306.3 as applicable.

SECTION IA-81. Table 2308.6.1 of Volume IA of the Glendale Building and Safety Code, 2023, is hereby amended to read as follows:

TABLE 2308.6.1*
WALL BRACING REQUIREMENTS

SEISMIC DESIGN CATEGORY	STORY CONDITION (SEE SECTION 2308.2)	MAXIMUM SPACING OF BRACED WALL LINES	BRACED PANEL LOCATION, SPACING (O.C.) AND MINIMUM PERCENTAGE (%)			MAXIMUM DISTANCE OF BRACED WALL PANELS FROM EACH END OF BRACED WALL LINE
			Bracing method ^b			
			LIB	DWB, WSP	SFB, PBS, PCP, HPS, GB ^{c,d}	
A and B		35'-0"	Each end and ≤ 25'-0" o.c.	Each end and ≤ 25'-0" o.c.	Each end and ≤ 25'-0" o.c.	12'-6"
		35'-0"	Each end and ≤ 25'-0" o.c.	Each end and ≤ 25'-0" o.c.	Each end and ≤ 25'-0" o.c.	12'-6"
		35'-0"	NP	Each end and ≤ 25'-0" o.c.	Each end and ≤ 25'-0" o.c.	12'-6"
C		35'-0"	NP	Each end and ≤ 25'-0" o.c.	Each end and ≤ 25'-0" o.c.	12'-6"
		35'-0"	NP	Each end and ≤ 25'-0" o.c. (minimum 25% of wall length) ^e	Each end and ≤ 25'-0" o.c. (minimum 25% of wall length) ^e	12'-6"
D and E <i>f, g, h</i>		25'-0"	NP	$S_{DS} < 0.50$: Each end and ≤ 25'-0" o.c. (minimum 21% of wall length) ^e	$S_{DS} < 0.50$: Each end and ≤ 25'-0" o.c. (minimum 43% of wall length) ^e	8'-0"
				$0.5 \leq S_{DS} < 0.75$: Each end and ≤ 25'-0" o.c. (minimum 32% of wall length) ^e	$0.5 \leq S_{DS} < 0.75$: Each end and ≤ 25'-0" o.c. (minimum 59% of wall length) ^e	
				$0.75 \leq S_{DS} \leq 1.00$: Each end and ≤ 25'-0" o.c. (minimum 37% of wall length) ^e	$0.75 \leq S_{DS} \leq 1.00$: Each end and ≤ 25'-0" o.c. (minimum 75% of wall length)	
				$S_{DS} > 1.00$: Each end and ≤ 25'-0" o.c. (minimum 48% of wall length) ^e	$S_{DS} > 1.00$: Each end and ≤ 25'-0" o.c. (minimum 100% of wall length) ^e	

For SI: 1 inch = 25.4 mm, 1 foot = 304.8 mm.

NP = Not Permitted.

a. This table specifies minimum requirements for braced wall panels along interior or exterior braced wall lines.

b. See Section 2308.6.3 for full description of bracing methods.

c. For Method GB, gypsum wallboard applied to framing supports that are spaced at 16 inches on center.

d. The required lengths shall be doubled for gypsum board applied to only one face of a braced wall panel.

e. Percentage shown represents the minimum amount of bracing required along the building length (or wall length if the structure has an irregular shape).

f. DWB, SFB, PBS, and HPS wall braces are not permitted in Seismic Design Categories D or E.

g. Minimum length of panel bracing of one face of the wall for WSP sheathing shall be at least 4'-0" long or both faces of the wall for GB or PCP sheathing shall be at least 8'-0" long; h/w ratio shall not exceed 2:1. Wall framing to which sheathing used for bracing is applied shall be nominal 2 inch wide (actual 1 1/2 inch (38 mm) or larger members) and spaced a maximum of 16 inches on center. Braced wall panel construction types shall not be mixed within a braced wall line.

h. WSP sheathing shall be a minimum of 15/32" thick nailed with 8d common placed 3/8 inches from panel edges and spaced not more than 6 inches on center and 12 inches on center along intermediate framing members.

SECTION IA-82. Section 2308.6.5.1 of Volume IA of the Glendale Building and Safety Code, 2023, is hereby amended to read as follows:

2308.6.5.1 Alternate bracing wall (ABW). An ABW shall be constructed in accordance with this section and Figure 2308.6.5.1. In one-story buildings, each panel shall have a length of not less than 2 feet 8 inches (813 mm) and a height of not more than 10 feet (3,048 mm). Each panel shall be sheathed on one face with 3/8-inch (3.2 mm) minimum-thickness wood structural panel sheathing nailed with 8d common or galvanized box nails in accordance with Table 2304.10.1 and blocked at wood structural panel edges. For structures assigned to Seismic Design Category D or E, each panel shall be sheathed on one face with 15/32-inch-minimum-thickness (11.9 mm) wood structural panel sheathing nailed with 8d common nails spaced 3 inches at intermediate on panel edges, 3 inches at intermediate supports. Two anchor bolts installed in accordance with Section 2308.3.1 shall be provided in each panel. Anchor bolts shall be placed at each panel outside quarter points. Each panel end stud shall have a hold-down device fastened to the foundation, capable of providing an approved uplifted capacity of not less than 1,800 pounds (8,006 N). The hold-down device shall be installed in accordance with the manufacturer's recommendations. The ABW shall be supported directly on a foundation or on floor framing supported directly on a foundation that is continuous across the entire length of the braced wall line. This foundation shall be reinforced with not less than one No. 4 bar top and bottom. Where the continuous foundation is required to have a depth greater than 12 inches (305 mm), a minimum 12-inch by 12-inch (305 mm by 305 mm) continuous footing is permitted at door openings in the braced wall line. This continuous footing shall be reinforced with not less than

one No. 4 bar top and bottom. This reinforcement shall be lapped 24 inches (610 mm) with the reinforcement required in the continuous foundation located directly under the braced wall line.

Where the ABW is installed at the first story of two-story buildings, the wood structural panel sheathing shall be provided on both faces, three anchor bolts shall be placed at one-quarter points and tie-down device uplift capacity shall be not less than 3,000 pounds (13 344 N).

SECTION IA-83. Figure 2308.6.5.1 of Volume IA of the Glendale Building and Safety Code, 2023, is hereby amended to read as follows:

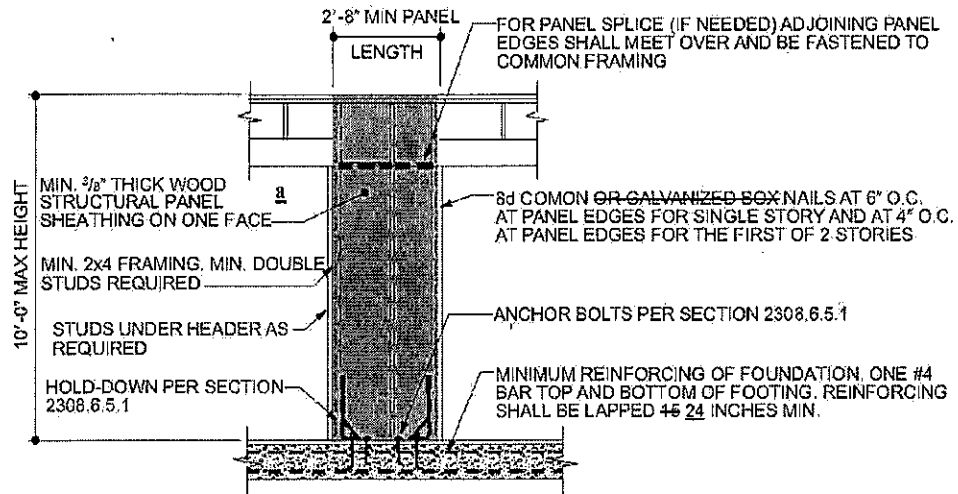

For SI: 1 inch = 25.4 mm, 1 foot = 304.8 mm.

a. For structures assigned to Seismic Design Category D or E, sheathed on one face with 15/32-inch minimum thickness (11.9 mm) wood structural panel sheathing.

**FIGURE 2308.6.5.1
ALTERNATE BRACED WALL PANEL (ABW)**

SECTION IA-84. Section 2308.6.5.2 of Volume IA of the Glendale Building and Safety Code, 2023, is hereby amended to read as follows:

2308.6.5.2 Portal frame with hold-downs (PFH). A PFH shall be constructed in accordance with this section and Figure 2308.6.5.2. The adjacent door or window opening shall have a full-length header.

In one-story buildings, each panel shall have a length of not less than 16 inches (406 mm) and a height of not more than 10 feet (3048 mm). Each panel shall be sheathed on one face with

a single layer of 3/8-inch (9.5 mm) minimum-thickness wood structural panel sheathing nailed with 8d common or galvanized box nails in accordance with Figure 2308.6.5.2. For structures assigned to Seismic Design Category D or E, each panel shall be sheathed on one face with 15/32-inch-minimum-thickness (11.9 mm) wood structural panel sheathing nailed with 8d common nails spaced 3 inches on panel edges, 3 inches at intermediate supports and in accordance with Figure 2308.6.5.2. The wood structural panel sheathing shall extend up over the solid sawn or glued-laminated header and shall be nailed in accordance with Figure 2308.6.5.2. A built-up header consisting of at least two 2-inch by 12-inch (51 mm by 305 mm) boards, fastened in accordance with Item 26 of Table 2304.10.2 shall be permitted to be used. A spacer, if used, shall be placed on the side of the built-up beam opposite the wood structural panel sheathing. The header shall extend between the inside faces of the first full-length outer studs of each panel. The clear span of the header between the inner studs of each panel shall be not less than 6 feet (1829 mm) and not more than 18 feet (5486 mm) in length. A strap with an uplift capacity of not less than 1,000 pounds (4,400 N) shall fasten the header to the inner studs opposite the sheathing. One anchor bolt not less than 5/8 inch (15.9 mm) diameter and installed in accordance with Section 2308.3.1 shall be provided in the center of each sill plate. The studs at each end of the panel shall have a hold-down device fastened to the foundation with an uplift capacity of not less than 3,500 pounds (15 570 N).

Where a panel is located on one side of the opening, the header shall extend between the inside face of the first full-length stud of the panel and the bearing studs at the other end of the opening. A strap with an uplift capacity of not less than 1,000 pounds (4400 N) shall fasten the header to the bearing studs. The bearing studs shall also have a hold-down device fastened to the foundation with an uplift capacity of not less than 1,000 pounds (4400 N). The hold-down

devices shall be an embedded strap type, installed in accordance with the manufacturer's recommendations. The PFH panels shall be supported directly on a foundation that is continuous across the entire length of the braced wall line. This foundation shall be reinforced with not less than one No. 4 bar top and bottom. Where the continuous foundation is required to have a depth greater than 12 inches (305 mm), a minimum 12-inch by 12-inch (305 mm by 305 mm) continuous footing is permitted at door openings in the braced wall line. This continuous footing shall be reinforced with not less than one No. 4 bar top and bottom. This reinforcement shall be lapped not less than 24 inches (610 mm) with the reinforcement required in the continuous foundation located directly under the braced wall line.

Where a PFH is installed at the first story of two-story buildings, each panel shall have a length of not less than 24 inches (610 mm).

SECTION IA-85. Figure 2308.6.5.2 of Volume IA of the Glendale Building and Safety Code, 2023, is hereby amended to read as follows:

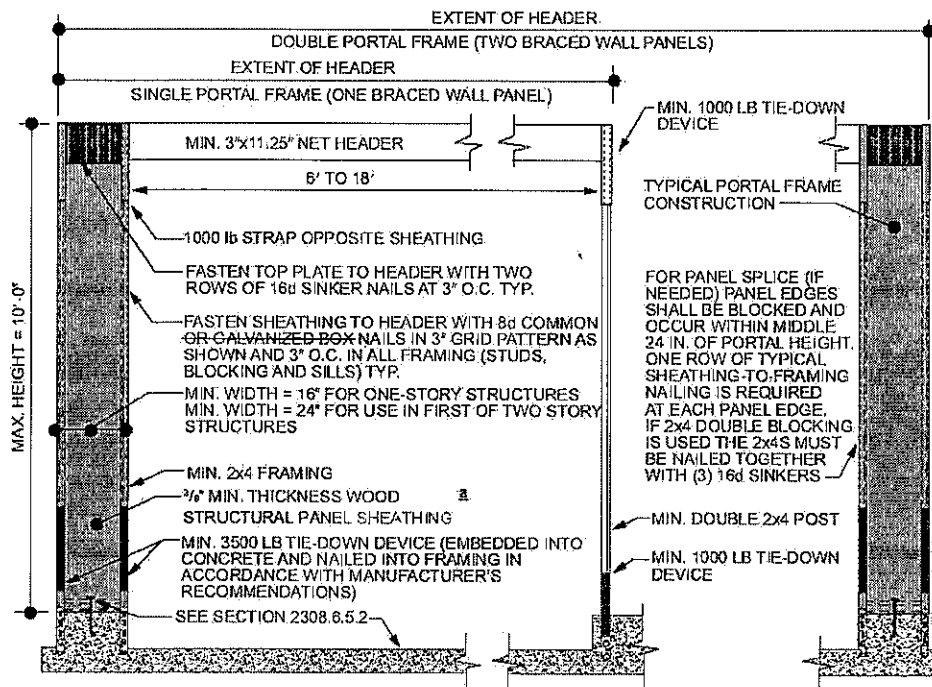

For SI: 1 inch = 25.4 mm, 1 foot = 304.8 mm, 1 pound = 4.448 N.

a. For structures assigned to Seismic Design Category D or E, sheathed on one face with 15/32-inch-minimum-thickness (11.9 mm) wood structural panel sheathing.

**FIGURE 2308.6.5.2
PORTAL FRAME WITH HOLD-DOWNS (PFH)**

SECTION IA-86. Section 2308.6.8.1 of Volume IA of the Glendale Building and Safety Code, 2023, is hereby amended to read as follows:

2308.6.8.1 Foundation requirements. Braced wall lines shall be supported by continuous foundations.

Exception: For structures with a maximum plan dimension not more than 50 feet (15,240 mm), continuous foundations are required at exterior walls only for structures assigned to seismic design category A, B or C.

For structures in Seismic Design Categories D and E, exterior braced wall panels shall be in the same plane vertically with the foundation or the portion of the structure containing the offset shall be designed in accordance with accepted engineering practice and Section 2308.1.1.1.

SECTION IA-87. Section 2308.6.9 of Volume IA of the Glendale Building and Safety Code, 2023, is hereby amended to read as follows:

2308.6.9 Attachment of sheathing. Fastening of braced wall panel sheathing shall not be less than that prescribed in Table 2308.6.1 or 2304.10.2. Wall sheathing shall not be attached to framing members by adhesives. Staple fasteners in Table 2304.10.2 shall not be used to resist or transfer seismic forces in structures assigned to Seismic Design Category D, E or F.

Exception: Staples may be used to resist or transfer seismic forces when the allowable shear values are substantiated by cyclic testing and approved by the building official.

All braced wall panels shall extend to the roof sheathing and shall be attached to parallel roof rafters or blocking above with framing clips (18 gauge minimum) spaced at maximum 24 inches (6096 mm) on center with four 8d nails per leg (total eight 8d nails per clip). Braced wall panels shall be laterally braced at each top corner and at maximum 24 inches (6096 mm) intervals along the top plate of discontinuous vertical framing.

SECTION IA-88. Section 3101.1 of Volume IA of the Glendale Building and Safety Code, 2023, is hereby amended to read as follows:

3101.1 Scope. The provisions of this chapter shall govern special building construction including membrane structures, temporary structures, pedestrian walkways and tunnels, automatic vehicular gates, awnings and canopies, marquees, signs, towers, antennas, relocatable buildings, swimming pool enclosures and safety devices, solar energy systems, public use restroom buildings on publicly owned lands in flood hazard areas and intermodal shipping containers.

SECTION IA-89. Section 3102.2.3 of Volume IA of the Glendale Building and Safety Code, 2023, is hereby added to read as follows:

3102.2.3 Membrane Structures Used as Shade Covers for Specific Uses. A membrane structure less than 20 feet (6096 mm) above grade may be installed as a shade cover at carwash drying areas and auto detailing areas or over playground equipment subject to the following requirements:

1. The structure shall be on grade.
2. The structure shall maintain a minimum fire separation distance of five feet from property lines.
3. The membrane shall be State Fire Marshal approved fire retardant fabric.
4. The membrane support structures shall be non-combustible.
5. Maintenance record shall be presented to the Fire Department during routine inspections and available at all times to show that the membrane material is less than 8 years old.
6. These structures are not required to be protected by an automatic fire sprinkler system.

For those cases which may affect fire or life safety in buildings regulated by the State Fire Marshall, the building official shall obtain the concurrence of the fire code official if related to fire protection systems, egress, fire department access or water supply.

SECTION IA-90. Section 3102.6.2 of Volume IA of the Glendale Building and Safety Code, 2023, is hereby added to read as follows:

3102.6.2 Membrane less than 20 feet (6096 mm). A noncombustible membrane less than 20 feet (6096 mm) above any floor, balcony or gallery shall be permitted for use as the roof or as a skylight of any building or atrium of a building of any type of construction and shall meet all of the following requirements:

1. A fire protection report may be required by the building official or fire official based on the fuel loads and ignition sources below the membrane.

AMERICAN SOCIETY OF MECHANICAL ENGINEERS

2. The membrane shall be a minimum of 10 feet (3048 mm) above any floor, balcony or gallery and shall have a minimum separation distance as required by the fire protection report and no less than 10 feet (3048 mm) above any fuel load or ignition source below the membrane.
3. The membrane shall be State Fire Marshal approved fire retardant fabric.
4. The membrane structure shall be a free standing, self supporting structure.
5. The membrane structure and all supports shall be non combustible.
6. The applicant shall enter into a Covenant and Agreement with the City of Glendale regarding the maintenance and replacement of the membrane.
7. A maintenance record of the membrane and membrane structure shall be provided on site by the property owner, and shall be provided to the fire department during annual inspections and/or upon request by the fire department.
8. The applicant shall apply for a building permit to replace the membrane every eight years.

SECTION IA-91. Section 3109.4.4.2 of Volume IA of the Glendale Building and Safety Code, 2023, is hereby amended to read as follows:

3109.4.4.2 Construction permit; safety features required. Commencing January 1, 2007, except as provided in Section 3109.4.4.5, whenever a building permit is issued for construction of a new swimming pool or spa, or any building permit is issued for remodeling of an existing pool or spa, at a private, single-family home, it shall be equipped with at least one of the following seven drowning prevention safety features:

1. *The pool shall be isolated from access to a home by an enclosure that meets the requirements of Section 3109.4.4.3.*

2. *The pool shall incorporate removable mesh pool fencing that meets American Society for Testing and Materials (ASTM) Specifications F 2286 standards in conjunction with a gate that is self-closing and self-latching and can accommodate a key lockable device.*
3. *The pool shall be equipped with an approved safety pool cover that meets all requirements of the ASTM Specifications F 1346.*
4. *The residence shall be equipped with exit alarms on those doors providing direct access to the pool.*
5. *All doors providing direct access from the home to the swimming pool shall be equipped with a self-closing, self-latching device with a release mechanism placed no lower than 54 inches (1372 mm) above the floor.*
6. *Swimming pool alarms that, when placed in pools, will sound upon detection of accidental or unauthorized entrance into the water. These pool alarms shall meet and be independently certified to the ASTM Standard F 2208 "Standards Specification for Pool Alarms" which includes surface motion, pressure, sonar, laser and infrared type alarms. For purposes of this article, "swimming pool alarms" shall not include swimming protection alarm devices designed for individual use, such as an alarm attached to a child that sounds when the child exceeds a certain distance or becomes submerged in water. Due to topographical conditions, swimming pool alarms will be accepted by the Building Official only on a case-by-case basis.*
7. *Other means of protection, if the degree of protection afforded is equal to or greater than that afforded by any of the devices set forth in items 1-4, and have been independently verified by an approved testing laboratory as meeting standards for those devices*

established by the ASTM or the American Society of Testing Mechanical Engineers (ASME).

Prior to the issuance of any final approval for the completion of permitted construction or remodeling work, the local building code official shall inspect the drowning safety prevention devices required by this act and if no violations are found, shall give final approval.

Authority: Health and Safety Code Section 18942(b)

Reference: Health and Safety Code Section 115922

AB 3305 (Statutes 1996, c.925); AB 2977 (Statutes 2006, c.478); AB 382 (Statutes 2007, c.596)

SECTION IA-92. Section 3109.4.4.3 of Volume IA of the Glendale Building and Safety Code, 2023, is hereby amended to read as follows:

3109.4.4.3 Enclosure; required characteristics. An enclosure shall have all of the following characteristics.

- 1. Any access gates through the enclosure open away from the swimming pool and are self-closing with a self-latching device placed no lower than 60 inches (1524 mm) above the ground.*
- 2. A minimum height of 60 inches (1524 mm).*
- 3. A maximum vertical clearance from the ground to the bottom of the enclosure of 2 inches (51mm).*
- 4. Gaps or voids, if any, do not allow passage of a sphere equal to or greater than 4 inches (102 mm) in diameter.*
- 5. An outside surface free of protrusions, cavities or other physical characteristics that would serve as handholds or footholds that could enable a child below the age of five years to climb over.*

6. When an ascending slope adjacent to a pool enclosure exceeds 45° from the horizontal the entire pool enclosure shall extend into the slope a minimum of 24 inches. The height of such extension shall be a minimum of 5 feet (1529 mm) measured perpendicular to the slope.

Authority: Health and Safety Code Section 18942 (b)

Reference: Health and Safety Code Section 115923

Ab 3305, Statutes 1996, c.925

SECTION IA-93. Section 3115 of Volume IA of the Glendale Building and Safety Code, 2023, is hereby amended to read as follows:

3115.1 General. The provisions of Section 3115 and other applicable sections of this code shall apply to intermodal shipping containers that are repurposed for use as buildings or structures or as a part of buildings or structures.

Exceptions:

1. Intermodal shipping containers previously approved as existing relocatable buildings complying with Chapter 14 of the California Existing Building Code.
2. Stationary battery storage arrays located in intermodal shipping containers complying with Chapter 12 of the California Fire Code.
3. Intermodal shipping containers that are listed as equipment complying with the standard for equipment, such as air chillers, engine generators, modular data centers, and other similar equipment.
4. Intermodal shipping containers housing or supporting experimental equipment are exempt from the requirements of Section 3115, provided they comply with all of the following:

- 4.1. Such units will be single stand-alone units supported at grade level and used only for occupancies as specified under Risk Category I in Table 1604.5.
 - 4.2. Such units are located a minimum of 8 feet (2438 mm) from adjacent structures, and are not connected to a fuel gas system or fuel gas utility.
 - 4.3. In hurricane-prone regions and flood hazard areas, such units are designed in accordance with the applicable provisions of Chapter 16.
5. *[HCD] Shipping containers constructed or converted off-site that meet the definition of Factory-built Housing in Health and Safety Code Section 19971 or Commercial Modular(s) as defined in Health and Safety Code Section 18001.8 shall be approved by the Department of Housing and Community Development.*
6. Single-unit stand-alone intermodal shipping containers used as temporary storage or construction trailer on active construction sites. Construction support facilities for uses and activities not directly associated with the actual processes of construction, including but not limited to, offices, meeting rooms, plan rooms, other administrative or support functions shall not be exempt from Section 3115.

3115.2 Construction documents. The construction documents shall contain information to verify the dimensions and establish the physical properties of the steel components and wood floor components of the intermodal shipping container, in addition to the information required by Sections 107 and 1603.

3115.3 Intermodal shipping container information. Intermodal shipping containers shall bear an existing data plate containing the following information as required by ISO 6346 and verified

by an approved agency. A report of the verification process and findings shall be provided to the building owner.

1. Manufacturer's name or identification number.
2. Date manufactured.
3. Safety approval number.
4. Identification number.
5. Maximum operating gross mass or weight (kg) (lbs).
6. Allowable stacking load for 1.8G (kg) (lbs).
7. Transverse racking test force (Newtons).
8. Valid maintenance examination date.

Where approved by the building official, the markings and existing data plate are permitted to be removed from the intermodal shipping containers before they are repurposed for use as buildings or structures or as part of buildings or structures.

3115.4 Protection against decay and termites. Wood structural floors of intermodal shipping containers shall be protected from decay and termites in accordance with the applicable provisions of Section 2304.12.1.1.

3115.5 Under-floor ventilation. The space between the bottom of the floor joists and the earth under any intermodal shipping container, except spaces occupied by basements and cellars, shall be provided with ventilation in accordance with Section 1202.4.

3115.6 Roof assemblies. Intermodal shipping container roof assemblies shall comply with the applicable requirements of Chapter 15.

Exception: Single-unit, stand-alone intermodal shipping containers not attached to, or stacked vertically over, other intermodal shipping containers, buildings or structures.

3115.7 Joints and voids. Joints and voids that create concealed spaces between ~~connected or stacked~~ intermodal shipping containers that are connected or stacked, at fire-resistance-rated walls, floor or floor/ceiling assemblies and roofs or roof/ceiling assemblies shall be protected by an approved fire-resistant joint system in accordance with section 715

3115.8 Structural. Intermodal shipping containers that conform to ISO 1496-1 and are repurposed for use as buildings or structures, or as a part of buildings or structures, shall be designed in accordance with Chapter 16 and this section.

3115.8.1 Foundations. Intermodal shipping containers repurposed for use as a permanent building or structure shall be supported on foundations or other supporting structures designed and constructed in accordance with Chapters 16 through 23.

3115.8.1.1 Anchorage. Intermodal shipping containers shall be anchored to foundations or other supporting structures as necessary to provide a continuous load path for all applicable design and environmental loads in accordance with Chapter 16.

3115.8.2 Welds. New welds and connections shall be equal to or greater than the original connections.

3115.8.3 Structural design. The structural design of the intermodal shipping containers repurposed for use as a building or structure, or as part of a building or structure, shall comply with Section 3115.8.4 or 3115.8.5.

3115.8.4 Detailed design procedure. A structural analysis meeting the requirements of this section shall be provided to the building official to demonstrate the structural adequacy of the intermodal shipping containers.

Exception: Intermodal shipping containers designed in accordance with Section 3115.8.5.

3115.8.4.1 Material properties. Structural material properties for existing intermodal shipping container steel components shall be established by material testing where the steel grade and composition cannot be identified by the manufacturer's designation as to manufacture and mill test.

3115.8.4.2 Seismic design parameters. The seismic force-resisting system shall be designed and detailed in accordance with one of the following:

1. Where all or portions of the corrugated steel container sides are considered to be the seismic force-resisting system, design and detailing shall be in accordance with the ASCE 7, Table 12.2-1 requirements for light-frame bearing-wall systems with shear panels of all other materials.
2. Where portions of corrugated steel container sides are retained, but are not considered to be the seismic force-resisting system, an independent seismic force-resisting system shall be selected, designed and detailed in accordance with ASCE 7, Table 12.2-1, or
3. Where portions of the corrugated steel container sides are retained and integrated into a seismic force-resisting system other than as permitted by Item 1, seismic design parameters shall be developed from testing and analysis in accordance with Section 104.11 and ASCE 7, Section 12.2.1.1 or 12.2.1.2.

3115.8.4.3 Allowable shear value. The allowable shear values for the intermodal shipping container corrugated steel sheet panel side walls and end walls shall be demonstrated by testing and analysis in accordance with Section 104.11. Where penetrations are made in the side walls or end walls designated as part of the lateral force-resisting system, the penetrations shall be substantiated by rational analysis.

3115.8.5 Simplified structural design procedure of single-unit containers. Single-unit intermodal shipping containers conforming to the limitations of Section 3115.8.5.1 shall be permitted to be designed in accordance with Sections 3115.8.5.2 and 3115.8.5.3.

3115.8.5.1 Limitations. Use of Section 3115.8.5 is subject to all the following limitations:

1. The intermodal shipping container shall be a single stand-alone unit supported on a foundation and shall not be in contact with or supporting any other shipping container or other structure.
2. The intermodal shipping container's top and bottom rails, corner castings, and columns or any portion thereof shall not be notched, cut, or removed in any manner.
3. The intermodal shipping container shall be erected in a level and horizontal position with the floor located at the bottom.

3115.8.5.2 Structural design. Where permitted by Section 3115.8.5.1, single unit, single-unit stand-alone intermodal shipping containers shall be designed using the following assumptions for the side walls and end walls:

1. The appropriate detailing requirements contained in Chapters 16 through 23.
2. Response modification coefficient, $R = 2$,
3. Over strength factor, $\Omega_0 = 2.5$,
4. Deflection amplification factor, $C_d = 2$, and
5. Limits on structural height, $h_m = 9.5$ feet (2900 mm).

3115.8.5.3 Allowable shear value. The allowable shear values for the intermodal shipping container side walls (longitudinal) and end walls (transverse) for wind design

and seismic design using the coefficients of Section 3115.8.5.2 shall be in accordance with Table 3115.8.5.3, provided that all of the following conditions are met:

1. The total linear length of all openings in any individual side walls or end walls shall be limited to not more than 50 percent of the length of that side walls or end walls, as shown in Figure 3115.8.5.3(1).
2. Any full height wall length, or portion thereof, less than 4 feet (305 mm) long shall not be considered as a portion of the lateral force-resisting system, as shown in Figure 3115.8.5.3(2).
3. All side walls or end walls used as part of the lateral force-resisting system shall have an existing or new boundary element on all sides to form a continuous load path, or paths, with adequate strength and stiffness to transfer all forces from the point of application to the final point of resistance, as shown in Figure 3115.8.5.3(3).
4. A maximum of one penetration not greater than a 6-inch (152 mm) diameter hole for conduits, pipes, tubes or vents, or not greater than 16 square inches (10 322mm²) for electrical boxes, is permitted for each individual 8 feet length (2438 mm) lateral force resisting wall. Penetrations located in walls that are not part of the wall lateral force resisting system shall not be limited in size or quantity. Existing intermodal shipping container's vents shall not be considered a penetration, as shown in Figure 3115.8.5.3(4).
5. End wall door or doors designated as part of the lateral force-resisting system shall be welded closed.

**TABLE 3115.8.5.3
ALLOWABLE SHEAR VALUES FOR INTERMODAL SHIPPING CONTAINER
SIDE WALLS AND END WALLS FOR WIND OR SEISMIC LOADING**

CONTAINER DESIGNATION ²	CONTAINER DIMENSION (Nominal Length)	CONTAINER DIMENSION (Nominal Height)	ALLOWABLE SHEAR VALUES (PLF) ^{1,3}	
			Side Wall	End Wall
1EEE	45 feet (13.7 M)	9.5 feet (2896 mm)	75	843
1EE		8.6 feet (2591 mm)		
1AAA	40 feet (12.2 M)	9.5 feet (2896 mm)	84	
1AA		8.5 feet (2592 mm)		
1A		8.0 feet (2438 mm)		
1AX		<8.0 feet (2483 mm)		
1BBB	30 feet (9.1 M)	9.5 feet (2896 mm)	112	
1BB		8.5 feet (2591 mm)		
1B		8.0 feet (2438 mm)		
1BX		<8.0 feet (2438 mm)		
1CC	20 feet (9.1 M)	8.5 feet (2591 mm)	168	
1C		8.0 feet (2438 mm)		
1CX		<8.0 feet (2438 mm)		

1. The allowable strength for the side walls and end walls of the intermodal shipping containers are derived from ISO 1496-1 and reduced by a factor of safety of 5.
2. Container designation type is derived from ISO 668.
3. Limitations of Sections 3115.8.5.1 and 3114.5.5.3 shall apply.

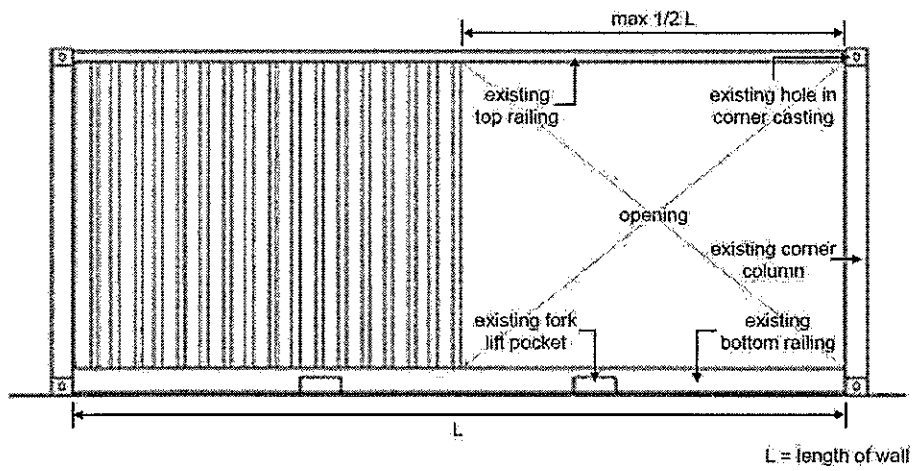

FIGURE 3115.8.5.3(1)
Bracing Unit Distribution – Maximum Linear Length

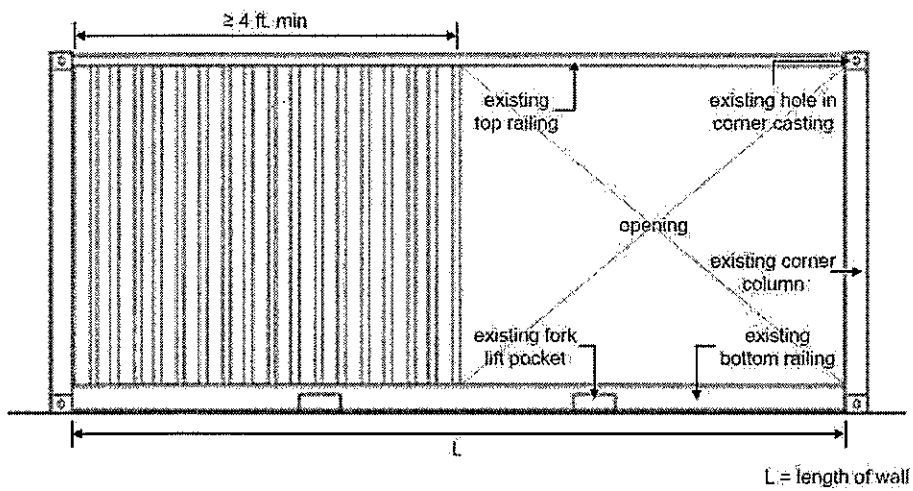

FIGURE 3115.8.5.3(2)
Bracing Unit Distribution – Minimum Linear Length

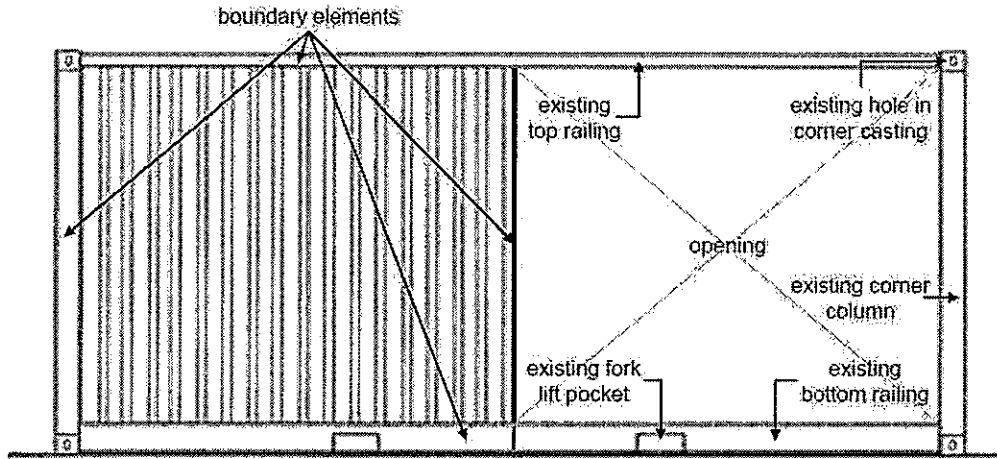

FIGURE 3115.8.5.3(3)
Bracing Unit Distribution – Boundary Elements

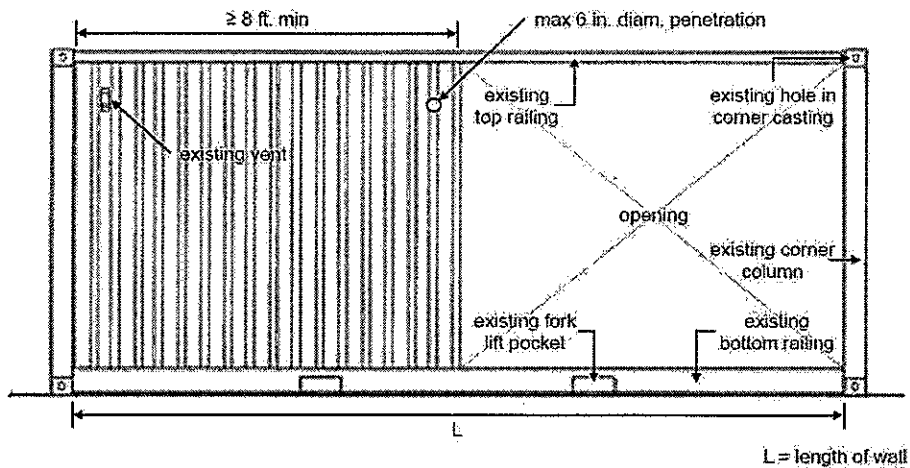

FIGURE 3115.8.5.3(4)
Bracing Unit Distribution – Penetrating Limitations

SECTION IA-94. Section 3202.1.2.1 of Volume IA of the Glendale Building and Safety Code, 2023, is hereby added to read as follows:

3202.1.2.1 Change of use/occupancy. Change of use or occupancy of existing encroachment into the public right-of-way shall comply with the following:

1. A structural review by a state licensed professional to evaluate the structure and its attachments (e.g. light fixtures or false ceilings) that they do not fall on the occupants if construction work or any other activities are performed above the occupied space within the public right-of-way.
2. The property owner shall enter into a Covenant and Agreement with the City to indemnify, defend and hold harmless the City of Glendale, its officers, agents, employees and representatives, from and against any and all liability, suits, actions, proceedings, judgments, claims, losses, liens, damages, injuries (whether in contract or in tort, including personal injury, accidental death or property damage, and regardless of whether the allegations are false, fraudulent or groundless), costs and expense (including attorney's fees litigation, arbitration, mediation, appeal expenses) as a condition of approval to change the use of the space within public right-of-way from storage use to other use.

SECTION IA-95. Section 3202.3.2 of Volume IA of the Glendale Building and Safety Code, 2023, is hereby amended to read as follows:

3202.3.2 Windows, architectural features and mechanical equipment. Where the vertical clearance above grade to projecting windows, architectural features or mechanical equipment is more than 8 feet (2438 mm), 1 inch (25 mm) of encroachment is permitted for each additional 1

inch (25 mm) of clearance above 8 feet (2438 mm), but the maximum encroachment shall be 4 feet (1219 mm).

SECTION IA-96. Section 3203 of Volume IA of the Glendale Building and Safety Code, 2023, is hereby added to read as follows:

SECTION 3203

PROJECTIONS INTO ALLEYS

3203.1 Projections into alleys. No part of any structure or any appendage thereto shall project into any alley.

Exception: Footings located at least 8 feet (2438 mm) below grade may project not more than 12" (305 mm).

SECTION IA-97. Section 3303.8 of Volume IA of the Glendale Building and Safety Code, 2023, is hereby added to read as follows:

3303.8 Storm water drainage and retention during demolition. Projects which disturb less than one acre of soil and are not part of a larger common plan of development which in total disturbs one acre or more, shall manage storm water drainage during construction in accordance with the California Green Building Standards Code (CALGreen), Chapter 4, Division 4.2.

SECTION IA-98. Section 3306.2 of Volume IA of the Glendale Building and Safety Code, 2023, is hereby amended to read as follows:

3306.2 Walkways. A walkway shall be provided for pedestrian travel in front of every construction and demolition site unless the applicable governing authority authorizes the sidewalk to be fenced or closed. Walkways shall be of sufficient width to accommodate the pedestrian traffic, but in no case shall they be less than 5 feet (1524 mm) in width. Walkways shall be provided with a durable walking surface. Walkways shall be accessible in accordance

with *Chapter 11A or 11B as applicable*, and shall be designed to support all imposed loads and in no case shall the design live load be less than 150 pounds per square foot (psf) (7.2 kN/m²).

SECTION IA-99. Section 3306.9.1 of Volume IA of the Glendale Building and Safety Code, 2023, is hereby added to read as follows:

3306.9.1 Shoring. The sidewalk and street shall be protected from caving and settlement by shoring conforming to the safety orders issued by the Division of Occupational Safety and Health, Department of Industrial Relations.

SECTION IA-100. Section 3306.10 of Volume IA of the Glendale Building and Safety Code, 2023, is hereby added to read as follows:

3306.10. Protection of sidewalk excavations. Permits must be secured from the director of public works in accordance with the provisions of the Glendale Municipal Code for making an excavation within a public street, sidewalk, parkway or public property. When any portion of a public sidewalk is to be excavated, the holder of the permit shall construct a substantial temporary walkway not less than five (5) feet (1524 mm) in width for pedestrian travel over the areas to be excavated or around the same.

SECTION IA-101. Section 3306.11 of Volume IA of the Glendale Building and Safety Code, 2023, is hereby added to read as follows:

3306.11. Protection of Obstructions. No person excavating, refilling or obstructing any public sidewalk, street, alley or roadway in the city shall fail or neglect to place barriers at each end and at all necessary places along any such excavations or obstructions to prevent accidents and no such person shall fail or neglect to display and maintain amber lights from sunset to sunrise at each end and at all necessary places along any such excavation or obstructions run across or substantially across any sidewalk, street, alley, or roadway, such amber lights at such places shall

be placed not more than five (5) feet (1524 mm) apart. If, in any case, the director of public works shall designate any particular locations for barriers or require additional light, such barriers or lights shall be placed and maintained at those locations designated. If any permittee fails to perform the duties herein before defined, the director of public works may cause the same to be performed, at the expense of the permittee, or if a deposit has been made pursuant to the Glendale Municipal Code, 1995, then the expense of such performance may be deducted therefrom to the extent said deposit is sufficient, and if insufficient, then the remaining amount may be charged against the permittee.

SECTION IA-102. Section 3308.3 of Volume IA of the Glendale Building and Safety Code, 2023, is hereby added to read as follows:

3308.3 Street Use Permits.

3308.3.1 Permits generally. No person shall use or occupy or obstruct any portion of any sidewalk, street, alley or roadway for storing materials for building purposes, for mixing concrete or mortar, or for any purpose incidental thereto, or for the construction of walkways, fences or canopies in accordance with the provisions of this code, unless a street use permit has been first obtained from the director of public works to do so, and at least one-half of the width of the sidewalk, or a width to be designated by the director of public works of the street, alley or roadway is at all times kept free and clear of all obstructions.

3308.3.2 Street use permit to be posted. The street use permit required by this Section 3308.3 shall at all times during such use, occupancy or obstruction, be conspicuously posted on or near the sidewalk, street, alley or roadway used, occupied or obstructed.

3308.3.3 Term of permit; removal of obstructions. Any permit required by this Section 3308.3 shall be granted for not longer than sixty (60) days. Upon completion of the work, all

such obstructions shall be removed, all damages caused thereby repaired and the street and sidewalk restored to their original condition to the satisfaction of the director of public works. If any permittee fails or neglects to so remove, repair and restore within three (3) days after being notified by the director of public works in person or by letter, the director of public works may cause such removal, repairs and restoration to be done at the expense of the permittee.

3308.3.4 Application for street use permits. All applications for street use permits required by this Section 3308.3 shall be in writing and made to the building and safety division and shall be in writing and shall be accompanied by a fee for services provided hereunder which shall be established or modified by resolution of the City Council. The schedule for such fees shall remain on file and be available in the office of the traffic and transportation administrator.

SECTION IA-103. Section 3308.4 of Volume 1A of the Glendale Building and Safety Code, 2023, is hereby added to read as follows:

3308.4 Mixing Mortar on Public Property. The mixing or handling of mortar, concrete or other material on public property, when authorized by the director of public works under a street use permit issued under Section 3308.3 of this Code, shall be done in a mechanical mixer or in a tight box in such a manner as to prevent dripping or splashing on public property.

SECTION IA-104. ~~Appendix F, RODENTPROOFING, of the California Building Code, 2022 edition, published and copyrighted by the International Code Council and California Building Standards Commission is hereby adopted into Volume 1A of the Glendale Building and Safety Code, 2023, by reference and by such reference is incorporated herein as if fully set forth.~~

SECTION IA-105. Appendix I, PATIO COVERS, of the California Building Code, 2022 edition, published and copyrighted by the International Code Council and the California Building Standards Commission is hereby adopted into Volume 1A of the Glendale Building and

Safety Code, 2023, by reference, as further amended herein, into the Glendale Building and Safety Code 2017, and by such reference, is incorporated herein as if fully set forth.

SECTION IA-106. Appendix I, Section I105.1 of Volume IA of the Glendale Building and Safety Code, 2023, is hereby amended to read as follows:

I105.1 Design loads. Patio covers shall be designed and constructed to sustain, within the stress limits of this code, all dead loads plus a minimum vertical live load of 10 pounds per square foot (0.48 IN/m²) except that snow loads shall be used where such snow loads exceed this minimum. Such patio covers shall be designed to resist the minimum wind and seismic loads set forth in this code. Solar energy systems shall not be installed on patio covers designed by this Section.

SECTION IA-107. Appendix J, GRADING, of the California Building Code, 2022 edition, published and copyrighted by the International Code Council, is hereby adopted into Volume IA of the Glendale Building and Safety Code, 2023, by reference, as further amended herein, into the Glendale Building and Safety Code, 2023, and by such reference, is incorporated herein as if fully set forth.

SECTION IA-108. Appendix J Section J101.1 of Volume IA of the Glendale Building and Safety Code, 2023, is hereby amended to read as follows:

J101.1 Scope. The provisions of this chapter apply to grading, excavation and earthwork construction, including fills and embankments and the control of grading site runoff, including erosion sediments and construction-related pollutants. Where conflicts occur between the technical requirements of this chapter and the geotechnical report, the more restrictive requirement shall govern.

SECTION IA-109. Appendix J Section J101.3 of Volume IA of the Glendale Building and Safety Code, 2023, is hereby added to read as follows:

J101.3 Hazards.

1. Whenever the building official determines that any land or any existing excavation or fill has, from any cause, become a menace to life or limb, or endangers public or private property, or adversely affects the safety, use or stability of public or private property, the owner or other person in legal control of the property concerned shall, upon receipt of a written notice thereof from the building official, correct such condition in accordance with the provisions of this appendix and the requirements and conditions set forth in the notice so as to eliminate such condition. The owner or other person in legal control of the property shall immediately comply with the provisions set forth in the notice and shall complete the work within 180 days from the date of the notice unless a shorter period of time for completion has been specified in the notice in which case the owner shall comply with the shorter period of time. Upon written application and good cause shown, the building official may approve the request for an extension of time to complete the work required by the notice.
2. If the above condition is not eliminated within the specified time period, the building official may file with the Office of the Los Angeles County Recorder a certificate stating that the property is deemed substandard and that the owner thereof has been so notified to correct the substandard condition. Said certificate shall specify the conditions creating the substandard classification.
3. When the above conditions have been corrected to the satisfaction of the building official, upon receiving a sixty-dollar fee from the owner or his agent, the building official shall

file with the Office of the Los Angeles County Recorder, within a reasonable period of time, a certificate specifying that the conditions creating the substandard classification have been corrected and that the property is no longer considered substandard.

SECTION IA-110. Appendix J Section J101.4 of Volume IA of the Glendale Building and Safety Code, 2023, is hereby added to read as follows:

J101.4 Safety precautions.

1. General.

- (a) If at any stage of work on an excavation or fill, the building official determines that the work has become or is likely to become dangerous to any person, or is likely to endanger any property, public or private, the building official shall be authorized to require safety precautions to be immediately taken by the property owner as a condition to continuing such permitted work or to require cessation thereof forthwith unless and until it is made safe and to amend the plans for such work.
- (b) Safety precautions may include, but shall not be limited to, specifying a flatter exposed slope or construction of additional drainage facilities, berms, terracing, compaction, cribbing, retaining walls or buttress fills, slough walls, desilting basins, check dams, benching, wire mesh and guniting, rock fences, revetments or diversion walls.
- (c) Upon the determination of the building official that such safety precautions during grading are necessary, the building official shall provide a notice and order to the permittee to implement same. After receiving such notice, oral or written, it is unlawful for the permittee or any person to proceed with such work contrary to such order.

2. Hillside Areas. For the purposes of this appendix, hillside areas shall include all property designated as “mountainous terrain” pursuant to Article 16.08.270 of the Glendale Municipal Code, 1995. Except as specifically excepted in this appendix, no person shall conduct any grading operation in hillside areas unless such operations are for building site development or another use for which the permittee has obtained an entitlement prior to applying for a grading permit.

Exception: Grading which is not connected with building site development may be conducted in hillside areas only when the applicant demonstrates to the satisfaction of the building official, that such work does all of the following: enhances the physical stabilization of the affected property; is not detrimental to public health, safety or welfare; and is in conformity with the approved master plan for the area, if such master plan exists. A tentative tract or division of land map shall not be required for such exempt grading.

3. Removal of Ground Cover.
 - (a) The existing vegetative ground cover of any watershed in any hillside area shall not be destroyed, removed or damaged except for routine maintenance pursuant to lawful grading, use or occupancy of the property or to clear hazardous vegetation near structures and roads in areas designated as Wildland Urban Interface Fire Areas (also known as High Fire Hazard Areas) pursuant to this code.
 - (b) Except for indigenous trees as regulated by Chapter 12.44 of the Glendale Municipal Code, 1995, and as that chapter may subsequently be amended, removal of trees and shrubbery may be permitted where such work will not cause erosion, slope failure, or will not unduly disturb the turf, sod or other existing vegetative ground cover.

Whenever such groundcover is removed or damaged pursuant to a validly issued grading permit, the permittee shall restore and maintain the affected area with an approved ground cover, or shall accomplish such other erosion control protection measures as may be approved by the building official. Such erosion control shall be completed within thirty days after cessation of the grading work or other work pursuant to a validly issued building permit.

4. **Maintenance of Protective Devices.** All devices used to protect hillside areas from erosion or landslide damage including, but not limited to, retaining walls, cribbing, terracing, surface and subsurface drainage structures, interceptor drains, check dams, and riprap shall be maintained in good condition and repair as approved by the building official at the time of completion of construction thereof.

SECTION IA-111. Appendix J Section J101.5 of Volume IA of the Glendale Building and Safety Code, 2023, is hereby added to read as follows:

J101.5 Protection of utilities. The owner and permittee of any property on which grading has been performed and that requires a grading permit under Section J103 shall be responsible for the prevention of damage to any public utilities or services.

SECTION IA-112. Appendix J Section J101.6 of Volume IA of the Glendale Building and Safety Code, 2023, is hereby added to read as follows:

J101.6 Protection of adjacent property. The owner and permittee of any property on which grading has been performed and that requires a grading permit under Section J103 is responsible for the prevention of damage to adjacent property and no person shall excavate on land sufficiently close to the property line to endanger any adjoining public street, sidewalk, alley, or other public or private property without supporting and protecting such property from settling,

cracking or other damage that might result. Special precautions approved by the building official shall be made to prevent imported or exported materials from being deposited on the adjacent public way and/or drainage courses.

SECTION IA-113. Appendix J Section J101.7 of Volume IA of the Glendale Building and Safety Code, 2023, is hereby added to read as follows:

J101.7 Storm water control measures. The owner and permittee of any property on which grading has been performed and that requires a grading permit under Section J103 shall put into effect and maintain all precautionary measures necessary to protect adjacent water courses and public or private property from damage by erosion, flooding, and deposition of mud, debris and construction-related pollutants originating from the site during, and after, grading and related construction activities. Furthermore, the owner and permittee shall be responsible for putting into effect and maintaining appropriate measures necessary to prevent any change in cross-lot surface drainage that may adversely affect any adjoining property as a result of grading and/or construction-related activities. Such measures to prevent any adverse cross-lot surface drainage effects on adjoining property shall be required whether shown on approved grading plans or not.

SECTION IA-114. Appendix J Section J101.8 of Volume IA of the Glendale Building and Safety Code, 2023, is hereby added to read as follows:

J101.8 Conditions of approval. In granting any permit under this code, the building official may include such conditions as may be reasonably necessary to prevent creation of a nuisance or hazard to public or private property. Such conditions may include, but shall not be limited to:

1. Improvement of any existing grading to comply with the standards of this code.
2. Requirements for fencing of excavations or fills which would otherwise be hazardous.

SECTION IA-115. Appendix J Section J101.9 of Volume IA of the Glendale Building and Safety Code, 2023, is hereby added to read as follows:

J101.9 Rules and regulations.

J101.9.1 Rules. The permissive provisions of this chapter shall not be presumed to waive any regulations imposed by other statutes or other ordinances of the State of California or the City of Glendale.

J101.9.2 Regulations. If two or more pertinent regulations are not identical, those regulations shall prevail which are more restrictive or which afford greater safety to life, limb, health, property or welfare. For the purposes of these regulations, grading permits shall be considered as building permits and shall be subject to the administrative provisions of this code, unless otherwise specifically provided for in this chapter.

SECTION IA-116. Appendix J Section J102 of Volume IA of the Glendale Building and Safety Code, 2023, is hereby amended to read as follows:

SECTION J102

DEFINITIONS

J102.1 Definitions. The following words and terms shall, for the purposes of this appendix, have the meanings shown herein. Refer to Chapter 2 of the California Building Code for general definitions.

BENCH. A relatively level step excavated into earth material on which fill is to be placed.

BEST MANAGEMENT PRATICE (BMP). A stormwater pollution mitigation measure that is required to be employed in order to comply with the requirements of the NPDES permit issued to the County of Los Angeles, and as that permit may be subsequently amended.

COMPACTION. The densification of a fill by mechanical means.

CUT. See “Excavation.”

DOWN DRAIN. A device for collecting water from a swale or ditch located on or above a slope, and safely delivering it to an approved drainage facility.

EROSION. The wearing away of the ground surface as a result of the movement of wind, water or ice.

EXCAVATION. The removal of earth material by artificial means, also referred to as a cut.

FILL. Deposition of earth materials by artificial means.

GRADE. The vertical location of the ground surface.

GRADE, EXISTING. The grade prior to grading.

GRADE, FINISHED. The grade of the site at the conclusion of all grading efforts.

GRADING. An excavation or fill or combination thereof.

KEY. A compacted fill placed in a trench excavated in earth material beneath the toe of a slope.

SLOPE. An inclined surface, the inclination of which is expressed as a ratio of horizontal distance to vertical distance.

SLOPE FAILURE means the slippage, instability, slide or loss of earth material from a slope for any reason. Class I slope failures involve bedrock. Class II slope failures involve soil above but not including bedrock. Class III slope failures involve only surficial problems with no involvement of bedrock.

STORM WATER POLLUTION PREVENTION PLAN. A site drawing with details, notes, and related documents that identify the measures proposed by the permittee to: (1) control erosion and prevent sediment and construction-related pollutants from being carried offsite by stormwater, and (2) prevent non-stormwater discharges from entering the storm drain system.

TERRACE. A relatively level step constructed in the face of a graded slope for drainage and maintenance purposes.

SECTION IA-117. Appendix J Section J103.1 of Volume IA of the Glendale Building and Safety Code, 2023, is hereby amended to read as follows:

J103.1 Permits required. Except as exempted in Section J103.2, no grading shall be performed without first having obtained a permit therefore from the building official. A grading permit does not include the construction of retaining walls or other structures. A separate permit shall be obtained for each site and may cover both excavations and fills. Any engineered grading as described in Appendix J Section J104 shall be performed by a contractor licensed by the State of California to perform the work described hereon. Regular grading less than 5,000 cubic yards may require a licensed contractor if the building official determines that special conditions or hazards exist.

SECTION IA-118. Appendix J Section J103.2 of Volume IA of the Glendale Building and Safety Code, 2023, is hereby amended to read as follows:

J103.2 Exemptions. A grading permit shall not be required for the following:

1. When approved by the building official, grading in an isolated, self-contained area, provided there is no danger to the public, and that such grading will not adversely affect adjoining properties.
2. Excavation for construction of a structure permitted under this code where the excavation is limited to within the volume of the proposed structure.
3. Cemetery graves.
4. Refuse disposal sites controlled by other regulations.
5. Excavations for wells, or trenches for utilities.

6. Mining, quarrying, excavating, processing or stockpiling rock, sand, aggregate or clay controlled by other regulations, provided such operations do not affect the lateral support of, or significantly increase stresses in, soil and adjoining properties.
7. Exploratory excavations performed under the direction of a registered soils engineer or engineering geologist. This shall not exempt grading of access roads or pads created for exploratory excavations. Exploratory excavations must not create a hazardous condition to adjacent properties or the public in accordance with Section J101.3. Exploratory excavations must be restored to existing conditions, unless approved by the building official.
8. An excavation that does not exceed 50 cubic yards (38.3 m³) and complies with one of the following conditions:
 - (1) is less than 2 feet (0.6 m) in depth.
 - (2) does not create a cut slope greater than 5 feet (1.5 m) measured vertically upward from the cut surface to the surface of the natural grade and is not steeper than 2 units horizontal to 1 unit vertical (50 percent slope).
9. A fill not intended to support a structure, that does not obstruct a drainage course and complies with one of the following conditions:
 - (a) is less than 1 foot (0.3 m) in depth and is placed on natural terrain with a slope flatter than 5 units horizontal to 1 unit vertical (20 percent slope).
 - (b) is less than 3 feet (0.9 m) in depth at its deepest point measured vertically upward from natural grade to the surface of the fill, does not exceed 50 cubic yards, and creates a fill slope no steeper than 2 units horizontal to 1 unit vertical (50 percent slope).

(c) is less than 5 feet (1.5 m) in depth at its deepest point measured vertically upward from natural grade to the surface of the fill, does not exceed 20 cubic yards, and creates a fill slope no steeper than 2 units horizontal to 1 unit vertical (50 percent slope).

Exemption from the permit requirements of this appendix shall not be deemed to grant authorization for any work to be done in any manner in violation of the provisions of this code or any other laws or ordinances of this jurisdiction.

EXCAVATIONS		FILLS - NOT INTENDED TO SUPPORT STRUCTURES - DO NOT OBSTRUCT A DRAINAGE COURSE	
AN EXCAVATION WHICH IS LESS THAN 2 FT IN DEPTH AND DOES NOT EXCEED 50CY		FILL PLACED ON NATURAL GRADE NOT STEEPER THAN 5:1 AND LESS THAN 1FT DEEP	
AN EXCAVATION WHICH CREATES A CUT SLOPE NOT GREATER THAN 5FT IN HEIGHT, NOT STEEPER THAN 2:1, AND DOES NOT EXCEED 50CY		FILL LESS THAN 3FT DEEP AT ITS DEEPEST POINT THAT DOES NOT EXCEED 50CY	
		FILL LESS THAN 5FT DEEP AT ITS DEEPEST POINT THAT DOES NOT EXCEED 20CY	

FIGURE J103.2

SECTION IA-119. Appendix J Section J103.3 of Volume IA of the Glendale Building and Safety Code, 2023, is hereby added to read as follows:

J103.3 Unpermitted grading. A person shall not own, use, occupy or maintain any site containing unpermitted grading. For the purposes of this code, unpermitted grading shall be defined as the following:

1. Grading that was performed, at any point in time, without the required permit(s) having first been obtained from the building official, pursuant to Section J103.1.

2. Grading that was permitted and the work was not completed pursuant to Section J105 and the grading permit has expired pursuant to Chapter 1 Division II Section [A] 105.5.

SECTION IA-120. Appendix J Section J103.4 of Volume IA of the Glendale Building and Safety Code, 2023, regarding grading fees, is hereby added to read as follows:

J103.4 Grading fees.

1. Fees for grading plan check and for grading permits shall be established or modified by resolution of the city council. The schedule of such fees shall remain on file and be available in the office of the building official. The building official shall, with the approval of the city manager, recommend changes to the council when the costs to provide grading plan check and grading inspection services make it appropriate.
2. The applicant shall pay a plan check fee prior to acceptance of grading plans and specifications for checking by the city. The plan check fee shall be based on the total volume of the excavation and fill, on the site. The grading plan check fee shall be recalculated each time the grading plan volume of excavation and fill exceeds the volume used to determine the original plan check fee, and the applicant shall pay the difference between the revised and original fee before the revised grading plans are accepted for review by the city. The original grading plan check fee includes the cost to the applicant for the original submittal plus two additional submittals of corrected grading plans and specifications. When required by the building official, the applicant shall pay a supplemental grading plan check fee in accordance with the fee resolution established by the city council.
3. Whenever the applicant submits a grading plan for plan check that is substantially different in design of the earthwork as compared to previously submitted grading plans,

the submittal shall be considered an original and a new grading plan check fee shall be determined and paid to the city as provided in this section.

4. The applicant shall pay a grading permit fee prior to the issuance of a grading permit by the city. The fee shall be based on the total volume of excavation and fill, on the site. If, during grading operations, the plans and specifications for the grading project are revised increasing the volume of excavation, fill, or a combination thereof above the volume that was used to determine the grading permit fee, the applicant shall pay to the city the difference between the original grading permit fee and the recalculated fee before work may resume under the grading permit.
5. Whenever grading operations are commenced without an approved grading permit, a penalty shall be added to all unpaid fees for grading plan check and grading permits. The penalty shall be three hundred percent of all fees due the city.

SECTION IA-121. Appendix J Section J103.5 of Volume IA of the Glendale Building and Safety Code, 2023, is hereby added to read as follows:

J103.5 Bonds and insurance.

J103.5.1 Bonds – General.

1. Whenever an application for a grading permit is filed for the excavation or fill of one hundred cubic yards (76 m³) or more in hillside areas and five hundred cubic yards (382 m³) or more in other areas, the nature of the work regulated by this chapter is such that if left incomplete it will create a hazard to human life or endanger adjoining property, or property at a higher or lower level, or any street or street improvement or any other public property, the building official may, before issuing the grading permit, require the applicant to guarantee faithful performance and payment of labor and material in an

amount determined by the building official, not less than fifty percent nor more than one hundred percent of the total estimated cost of work, including corrective work necessary to remove and eliminate geologic hazards by one of the methods provided by this section.

2. An additional cash deposit may be required by the building official in the form of a cash bond sufficient to cover the cost of site cleanup and debris removal if determined by the building official that it is warranted.
3. Where grading is required on property adjacent to the grading site under permit to complete a project satisfactorily, the owner of such adjacent property need not provide additional performance bond if the original is of sufficient amount to include such additional grading.
4. Each bond and agreement for grading shall be effective upon the date of filing of application and shall remain in effect until the work authorized by the grading permit is completed and approved by the building official.
5. Installment refunds. When a substantial portion of the required grading work has been completed to the satisfaction of the building official, and when the completion of the remaining grading work, site development or planting is delayed, the building official may accept the completed portion of the grading work and consent to the proportionate reduction of the bond to an amount estimated to be adequate to ensure completion of the grading work, site development or planting remaining to be performed. Only one such reduction shall be considered for each bond posted.

J103.5.2 Performance bonds.

1. A guarantee of faithful performance for grading and improvement projects, when required by this chapter, shall be provided by one of the following methods:

- a. Surety bond. In the case the amount determined by the building official is in excess of \$10,000, a bond shall be executed by the applicant, as principal, and a corporate surety authorized to do business in the state of California, as surety, in a form furnished by the building official and approved by the city attorney;
- b. Cash bond. A cash deposit with the city;
- c. Instrument of credit and agreement. An instrument or instruments of credit from one or more financial institutions subject to regulation by the state or federal government pledging that the funds necessary to meet the performance are on deposit and guaranteed for payment and an agreement that the funds designated by the instrument shall become trust funds for the purpose of and in an amount determined by the building official not less than fifty percent nor more than one hundred percent of the total estimated cost of the work, including corrective work necessary to remove and eliminate the agreement shall first be approved by the city attorney.

J103.5.3 Performance bond defaults.

- A. Whenever the building official shall find that a default has occurred in the performance of any term or condition of any grading or construction permit, written notice of the fact of default thereof shall be given to the principal and to the corporate surety, financial institution or the depositor, stating the work to be done, and the period of time deemed by the building official to be reasonably necessary for the completion of such work. Thirty days after the receipt of such notice the principal or the surety shall perform or cause the required work to be performed by commencing and diligently prosecuting such work to its completion; but if they or either or both of them should fail to commence such work

within the thirty days or having so commenced such work fail, neglect or refuse to proceed diligently to complete the same within the time so specified in such notice, then the city may enter such premises and do such work and the cost and expense of so doing the work so specified shall be the obligation of the principal and such surety and shall be a part of the terms of the performance bond in consideration of the issuance of the grading permit.

- B. If a cash bond has been posted, notice of default shall be given to the principal, and if such principal fails to cause the required work to be resumed as set forth in such notice within thirty days after receipt thereof, the building official shall proceed without delay and further notice or proceedings whatsoever to use the cash deposited, or any portion thereof, and cause the required work to be completed by such mode as the building official deems convenient. The balance of such cash deposit, if any, shall upon the completion of the work be returned to the depositor or the depositor's successor or assigns after deducting ten percent thereof.
- C. If an instrument of credit is used to guarantee performance, notice of default shall be given to the principal and to the financial institution issuing such instrument of credit, and if such principal fails to cause the required work to be resumed as set forth in such notice within thirty days after receipt thereof, the building official shall make a demand upon the financial institution for the payment of the estimated costs from the trust fund held by such financial institution pursuant to the agreement. Upon receipt of such sum, the building official shall proceed without delay and without further notice or proceedings whatsoever to use such sum, or any portion thereof, and cause the required work to be completed by such made as the building official deems convenient. The

balance of such cash deposit, if any, shall upon the completion of the work be returned to the financial institution, its successors or assigns, after deducting ten percent thereof; but if such institution fails or refuses to pay over such sum then the building official shall look to such institution for the costs and expense of such work, and the contractual liability of such institution shall be a term or condition of its agreement.

J103.5.4 Contractor’s grading insurance – work done adjacent to public property.

Before issuing a grading permit for work being done adjacent to public property, the building official may require that the applicant, or his/her contractor, file a certificate and endorsement evidencing liability insurance satisfactory to the city attorney or risk manager. If required, such insurance shall provide coverage for damage to the city’s property and for the city’s liability and defense of claims for damages and suits for personal bodily injury and property damage, including but not limited to damage to the city arising out of the deposition, runoff or washing of materials, or any other damage to city property, which may arise from or out of the performance of the work, whether such performance be by such contractor, its subcontractors or any other person directly or indirectly employed by such contractor or subcontractors.

SECTION IA-122. Appendix J Section J104.2 of Volume IA of the Glendale Building and Safety Code, 2023, is hereby amended to read as follows:

J104.2 Grading plan requirements. In addition to the provisions of Section 107, Chapter 1, Division II a grading plan shall show the existing grade and finished grade in contour intervals of sufficient clarity to indicate the nature and extent of the work and show in detail that it complies with the requirements of this code. The plans shall show the existing grade on adjoining properties in sufficient detail to identify how grade changes will conform to the requirements of this code.

SECTION IA-123. Appendix J Section J104.2.1 of Volume IA of the Glendale Building and Safety Code, 2023, is hereby added to read as follows:

J104.2.1 Grading Designation. Grading in mountainous terrain, as identified in Section 16.08.270 of the Glendale Municipal Code, 1995, and all grading in excess of 5,000 cubic yards (3,825 m³) shall be performed in accordance with the approved grading plan prepared by a registered civil engineer, and shall be designated as “engineered grading.” Grading involving less than 5,000 cubic yards (3,825 m³) and not located in an area of mountainous terrain shall be designated as “regular grading” unless the permittee chooses to have the grading performed as engineered grading, or the building official determines that special conditions or unusual hazards exist, in which case grading shall conform to the requirements for engineered grading.

SECTION IA-124. Appendix J Section J104.2.2 of Volume IA of the Glendale Building and Safety Code, 2023, is hereby added to read as follows:

J104.2.2 Regular grading requirements. In addition to the provisions of Section 106, and Section 104.2, Chapter 1, Division II, an application for a regular grading permit shall be accompanied by two sets of plans in sufficient clarity to indicate the nature and extent of the work. The plans shall give the location of the work, the name of the owner, and the name of the person who prepared the plan. If the slope of the grade exceeds 3 units horizontal to 1 unit vertical or as required by the building official, the plans and specifications shall be prepared and signed by an individual licensed by the state to prepare such plans or specifications. The plan shall include the following information:

1. General vicinity of the proposed site.
2. Limits and depths of cut and fill.

3. Location of any buildings or structures where work is to be performed, and the location of any buildings or structures within 15 feet (4.6 m) of the proposed grading.
4. Contours, flow areas, elevations, or slopes which define existing and proposed drainage patterns.
5. Storm water provisions in accordance with the requirements of Appendix J Section J111.
6. Location of existing and proposed utilities, drainage facilities, and recorded public and private easements and use restricted use areas.
7. Location of all Special Flood Hazard Areas as designated and defined in Title 44, Code of Federal Regulations.

SECTION IA-125. Appendix J Section J104.2.3 of Volume IA of the Glendale Building and Safety Code, 2023, is hereby added to read as follows:

J104.2.3 Engineered grading requirements. In addition to the provisions of Chapter 1 Division II, Section 107 and Appendix J Section J104.2, an application for an engineered grading permit shall be accompanied by three sets of plans and specifications, and supporting data consisting of a soils engineering report and engineering geology report. The plans and specifications shall be prepared and signed by an individual licensed by the state to prepare such plans or specifications when required by the building official. Specifications shall contain information covering construction and material requirements. Plans shall be drawn to scale upon substantial paper or cloth and shall be of sufficient clarity to indicate the nature and extent of the work proposed and show in detail that it will conform to the provisions of this code and all relevant laws, ordinances, rules, and regulations. The first sheet of each set of plans shall give location of the work, the name and address of the owner, and the person by whom they were prepared.

The plans shall include, but shall not be limited to, the following information:

1. General vicinity of the proposed site.
2. Property limits and accurate contours of existing ground and details of terrain and area drainage.
3. Limiting dimensions, elevations, or finish contours to be achieved by the grading, proposed drainage channels, and related construction.
4. Detailed plans of all surface and subsurface drainage devices, walls, cribbing, dams and other protective devices to be constructed with, or as a part of, the proposed work. A map showing the drainage area and the estimated runoff of the area served by any drains shall also be provided.
5. Location of any existing or proposed buildings or structures on the property where the work is to be performed and the location of any buildings or structures on land of adjacent owners that are within 15 feet (4.6 m) of the property or that may be affected by the proposed grading operations.
6. Recommendations in the geotechnical engineering report and the engineering geology report shall be incorporated into the grading plans or specifications. When approved by the building official, specific recommendations contained in the geotechnical engineering report and the engineering geology report, that are applicable to grading, may be included by reference.
7. The dates of the geotechnical engineering and engineering geology reports together with the names, addresses, and telephone numbers of the firms or individuals who prepared the reports.

8. A statement of the earthwork quantities of materials to be excavated and/or filled.
Earthwork quantities shall include quantities for geotechnical and geological remediation. In addition, a statement of material to be imported or exported from the site.
9. A statement of the estimated starting and completion dates for work covered by the permit.
10. A statement signed by the owner acknowledging that a field engineer, geotechnical engineer and engineering geologist, when appropriate, will be employed to perform the services required by this code, whenever approval of the plans and issuance of the permit are to be based on the condition that such professional persons be so employed. These acknowledgements shall be on a form furnished by the building official.
11. Storm water provisions are required to be shown on the grading plan in accordance with Appendix J Section J111.
12. A drainage plan for that portion of a lot or parcel to be utilized as a building site (building pad), including elevation of floors with respect to finish site grade and locations of existing and proposed stoops, slabs, fences or other features that may affect drainage.
13. Location and type of any existing or proposed private sewage disposal system.
14. Location of existing and proposed utilities, drainage facilities, and recorded public and private easements.
15. Location of all recorded floodways.
16. Location of all Special Flood Hazard Areas as designated and defined in Title 44, Code of Federal Regulations.

SECTION IA-126. Appendix J Section J104.3 of Volume IA of the Glendale Building and Safety Code, 2023, is hereby amended to read as follows:

J104.3 Geotechnical engineering and engineering geology report.

Geotechnical reports shall be required for all projects requiring a grading permit unless such report is determined unnecessary by the building official. Whenever a geotechnical report is required, the building official may require that such report be reviewed by a licensed professional and the cost associated with such review shall be required to be paid by the applicant.

The geotechnical engineering report required by Appendix J Section J104.2.3 shall include data regarding the nature, distribution and strength of existing soils, conclusions and recommendations for grading procedures and design criteria for corrective measures, including buttress fills, when necessary, and opinion on adequacy for the intended use of sites to be developed by the proposed grading as affected by geotechnical engineering factors, including the stability of slopes. All reports shall conform with the requirements of this code and shall be subject to review by the building official. Supplemental reports and data may be required as the building official may deem necessary. Recommendations included in the reports and approved by the building official shall be incorporated in the grading plan or specifications. The engineering geology report required by Appendix J Section J104.2.3 shall include an adequate description of the geology of the site, conclusions and recommendations regarding the effect of geologic conditions on the proposed development, and opinion on the adequacy for the intended use of sites to be developed by the proposed grading, as affected by geologic factors. The engineering geology report shall include a geologic map and cross sections utilizing the most recent grading plan as a base.

All reports shall conform with the requirements of this code and shall be subject to review by the building official. Supplemental reports and data may be required as the building official may deem necessary. Recommendations included in the reports and approved by the building official shall be incorporated in the grading plan or specifications.

Exception: A geotechnical engineering or engineering geology report is not required where the building official determines that the nature of the work applied for is such that a report is not necessary.

SECTION IA-127. Appendix J Section J104.4 of Volume IA of the Glendale Building and Safety Code, 2023, is hereby amended to read as follows:

J104.4 Liquefaction study. For sites with mapped maximum considered earthquake spectral response accelerations at short periods (S_s) greater than 0.5g as determined by Section 1613, a study of the liquefaction potential of the site shall be provided, and the recommendations incorporated in the plans. A geotechnical investigation will be required when the proposed work is a “Project” as defined in California Public Resources Code Section 2693, and is located in an area designated as a “Seismic Hazard Zone” as defined in California Code of Regulations Section 3722 on Seismic Hazard Zone Maps issued by the State Geologist under Public Resources Code Section 2696.

Exception: A liquefaction study is not required where the building official determines from established local data that the liquefaction potential is low.

SECTION IA-128. Appendix J Section J104.5 of Volume IA of the Glendale Building and Safety Code, 2023, is hereby added to read as follows:

J104.5 Slope failure reports. In addition to any other requirements set forth in this Appendix J, for Class I slope failures, the permit applicant shall submit to the building official a combined

geotechnical engineering and engineering geology report to address its cause and provide recommended repair methods. For Class II slope failures, the permit applicant shall submit to the building official an engineering geology report to address its cause and provide recommended repair methods. For Class III slope failure, unless there exist other conditions which, in the opinion of the building official, require the submission of geotechnical engineering or engineering geology reports, the permit applicant shall not be required to submit such reports.

SECTION IA-129. Appendix J Section J104.6 of Volume IA of the Glendale Building and Safety Code, 2023, is hereby added to read as follows:

J104.6 Permit issuance.

1. The issuance of a grading permit shall constitute an authorization to do only that work which is described or illustrated on the application for the permit or on the grading plans and specifications approved by the building official at the time of issuance.
2. Jurisdiction of other agencies. Permits issued under the requirements of this chapter shall not relieve the owner of responsibility for securing required permits for work to be accomplished which is regulated by any other code, department or division of the governing agency.
3. Tract map requirements. No grading permit shall be issued for import or export of earth materials to or from, and no grading shall be conducted on, any unimproved acreage in hillside areas unless a tentative tract map has been approved by the council or a parcel map has been approved by the planning commission or an affidavit is filed declaring the grading shall not be for subdivision purposes.
4. Conditions of permit. The building official, upon recommendation of the city traffic and transportation administrator, may impose such regulations with respect to access routes to

and from grading sites in hillside areas as the building official shall determine are required in the interest of safety precautions involving pedestrian or vehicular traffic.

5. No permit shall be issued for the export or import of earth materials to or from a grading site in hillside areas involving ingress or egress on streets having less than 30 feet (9 m) in usable width, except upon all of the following conditions:

- a. The size or type of hauling equipment shall be limited in accordance with the width and conditions of the street;
- b. Traffic-control devices, including flag officers, signs and markers shall be utilized at appropriate places along the designated routes of access to such sites;
- c. Temporary no-parking restrictions shall be imposed with the approval of the city traffic and transportation administrator along such routes when determined necessary;
- d. No person shall excavate or fill so as to cause falling rocks, soil or debris in any form to fall, slide or flow onto adjoining properties or public ways;
- e. In granting a permit under this chapter, the building official shall attach such conditions as may be necessary to prevent creation of hazard to public or private property;
- f. In no event shall any export or import of earth materials to or from a grading site over dedicated and improved streets in hillside areas be undertaken or conducted except by use of equipment which complies in all respects with the state Vehicle Code;
- g. All vehicle loads shall be trimmed and watered, or otherwise secured so as to prevent spillage from the equipment;

SECTION IA-131. Appendix J Section J105.4 of Volume IA of the Glendale Building and Safety Code, 2023, is hereby added to read as follows:

J105.4 Geotechnical engineer. The geotechnical engineer shall provide professional inspection within such engineer's area of technical specialty, which shall include observation during grading and testing for required compaction. The geotechnical engineer shall provide sufficient observation during the preparation of the natural ground and placement and compaction of the fill to verify that such work is being performed in accordance with the conditions of the approved plan and the appropriate requirements of this code. Revised recommendations related to conditions differing from the approved geotechnical engineering and engineering geology reports shall be submitted to the permittee, the building official and the field engineer.

SECTION IA-132. Appendix J Section J105.5 of Volume IA of the Glendale Building and Safety Code, 2023, is hereby added to read as follows:

J105.5 Engineering geologist. The engineering geologist shall provide professional inspection within such engineer's area of technical specialty, which shall include professional inspection of the bedrock excavation to determine if conditions encountered are in conformance with the approved report. Revised recommendations relating to conditions differing from the approved engineering geology report shall be submitted to the geotechnical engineer.

SECTION IA-133. Appendix J Section J105.6 of Volume IA of the Glendale Building and Safety Code, 2023, is hereby added to read as follows:

J105.6 Permittee. The permittee shall be responsible for the work to be performed in accordance with the approved plans and specifications and in conformance with the provisions of this code, and the permittee shall engage project consultants, if required, to provide professional inspections on a timely basis. The permittee shall act as a coordinator between the project

consultants, the contractor and the building official. In the event of changed conditions, the permittee shall be responsible for informing the building official of such change and shall provide revised plans for approval.

SECTION IA-134. Appendix J Section J105.7 of Volume IA of the Glendale Building and Safety Code, 2023, is hereby added to read as follows:

J105.7 Building official. The building official shall inspect the project site at the following various stages of work, as the building official deems necessary, to determine that adequate control is being exercised by the project consultants:

Pre-grade. Before any construction or grading activities occur at the site. Permittee shall schedule a pre-grade inspection with the building official. The permittee is responsible for coordinating that all project consultants are present at the pre-grade inspection.

Initial. When the site has been cleared of vegetation and unapproved fill and it has been scarified, benched or otherwise prepared for fill. No fill shall have been placed prior to this inspection.

Rough. When approximate initial elevations have been established; drainage terraces, swales and other drainage devices necessary for the protection of the building site(s) from flooding are installed; berms are installed at the top of the slopes; and the statements required by Section J105.12 have been received.

Final. When grading has been completed; all drainage devices necessary to drain the building pad(s) are installed; slope planting is established; irrigation systems are installed; and the as-built plans and required statements and reports have been submitted.

SECTION IA-135. Appendix J Section J105.8 of Volume IA of the Glendale Building and Safety Code, 2023, is hereby added to read as follows:

J105.8 Notification of noncompliance. If, in the course of fulfilling their respective duties under this chapter, the field engineer, the geotechnical engineer or the engineering geologist finds that the work is not being done in conformance with this chapter or the approved grading plans, the discrepancies and corrective measures which should be taken shall be reported immediately in writing to the permittee and the building official.

SECTION IA-136. Appendix J Section J105.9 of Volume IA of the Glendale Building and Safety Code, 2023, is hereby added to read as follows:

J105.9 Transfer of responsibility. If the field engineer, the geotechnical engineer or the engineering geologist of record is changed during grading, the work shall be stopped until the replacement has agreed in writing to accept their responsibility within the area of technical competency for approval upon completion of the work. It shall be the duty of the permittee to notify the building official in writing of such change prior to the recommencement of such grading.

SECTION IA-137. Appendix J Section J105.10 of Volume IA of the Glendale Building and Safety Code, 2023, is hereby added to read as follows:

J105.10 Non-inspected grading. No person shall own, use, occupy or maintain any non-inspected grading. For the purposes of this code, non-inspected grading shall be defined as any grading for which a grading permit was first obtained, pursuant to Appendix J Section J103, but which has progressed beyond any point requiring inspection and approval by the building official without such inspection and approval having been obtained.

SECTION IA-138. Appendix J Section J105.11 of Volume IA of the Glendale Building and Safety Code, 2023, is hereby added to read as follows:

J105.11 Routine field inspections and reports. Unless waived by the building official, routine inspection reports shall be provided by the field engineer for all engineered grading projects.

The field engineer shall file these reports with the building official as follows:

1. Bi-weekly during all times when grading of 400 cubic yards or more per week is occurring on the site;
2. Monthly, at all other time; and
3. At any time when requested in writing by the building official.

Such reports shall certify to the building official that the field engineer has inspected the grading site and related activities and has found them in compliance with the approved grading plans, the building code, grading permit conditions, and other applicable ordinances and requirements. The reports shall contain all required information in a standard “Report of Grading Activities” form which shall be provided by the building official.

SECTION IA-139. Appendix J Section J105.12 of Volume IA of the Glendale Building and Safety Code, 2023, is hereby added to read as follows:

J105.12 Completion of work. Upon completion of the rough grading work and at the final completion of the work, the following reports and drawings and supplements thereto are required for engineered grading or when professional inspection is required by the building official:

1. An “as-built” grading plan prepared by the field engineer to provide such services in accordance with Appendix J Section J105.3 showing all plan revisions as approved by the building official. This shall include original ground surface elevations, as-built ground elevations, lot drainage patterns, and the locations and elevations of surface drainage facilities and the outlets of subsurface drains. As-built locations, elevations and details of subsurface drains shall be shown as reported by the geotechnical

engineer. The field engineer shall state in a report, to the building official that to the best of their knowledge, the work within the area of responsibility was done in accordance with the final approved grading plan.

2. A report prepared by the geotechnical engineer retained to provide such services in accordance with Appendix J Section J105.5, including locations and elevations of field density tests, summaries of field and laboratory tests, other substantiating data, and comments on any changes made during grading and their effect on the recommendations made in the approved geotechnical engineering investigation report. Geotechnical engineer shall submit a statement that, to the best of their knowledge, the work within their area of responsibility is in accordance with the approved geotechnical engineering report and applicable provisions of this chapter. The report shall contain a finding regarding the safety of the completed grading and any proposed structures against hazard from landslide, settlement or slippage.
3. A report prepared by the engineering geologist retained to provide such services in accordance with Appendix J Section J105.6, including a final description of the geology of the site and any new information disclosed during the grading and the effect of same on recommendations incorporated in the approved grading plan. Engineering geologists shall submit a statement that, to the best of their knowledge, the work within their area of responsibility is in accordance with the approved engineering geologist report and applicable provisions of this chapter. The report shall contain a finding regarding the safety of the completed grading and any proposed structures against hazard from landslide, settlement, or slippage. The report

must contain a final as-built geologic map and cross-sections depicting all the information collected prior to and during grading.

4. The grading contractor shall submit in a form prescribed by the building official a statement of conformance to said as-built plan and the specifications.

SECTION IA-140. Appendix J Section J105.13 of Volume IA of the Glendale Building and Safety Code, 2023, is hereby added to read as follows:

J105.13 Notification of completion. The permittee shall notify the building official when the grading operation is ready for final inspection. Final approval shall not be given until all work, including installation of all drainage facilities and their protective devices, and all erosion control measures have been completed in accordance with the final approved grading plan, and the required reports have been submitted and approved.

SECTION IA-141. Appendix J Section J105.14 of Volume IA of the Glendale Building and Safety Code, 2023, is hereby added to read as follows:

J105.14 Change of ownership. Unless waived by the building official, when a grading permit has been issued on a site and the owner sells the property prior to final grading approval, the new property owner shall be required to obtain a new grading permit.

SECTION IA-142. Appendix J Section J106.1 of Volume IA of the Glendale Building and Safety Code, 2023, is hereby amended to read as follows:

J106.1 Maximum cut slope. The slope of cut surfaces shall be no steeper than is safe for the intended use, and shall be not more than 1 unit vertical in 2 units horizontal (50-percent slope) unless the applicant furnishes a geotechnical engineering or an engineering geology report, or both justifying a steeper slope. Reports must indicate that site was investigated and give an opinion that a cut at a steeper slope will be stable and not create a hazard to public or private

property in conformance with the requirements of Appendix J Section J104.2.3. The building official may require the excavation to be made with a cut face flatter in slope than 1 unit vertical to 2 units horizontal if the building official finds it necessary for stability and safety.

Exceptions:

1. A cut surface may be at a slope of 1.5 units horizontal to 1 unit vertical (67 percent slope) provided that all the following are met:
 - 1.1 It is not intended to support structures or surcharges.
 - 1.2 It is adequately protected against erosion.
 - 1.3 It is no more than 8 feet (2438 mm) in height.
 - 1.4 It is approved by the building code official
 - 1.5 Ground water is not encountered.
2. A cut surface in bedrock shall be permitted to be at a slope of 1 unit horizontal to 1 unit vertical (100 percent slope).

SECTION IA-143. Appendix J Section J106.3 of Volume IA of the Glendale Building and Safety Code, 2023, is hereby added to read as follows:

J106.2 Drainage. Drainage, including drainage terraces and overflow protection, shall be provided as required by Appendix J Section J109.

SECTION IA-144. Appendix J Section J107.1 of Volume IA of the Glendale Building and Safety Code, 2023, is hereby amended to read as follows:

J107.1 General. Unless otherwise recommended in the geotechnical report, fills shall comply with the provisions of this section. In the absence of an approved geotechnical engineering report and if approved by the building official, these provisions may be waived for minor fills not intended to support structures.

SECTION IA-145. Appendix J Section J107.2 of Volume IA of the Glendale Building and Safety Code, 2023, is hereby amended to read as follows:

J107.2 Surface preparation. Fill slopes shall not be constructed on natural slopes steeper than 2 units horizontal to 1 unit vertical (50 percent slope). The ground surface shall be prepared to receive fill by removing vegetation, topsoil and other unsuitable materials, and scarifying the ground to provide a bond with the fill material. Except where recommended by the geotechnical engineer or engineering geologist as not being necessary, subdrains shall be provided under all fills placed in natural drainage courses and in other locations where seepage is evident. Such sub-drainage systems shall be of a material and design approved by the geotechnical engineer and acceptable to the building official. The geotechnical engineer shall provide continuous inspection during the process of subdrain installations. The location of the subdrains shall be shown on a plan by the geotechnical engineer. Excavations for the subdrains shall be inspected by the engineering geologist when such subdrains are included in the recommendations of the engineering geologist.

SECTION IA-146. Appendix J Section J107.3 of Volume IA of the Glendale Building and Safety Code, 2023, is hereby amended to read as follows:

J107.3 Benching. Where existing grade is at a slope steeper than 1 unit vertical to 5 units horizontal (20 percent slope) and the depth of the fill exceeds 5 feet (1524 mm) benching shall be provided into sound bedrock or other competent material as determined by the geotechnical engineer. The ground preparation shall be in accordance with Figure J107.3 or as determined by the geotechnical engineer. When fill is to be placed over a cut, a key shall be provided which is at least 10 feet (3048 mm) in width and 2 feet (610 mm) in depth. The area beyond the toe of fill shall be sloped for sheet flow or a paved drain shall be provided. The cut shall be made before

placing the fill and the geotechnical engineer or engineering geologist or both shall accept the cut as suitable for the foundation and placement of fill material.

SECTION IA-147. Appendix J Section J107.6 of Volume IA of the Glendale Building and Safety Code, 2023, is hereby amended to read as follows:

J107.6 Maximum slope. The slope of fill surfaces shall be no steeper than is safe for the intended use. Fill slopes steeper than 1 unit vertical-to 2 units horizontal (50- percent slope) shall be justified by a geotechnical engineering report conforming with the requirements of Appendix J Section J104.2.3, stating that the site has been investigated and giving an opinion that a fill at a steeper slope will be stable and not create a hazard to public or private property. Substantiating calculations and supporting data may be required where the building official determines that such information is necessary to verify the stability and safety of the proposed slope. The building official may require the fill slope be constructed with a face flatter in slope than 1 unit vertical to 2 units horizontal (50 percent slope) if the building official finds it necessary for stability and safety.

SECTION IA-148. Appendix J Section J107.7 of Volume IA of the Glendale Building and Safety Code, 2023, is hereby added to read as follows:

J107.7 Slopes to receive fill. Where fill is to be placed above the top of an existing slope steeper than 3 units horizontal to 1 unit vertical (33 percent slope), the toe of the fill shall be set back from the top edge of the slope a minimum distance of 6 feet (1.8 m) measured horizontally or such other distance as may be specifically recommended by a geotechnical engineer or engineering geologist and approved by the building official.

SECTION IA-149. Appendix J Section J107.8 of Volume IA of the Glendale Building and Safety Code, 2023, is hereby added to read as follows:

J107.8 Inspection of fill. For engineered grading, the geotechnical engineer shall provide sufficient inspections during the preparation of the natural ground and the placement and compaction of the fill ensuring that the work is being performed in accordance with the conditions of plan approval and the appropriate requirements of this chapter. In addition to the above, the geotechnical engineer shall be present during the entire fill placement and compaction of fills that will exceed a vertical height or depth of 30 feet (9.1 m) or result in a slope surface steeper than 2 units horizontal to 1 unit vertical (50 percent slope).

SECTION IA-150. Appendix J Section J107.9 of Volume IA of the Glendale Building and Safety Code, 2023, is hereby added to read as follows:

J107.9 Testing of fills. Sufficient tests of the fill soils shall be made to determine the density and to verify compliance of the soil properties with the design requirements. This includes soil types and shear strengths in accordance with Referenced Standards Section J112.

SECTION IA-151. Appendix J Section J108 of Volume IA of the Glendale Building and Safety Code, 2023, is hereby amended to read as follows:

SECTION J108

SETBACKS AND RETAINING WALLS

J108.1 General. Cut and fill slopes shall be set back from the property lines in accordance with this section. Setback dimensions shall be measured perpendicular to the property line and shall be as shown in Figure J108.1, unless substantiating data is submitted justifying reduced setbacks and is recommended by a geotechnical engineering and engineering geology report approved by the building official.

J108.2 Top of slope. The setback at the top of a cut slope shall not be less than that shown in Figure J108.1, or than is required to accommodate any required interceptor drains, whichever is

greater. For graded slopes the grading design must be such that the property line between adjacent lots will be at the apex of the berm at the top of the slope. Property lines between adjacent lots shall not be located on a graded slope steeper than 5 units horizontal to 1 unit vertical (20 percent slope).

J108.3 Slope protection. Where required to protect adjacent properties at the toe of a slope from adverse effects of the grading, additional protection, approved by the building official, shall be included. Such protection may include but shall not be limited to:

1. Setbacks greater than those required by Figure J108.1.
2. Provisions for retaining walls or similar construction.
3. Erosion protection of the fill slopes.
4. Provision for the control of surface waters.

J108.4 Alternate setbacks. The building official may approve alternate setbacks. The building official may require an investigation and recommendation by a qualified geotechnical engineer or engineering geologist to demonstrate that the intent of this section has been satisfied.

J108.5 Retaining walls and crib walls.

1. All structures which are intended to retain earth material, shall be fully detailed, appropriately engineered, and where required by the building official be incorporated into a grading plan. Such grading plan shall be reviewed by the building official, or his or her designee, and must be approved prior to issuance of a building permit for any retaining walls on the site.
2. When required by the building official, grading permit applicants shall have grading plans prepared and reviewed by a qualified geologist, or a geotechnical engineer, or a combination thereof. All features of the grading plan must be included in such review,

and a recommendation shall be submitted by such qualified individual regarding the type of retaining wall system(s) to be used. Any recommendation to utilize a particular type of earth retention system shall be based on soil strength parameters for the subject property and detailed slope stability analysis.

3. Cantilever retaining walls must be designed to provide a minimum factor of safety against overturning of 1.5 and a minimum factor of safety against sliding of 1.5. The building official shall have the authority to require a higher factor of safety against overturning or sliding, or both if he or she determines that specific site conditions warrant such design.
4. When approved for use by the building official, a crib wall earth retention system may be used. Such system must be specifically recommended, as an appropriate method of retaining a cut or fill slope, by the geotechnical engineer of record for the project.
5. Any crib wall earth retention system which is approved for use by the building official, must meet the following minimum design parameters:
 - a. The crib wall system shall be designed with a minimum factor of safety against overturning of 3.0. A higher factor of safety may be required, at the discretion of the building official.
 - b. The crib wall system shall be designed with a minimum factor of safety against sliding of 3.0. A higher factor of safety may be required, at the discretion of the building official.
 - c. Unless an alternate height is approved by the building official, the maximum height of a crib wall shall not exceed ten feet (3 m), measured from the bottom of the lowest course.

- d. Crib walls in excess of ten feet (3 m) in height must be designed with closed cell faces, and may not be vegetated.
 - e. Backfill of crib walls shall consist of granular material, which facilitates drainage, as recommended by the geotechnical engineer of record.
 - f. A subdrain shall be required behind all retaining walls, unless the full effect of hydrostatic pressure is accounted for in the design, and omission of such subdrain is recommended by the geotechnical engineer of record for the project, and approved by the building official.
 - g. Crib walls shall be founded upon a foundation/grade beam system that is designed by a licensed civil or structural engineer or upon competent bedrock as determined by both a qualified geotechnical engineer and engineering geologist and approved by the building official. All foundation grade beam systems shall be reviewed and approved by the geotechnical engineer of record for the project.
 - h. Crib walls shall be designed to resist all seismically induced lateral forces, in addition to the lateral forces imparted by retained earth material.
6. Earth retention systems, other than cantilevered retaining wall systems, which are not anchored into a stable, earthen mass may not be utilized.
7. Revetments and erosion control armaments shall not be considered suitable for retaining cut or fill slopes.
8. All retaining walls must be approved by the building official prior to construction, except for walls specifically exempt from the Glendale Building and Safety Code, 2014, as amended.

9. Any earth retaining structure, which creates a reasonably accessible surface, which adjoins a vertical drop of thirty inches (750 mm) or more, shall be provided with a protective guard, in accordance with the Glendale Building and Safety Code, 2014, as amended.
10. All retaining walls shall be provided with sufficient freeboard and a surface back drain, to effectively retain and divert ravel, debris, and concentrated storm water runoff.

SECTION IA-152. Appendix J Section J109.1 of Volume IA of the Glendale Building and Safety Code, 2023, is hereby amended to read as follows:

J109.1 General. Unless otherwise recommended by a civil engineer, and approved by the building official, drainage facilities and terracing shall be provided in accordance with the requirements of this section for all cut and fill slopes where the ground slope is steeper than 3 units horizontal to 1 unit vertical (33 percent slope).

For slopes flatter than 3 units horizontal to 1 unit vertical (33 percent slope) and steeper than 5 units horizontal to 1 unit vertical (20 percent slope) a paved swale or ditch shall be provided at 30 foot (9.1 m) vertical intervals to control surface drainage and debris. Swale shall be sized based on contributory area and have adequate capacity to convey intercepted waters to the point of disposal as defined in Appendix J Section 109.5. Swale must be paved with reinforced concrete not less than 3 inches (0.08 m) in thickness, reinforced with 6-inch (0.2 m) by 6-inch (0.2 m) No. 10 by No. 10 welded wire fabric or equivalent reinforcing centered in the concrete slab or an approved equal. Swale must have a minimum flow line depth of 1 foot (0.3 m) and a minimum paved width of 18 inches (0.5 m). Swales shall have a minimum gradient of not less than 5 percent. There shall be no reduction in grade along the direction of flow unless the velocity of flow is such that slope debris will remain in suspension on the reduced grade.

SECTION IA-153. Appendix J Section J109.3 of Volume IA of the Glendale Building and Safety Code, 2023, is hereby amended to read as follows:

J109.3 Interceptor drains and overflow protection. Berms, interceptor drains, swales or other devices shall be provided at the top of cut or fill slopes to prevent surface waters from overflowing onto and damaging the face of a slope. Berms used for slope protection shall not be less than 12 inches (0.3 m) above the level of the pad and shall slope back at least 4 feet (1.2 m) from the top of the slope. Interceptor drains shall be installed along the top of graded slopes greater than 5 feet (1.5 m) in height receiving drainage from a tributary width greater than 30 feet (9.1 m) measured horizontally. They shall have a minimum depth of 1 foot (305 mm) and a minimum width of 3 feet (915 mm). The slope shall be approved by the building official, but shall not be less than 50 horizontal to 1 vertical (2 percent slope). The drain shall be paved with concrete not less than 3 inches (76 mm) in thickness, or by other materials suitable to the application. Discharge from the drain shall be accomplished in a manner to prevent erosion and shall be approved by the building official.

SECTION IA-154. Appendix J Section J109.5 of Volume IA of the Glendale Building and Safety Code, 2023, is hereby added to read as follows:

J109.5 Disposal. All drainage facilities shall be designed to carry waters to the nearest practicable street, storm drain, or natural watercourse drainage way approved by the building official or other appropriate governmental agency jurisdiction provided it is a safe place to deposit such waters. Erosion of ground in the area of discharge shall be prevented by installation of non-erosive down drains or other devices. Desilting basins, filter barriers or other methods, as approved by the building official, shall be utilized to remove sediments from surface waters before such waters are allowed to enter streets, storm drains, or natural watercourses. If the

drainage device discharges onto natural ground, riprap or a similar energy dissipater may be required. Building pads shall have a minimum drainage gradient of 2 percent toward approved drainage facilities, a public street or drainage structure approved to receive storm waters unless waived by the building official. A lesser slope may be approved by the building official for sites graded in relatively flat terrain, or where special drainage provisions are made, when the building official finds such modification will not result in unfavorable drainage conditions.

SECTION IA-155. Appendix J Section J110.1 of Volume IA of the Glendale Building and Safety Code, 2023, is hereby amended to read as follows:

J110.1 General. The faces of cut and fill slopes shall be prepared and maintained to control erosion. This control shall consist of effective planting, erosion control blankets, soil stabilizers or other means as approved by the building official.

Exception: Erosion control measures need not be provided on cut slopes not subject to erosion due to the erosion-resistant character of the materials.

Erosion control for the slopes shall be installed as soon as practicable and prior to calling for final inspection.

SECTION IA-156. Appendix J Section J111 of Volume IA of the Glendale Building and Safety Code, 2023, is hereby amended to read as follows:

SECTION J111

REFERENCED STANDARDS

ASTM D 1557-12	Test Method for Laboratory Compaction Characteristics of Soil Using Modified Effort [56,000 ft-lf/ft ³ (2,700kN-m/m ³)].
ASTM D 1556	Density and Unit Weight of Soils in Place by the Sand Cone Method

ASTM D 2167	Density and Unit Weight of Soils in Place by the Rubber-Balloon Method
ASTM D 2937	Density of Soils in Place by the Drive-Cylinder Method
ASTM D 2922	Density of Soil and Soil Aggregate in Place by Nuclear Methods
ASTM D 3017	Water Content of Soil and Rock in Place by Nuclear Methods

SECTION IA-157. Appendix J Section J112 of Volume IA of the Glendale Building and Safety Code, 2023, is hereby added to read as follows:

SECTION J112

**NATIONAL POLLUTANT DISCHARGE ELIMINATION SYSTEM (NPDES)
COMPLIANCE**

J112.1 General. All grading plans and permits shall comply with the provisions of this section and Chapters 13.42 and 13.43 of the Glendale Municipal Code for NPDES compliance including the owner of any property on which grading has been performed and which requires a grading permit under Appendix J Section J103. Sites which have been graded and which require a grading permit under Appendix J Section J103 are subject to penalties and fines per Appendix J Section J112.4. All best management practices shall be installed before grading begins or as instructed in writing by the building official for unpermitted grading as defined by Section J103.3. As grading progresses, all best management practices shall be updated as necessary to prevent erosion and control construction related pollutants from discharging from the site. All best management practices shall be maintained in good working order to the satisfaction of the building official unless final grading approval has been granted by the building official and all permanent drainage and erosion control systems, if required, are in place.

J112.2 Storm water pollution prevention plan (SWPPP). When requested by the building official, no grading permit shall be issued unless the plans for such work include a Storm Water Pollution Prevention Plan with details of best management practices, including desilting basins or other temporary drainage or control measures, or both, as may be necessary to control construction-related pollutants which originate from the site as a result of construction related activities. For unpermitted grading as defined by Section J103.3 upon written request a SWPPP in compliance with the provisions of this section and Chapters 13.42 and 13.43 of the Glendale Municipal Code for NPDES compliance shall be submitted to the building official.

J112.3 Wet weather erosion control plans (WWECP). In addition to the SWPPP required in Appendix J Section J112.2, where a grading permit is issued and it appears that the grading will not be completed prior to November 1, then on or before October 1 the owner of the site on which the grading is being performed shall file or cause to be filed with the building official a WWECP which includes specific best management practices to minimize the transport of sediment and protect public and private property from the effects of erosion, flooding or the deposition of mud, debris or construction related pollutants. The best management practices shown on the WWECP shall be installed on or before October 15. The plans shall be revised annually or as required by the building official to reflect the current site conditions. The WWECP shall be accompanied by an application for plan checking services and plan check fees equal in amount to 10 percent of the original grading permit fee.

J112.4 Storm water pollution prevention plan, effect of noncompliance. Should the owner fail to install the best management practices required by Appendix J Sections J112.2 and J112.3 or submit the wet weather erosion control plans required by Appendix J Section J112.3 by the dates specified therein, it shall be deemed that a default has occurred under the conditions of the

grading permit security. There upon, the building official may enter the property for the purpose of installing, by city forces or by other means, the drainage, erosion control and other devices shown on the approved plans, or if there are no approved plans, as the building official may deem necessary to protect adjoining property from the effects of erosion, flooding, or the deposition of mud, debris or construction related pollutants. The building official may also cause the owner to be prosecuted as a violator of this code. The building official shall have the authority to collect the penalties imposed by this code upon determining that the site is in noncompliance. Payment of penalty shall not relieve any persons from fully complying with the requirements of this code in the execution of the work. The following penalties may be imposed by the building official:

1. If a designed wet weather erosion control plan is not submitted as prescribed in Appendix J Section J112.3:

Grading Permit Volume	Penalty
1 – 10,000 cubic yards (1 – 7645.5 m ³)	\$ 50.00 per day
10,001 – 100,000 cubic yards (7646.3 – 76455 m ³)	\$250.00 per day
More than 100,000 cubic yards (76455 m ³)	\$500.00 per day

2. If the best management practices for storm water pollution prevention and wet weather erosion control are not installed as prescribed in Appendix J Sections J112.2 and J112.3 and approved by the building official:

Grading Permit Volume	Penalty
1 – 10,000 cubic yards (1 – 7645.5 m ³)	\$ 100.00 per day
10,001 – 100,000 cubic yards (7646.3 – 76455 m ³)	\$250.00 per day
More than 100,000 cubic yards (76455 m ³)	\$500.00 per day

VOLUME IB. RESIDENTIAL STANDARDS

SECTION IB-1. Volume IB of the Glendale Building and Safety Code, 2023, is amended as hereinafter provided.

SECTION IB-2. Chapter 1 Division II of the Section R104.10.2 of Volume IB of the Glendale Building and Safety Code, 2023, is hereby added to read as follows:

R104.10.2 Fire code official concurrence. For those cases which may affect fire or life safety in buildings regulated by the State Fire Marshall, the building official shall obtain the concurrence of the fire code official if related to fire protection systems, egress, fire department access or water supply.

SECTION IB-3. Chapter 1 Division II Section R104.11.2 of Volume IB of the Glendale Building and Safety Code, 2023, is hereby added to read as follows:

R104.11.2 Fire code official concurrence. For those cases which may affect fire or life safety in buildings regulated by the State Fire Marshall, the building official shall obtain the concurrence of the fire code official if related to fire protection systems, egress, fire department access or water supply.

SECTION IB-4. Chapter 1 Division II Section R105.3 of Volume IB of the Glendale Building and Safety Code, 2023, is hereby amended to read as follows:

R105.3 Application for permit. To obtain a permit, the applicant shall first file an application therefor in writing on a form furnished by the department of building safety for that purpose. Such application shall:

1. Identify and describe the work to be covered by the permit for which application is made.

2. Describe the land on which the proposed work is to be done by legal description, street address or similar description that will readily identify and definitely locate the proposed building or work.
3. Indicate the use and occupancy for which the proposed work is intended.
4. Be accompanied by construction documents and other information as required in Section R106.1.
5. State the valuation of the proposed work.
6. Be signed by the applicant or the applicant's authorized agent.
7. Give such other data and information as required by the building official.
8. Pay plan review and permit fees as required by Volume 1A Chapter 1 Division II of this Code.

SECTION IB-5. Chapter 1 Division II Section R105.3.1.1 of Volume IB of the Glendale Building and Safety Code, 2023, is hereby amended to read as follows:

R105.3.1.1 Determination of substantially improved or substantially damaged existing buildings in flood hazard areas. For applications for reconstruction, rehabilitation, addition, alteration, repair or other improvement of existing buildings or structures located in a flood hazard area as established by Table R301.2(1), the building official shall examine or cause to be examined the construction documents and shall make a determination with regard to the valuation of the proposed work. For buildings that have sustained damage of any origin, the valuation of the proposed work shall include the cost to repair the building or structure to its predamaged condition. If the building official finds that the valuation of proposed work equals or exceeds 50 percent of the market value of the building or structure before the damage has occurred or the improvement is

started, the proposed work is a substantial improvement or repair of substantial damage and the building official shall require existing portions of the entire building or structure to meet the requirements of Section R322.

SECTION IB-6. Chapter 1 Division II Section R105.3.1.2 of Volume IB of the Glendale Building and Safety Code, 2023, is hereby added to read as follows:

R105.3.1.2 Small residential rooftop solar energy system review process.

- A. **Applicability.** This Section applies to the permitting of all small residential rooftop solar energy systems, as defined herein, in the city.
- B. **Definitions.** The following words and phrases as used in this section are defined as follows:

“Electronic submittal” means the utilization of email, facsimile, or the internet.

“Small residential rooftop solar energy system” means all of the following:

1. A solar energy system that is no larger than 10 kilowatts alternating current nameplate rating or 30 kilowatts thermal.
2. A solar energy system that conforms to all applicable state fire, structural, electrical, and other building codes as adopted or amended by the city and paragraph (iii) of subdivision (c) of Section 714 of the Civil Code, as such section or subdivision may be amended, renumbered, or redesignated from time to time.
3. A solar energy system that is installed on a single or duplex family dwelling.
4. A solar panel or module array that does not exceed the maximum legal building height as defined by city.

“**Solar energy system**” has the same meaning set forth in paragraphs (1) and (2) of subdivision (a) of Section 801.5 of the California Civil Code, as such section or subdivision may be amended, renumbered, or redesignated from time to time.

“**Specific, adverse impact**” means a significant, quantifiable, direct, and unavoidable impact, based on objective, identified, and written public health or safety standards, policies, or conditions as they existed on the date the application was deemed complete.

C. Solar Energy System Requirements

1. All solar energy systems shall meet applicable health and safety standards and requirements imposed by the State of California and of the city of Glendale, including the Glendale Fire Department and the Glendale Water and power department.
2. Solar energy systems for heating water in single-family residences and for heating water in commercial or swimming pool applications shall be certified by an accredited listing agency as defined by the California Plumbing and Mechanical Code.
3. Solar energy systems for producing electricity shall meet all applicable safety and performance standards established by the California Electrical Code, the Institute of Electrical and Electronics Engineers, and accredited testing laboratories such as Underwriters Laboratories and, where applicable, rules of the Public Utilities Commission regarding safety and reliability.

D. Expedited Permitting Process and Checklist, and Permit Fees.

1. On or before September 30, 2015, the building official shall adopt an expedited permitting process for small residential rooftop solar energy systems, including a standard plan and checklist(s) of all requirements with which small residential rooftop solar energy systems shall comply to be eligible for expedited review.
2. The checklist and all documents required for the submission of an expedited small residential solar energy system application shall be made available to the public on the City of Glendale website. The Building Official shall allow for electronic submittal of permit applications covered by this Ordinance and associated supporting documentations. In accepting such permit applications, the Building Official shall also accept electronic signatures on all forms, applications, and other documentation in lieu of a wet signature by any applicant.
3. The fees prescribed for the permitting of small residential rooftop solar energy system shall be established from time to time by resolution of the city council and shall be in compliance with Government Code Section 65850.55, Government Code Section 66015, Government Code Section 66016, and State Health and Safety Code Section 17951.

E. Prior to submitting an application for permits for a small residential rooftop solar system, the applicant shall:

1. Verify to the applicant's reasonable satisfaction through the use of standard engineering evaluation techniques that the support structure for the small

residential rooftop solar energy system is stable and adequate to transfer all wind, seismic, and dead and live loads associated with the system to the building foundation; and

2. At the applicant's cost, verify to the applicant's reasonable satisfaction using standard electrical inspection techniques that the existing electrical system including existing line, load, ground and bonding wiring as well as main panel and subpanel sizes are adequately sized, based on the existing electrical system's current use, to carry all new photovoltaic electrical loads.

F. An application that satisfies the information requirements in the checklist, as determined by the building official, shall be deemed complete. Upon receipt of an incomplete application, the building official shall issue a written correction notice detailing all deficiencies in the application and any additional information required to be eligible for expedited permit issuance.

G. A building official may require an applicant to apply for a use permit if the official finds, based on substantial evidence, that the solar energy system could have a specific, adverse impact upon the public health and safety. Such decisions may be appealed to the City Planning Commission. If a use permit is required, a building official may deny an application for the use permit if the official makes written findings based upon substantive evidence in the record that the proposed installation would have a specific, adverse impact upon public health or safety and there is no feasible method to satisfactorily mitigate or avoid, as defined, the adverse impact. Such findings shall include the basis for the rejection of the

potential feasible alternative for preventing the adverse impact. Such decisions may be appealed to the City Planning Commission.

- H. Any condition imposed on an application shall be designed to mitigate the specific, adverse impact upon health and safety at the lowest possible cost.
- I. “A feasible method to satisfactorily mitigate or avoid the specific, adverse impact” includes, but is not limited to, any cost-effective method, condition, or mitigation imposed by the City on another similarly situated application in a prior successful application for a permit. The City shall use its best efforts to ensure that the selected method, condition, or mitigation meets the conditions of subparagraphs (A) and (B) of paragraph (1) of subdivision (d) of Section 714 of the Civil Code defining restrictions that do not significantly increase the cost of the system or decrease its efficiency or specified performance.
- J. Upon confirmation by the building official of the application and supporting documentation being complete and meeting the requirements of the checklist, the building official shall administratively approve the application and issue all required permits or authorizations. Such approval does not authorize an applicant to connect the small residential rooftop energy system to the local utility provider’s electricity grid. The applicant is responsible for obtaining such approval or permission from the local utility provider.
- K. For a small residential rooftop solar energy system eligible for expedited review, only one inspection shall be required, which shall be done in a timely manner and may include a consolidated inspection by the building official and fire chief. If a small residential rooftop solar energy system fails inspection, a subsequent

inspection is authorized; however, the subsequent inspection need not conform to the requirements of this subsection.

SECTION IB-7. Chapter 1 Division II Section R105.3.2 of Volume IB of the Glendale Building and Safety Code, 2023, is hereby amended to read as follows:

R105.3.2 Time limitation of application. An application for a permit for any proposed work shall be deemed to have been abandoned one-year after the date of filing unless such application has been pursued in good faith or a permit has been issued; except that the building official is authorized to grant one or more extensions of time for additional periods not exceeding 180 days each. The extension shall be requested in writing and justifiable cause demonstrated.

In granting any extension the building official may require compliance with any new regulation. In order to renew action on an application after expiration, the applicant shall resubmit plans and pay a new plan review fee. The new plan review fee shall be one half the amount required for a new plan review, provided no changes have been made in the original plans and specifications for such work, and provided further that such abandonment has not exceeded one year. In order to renew action on an expired application the applicant shall comply with all applicable new regulations.

SECTION IB-8. Chapter 1 Division II of the Section R105.3.3 of Volume IB of the Glendale Building and Safety Code, 2023, is hereby added to read as follows:

R105.3.3 Plan review fees. When submittal documents are required by Chapter I Division II, Section R105.3, a plan review fee shall be paid at the time of submitting the submittal documents for plan review. The plan review fees specified in this section are separate fees from the permit fees specified in Chapter 1 Division II, Section R108.2 and

are in addition to the permit fees. When submittal documents are incomplete or changed so as to require additional plan review, or when the project involves deferred submittal items as defined in Chapter 1 Division II, Section 106.3.4, an additional plan review fee shall be charged at a rate specified by resolution.

SECTION IB-9. Chapter 1 Division II Section R105.5 of Volume IB of the Glendale Building and Safety Code, 2023, is hereby amended to read as follows:

R105.5. Expiration. Every permit issued shall become invalid unless the work authorized by such permit is commenced within 180 days after its issuance or after commencement of work if more than 180 days pass between inspections. The building official is authorized to grant, in writing, one or more extensions of time, for periods not more than 180 days each. The extension shall be requested in writing and justifiable cause demonstrated. Work shall be considered suspended or abandoned if the building official determines that substantial work has not been performed within the time specified above. Substantial work shall be construed to mean:

1. Measurable work such as, but not limited to, the addition of footings, structural members, flooring, wall covering, etc.
2. The work mentioned in subsection 1 of this Section 105.5 above must constitute 20% of the value of the work for which the permit was issued in any 180-day period for Group R, Division 3 occupancies.

Before such work can be recommenced, a new permit shall be first obtained to do so, and the fee therefore shall be one half the amount required for a new permit for such work, provided no changes have been made or will be made in the original plans and specifications for such work, and provided further that such

suspension or abandonment has not exceeded one year. In order to renew action on a permit after expiration, the permittee shall pay a new permit fee and may be required to comply with all applicable new regulations at the time of issuance. The building official is authorized to grant, in writing, one or more extensions of time, for periods not more than 180 days each. The extension shall be requested in writing and justifiable cause demonstrated.

SECTION IB-10. Chapter 1 Division II Section R105.8 of Volume IB of the Glendale Building and Safety Code, 2023, is hereby amended to read as follows:

R105.8 Responsibility of permittee. Building permits shall be presumed to incorporate the provision that the applicant, the applicant's agent, employees or contractors shall carry out the proposed work in accordance with the approved plans and with all requirements of this code and any other laws or regulations applicable thereto, whether specified or not. No approval shall relieve or exonerate any person from the responsibility of complying with the provisions and intent of this code.

SECTION IB-11. Chapter 1 Division II of the Section R106.3.4 of Volume IB of the Glendale Building and Safety Code, 2023, is hereby added to read as follows:

R106.3.4 Deferred submittals. For the purposes of this section, deferred submittals are defined as those portions of the design that are not submitted at the time of the application and that are to be submitted to the *building official* within a specified period. Deferral of any submittal items shall have the prior approval of the *building official*. The *registered design professional in responsible charge* shall list the deferred submittals on the *construction documents* for review by the *building official*. Documents for deferred submittal items shall be submitted to the *registered design professional in responsible*

charge who shall review them and forward them to the *building official* with a notation indicating that the deferred submittal documents have been reviewed and been found to be in general conformance to the design of the building. The deferred submittal items shall not be installed until the deferred submittal documents have been *approved by the building official*.

SECTION IB-12. Chapter 1 Division II Section R108.6 of Volume IB of the Glendale Building and Safety Code, 2023, is hereby amended to read as follows:

R108.6 Work commencing before permit issuance. Any person who commences work requiring a permit on a building, structure, electrical, gas, mechanical or plumbing system before obtaining the necessary permits shall be subject to a fee in-addition to the normally established permit fee, equal to 100% of such normally established permit fee, or as otherwise determined by the building official.

SECTION IB-13. Chapter 1 Division II Section R109.1.5.4 of Volume IB of the Glendale Building and Safety Code, 2023, is hereby added to read as follows:

R109.1.5.4 Structural observation. For structural observation, see Section 1704 of Volume IA.

SECTION IB-14. Chapter 1 Division II Section R109.1.5.5 of Volume IB of the Glendale Building and Safety Code, 2023, is hereby added to read as follows:

R109.1.5.5 Sound transmission control. Fire-resistance-rated construction inspection. Where fire-resistance-rated construction is required between dwelling units or due to location on property, the building official shall require an inspection of such construction after all lathing and/or wallboard is in place, but before any plaster is applied,

or before wall-board joints and fasteners are taped and finished. Protection of joints and penetrations in fire resistance rated assemblies shall not be concealed from view until inspected and approved.

SECTION IB-15. Chapter 1 Division II Section R109.5 of Volume IB of the Glendale Building and Safety Code, 2023, is hereby added to read as follows:

R109.5 Reinspections. A reinspection fee may be assessed for each inspection or reinspection when such portion of work for which inspection is called is not complete or when corrections called for are not made.

This section shall not be interpreted as requiring reinspection fees the first time a job is rejected for failure to comply with the requirements of this code, but as controlling the practice of calling for inspections before the job is ready for such inspection or reinspection.

Reinspection fees may be assessed when the approved plans and inspection card are not readily available to the inspector, for failure to provide access on the date for which inspection is requested, or deviation from plans requiring the approval of the Building Official.

To obtain a reinspection, the applicant shall pay the re-inspection fee in accordance with a fee schedule adopted by this jurisdiction.

SECTION IB-16. Chapter 1 Division II Section R112 and all subsections thereof of Volume IB of the Glendale Building and Safety Code, 2023, is hereby amended to read as follows:

SECTION R112

BUILDING AND FIRE BOARD OF APPEALS

R112.1 General. In order to hear and decide appeals of orders, decisions or determinations made by the building official or the fire code official relative to the application and interpretation of this code, there shall be and is hereby created a joint building and fire board of appeals in accordance with Section 113 of Volume IA of this Code (hereinafter referred to as the "board").

SECTION IB-17. Chapter 1 Division II Section R113.1 of Volume IB of the Glendale Building and Safety Code, 2023, is hereby amended to read as follows:

R113.1 Unlawful acts. It shall be unlawful for any person, firm or corporation to erect, construct, alter, extend, repair, move, remove, demolish, ~~or~~ occupy, or maintain any building, structure or equipment regulated by this code, or cause same to be done, in conflict with or in violation of any of the provisions of this code. Maintenance of a building or structure which was unlawful at the time it was constructed and which would be unlawful under this Code if constructed after the effective date of such Code, shall constitute a continuing violation of such Code.

SECTION IB-18. Chapter 1 Division II Section R113.4 of Volume IB of the Glendale Building and Safety Code, 2023, is hereby amended to read as follows:

R113.4 Violation penalties. Any person who violates a provision of this code or fails to comply with any of the requirements thereof or who erects, constructs, alters or repairs a building or structure in violation of the approved construction documents or directive of the building official, or of a permit or certificate issued under the provisions of this code, shall be deemed guilty of a misdemeanor and shall be punishable by a fine of not more than \$1,000 or by imprisonment of not more than 6 months, or by both such fine and imprisonment.

Such penalty and imprisonment shall not preclude the imposition of any other administrative or judicial civil, or criminal remedies under state, federal or local laws.

SECTION IB-19. Chapter 1 Division II Section R114.1 of Volume IB of the Glendale Building and Safety Code, 2023, is hereby amended to read as follows:

R114.1 Notice to owner or the owner's authorized agent. Upon notice from the building official that work on any building or structure is being executed contrary to the provisions of this code or other laws or ordinances of this jurisdiction or in an unsafe and dangerous manner, such work shall be immediately stopped. The stop work order shall be in writing and shall be given to the owner of the property involved, or to the owner's authorized agent or to the person performing the work and shall state the conditions under which work will be permitted to resume.

SECTION IB-20. Chapter 1 Division II Section R114.2 of Volume IB of the Glendale Building and Safety Code, 2023, is hereby amended to read as follows:

R114.2 Unlawful continuance. Any person who shall continue any work in or about the structure after having been served with a stop work order, except such work as that person is directed to perform to remove a violation or unsafe condition, shall be guilty of a misdemeanor. Such work shall constitute a continuing violation of this Code.

SECTION IB-21. Chapter 1 Division II Section R115 of Volume IB of the Glendale Building and Safety Code, 2023, is hereby added to read as follows:

SECTION R115

UNSAFE STRUCTURES AND EQUIPMENT

R115.1 Conditions. Structures or existing equipment that are or hereafter become unsafe, insanitary or deficient because of inadequate means of egress facilities, inadequate light and ventilation, or which constitute a fire hazard, or are otherwise dangerous to human life or the public welfare, or that involve illegal or improper occupancy or inadequate maintenance, shall be deemed an unsafe condition. Unsafe structures shall be taken down and removed or made safe, as the building official deems necessary and as provided for in this section. A vacant structure that is not secured against entry shall be deemed unsafe.

R115.2 Record. The building official shall cause a report to be filed on an unsafe condition. The report shall state the occupancy of the structure and the nature of the unsafe condition.

R115.3 Notice. If an unsafe condition is found, the building official shall serve on the owner, agent or person in control of the structure, a written notice that describes the condition deemed unsafe and specifies the required repairs or improvements to be made to abate the unsafe condition, or that requires the unsafe structure to be demolished within a stipulated time. Such notice shall require the person thus notified to declare immediately to the building official acceptance or rejection of the terms of the order.

R115.4 Method of service. Such notice shall be deemed properly served if a copy thereof is (a) delivered to the owner personally; (b) sent by certified or registered mail addressed to the owner at the last known address with the return receipt requested; or (c) delivered in any other manner as prescribed by local law. If the certified or registered letter is returned showing that the letter was not delivered, a copy thereof shall be posted in a conspicuous place in or about the structure affected by such notice. Service of such notice in the foregoing

manner upon the owner's agent or upon the person responsible for the structure shall constitute service of notice upon the owner.

R115.5 Restoration. The structure or equipment determined to be unsafe by the building official is permitted to be restored to a safe condition. To the extent that repairs, alterations or additions are made or a change of occupancy occurs during the restoration of the structure, such repairs, alterations, additions or change of occupancy shall comply with the requirements of Section 105.2.2 and Existing Building Code of Volume IC of this Code.

R115.6 Non-Compliance. Upon failure to comply with the order within the time specified herein, and if no appeal has been properly and timely filed, the building official shall file in the office of the County Recorder a certificate describing the property and certifying (i) that the building is an unsafe building and (ii) that the owner has been notified. Whenever the corrections ordered shall thereafter have been completed or the building demolished so that it no longer exists as an unsafe building on the property described in the certificate, the building official shall file a new certificate with the County Recorder certifying that the building has been demolished or all required corrections have been made so that the building is no longer unsafe, whichever is appropriate.

R115.7 Vacated Buildings. Any unsafe building ordered vacated in accordance with this section shall not be reoccupied until the unsafe conditions have been eliminated. Each such vacated building shall be locked and otherwise secured against entry and the building official shall post thereon a placard stating: "DO NOT ENTER, UNSAFE TO OCCUPY, CITY OF GLENDALE." Such notice shall remain posted until the required repairs, demolition or removal are completed. Such notice shall not be removed without

written permission of the building official and no person shall enter the building except for the purpose of making the required repairs or of demolishing the building.

SECTION IB-22. Chapter 1 Division II Section R116 of Volume IB of the Glendale Building and Safety Code, 2023, is hereby added to read as follows:

SECTION R116

CONSTRUCTION TOILET FACILITIES

R116 Temporary Construction Toilets. Toilet Facilities Required. No person shall commence or proceed with the erection, construction, alteration, repair, raising, adding to, removal, or demolition of any building or structure unless adequate, suitable, sanitary toilet facilities under the control of such person are provided for the use of any person employed or working upon such building or structure. Such toilet facilities shall be located upon or within a reasonable distance of the lot, premises, or site upon which such work is being done. In no case shall the line of travel to any facility exceed 500 feet (153 M). Toilets may not be placed on the public way.

R116.1 Toilet Standards. Every toilet shall be of water flush type and shall be connected to a public sewer or private sewage disposal system built in accordance with the provisions of the Plumbing Code. All toilet structures shall be self-closing; the toilet floor shall be smooth, and screened ventilation shall be provided for the toilet compartment. Where workmen are employed during night hours, the toilet building shall be provided with artificial light. In lieu of flush water closets approved chemical toilets may be provided. Toilets may not be located within 10' (3054 mm) of a property line.

SECTION IB-23. Chapter 1 Division II Section R117 of Volume IB of the Glendale Building and Safety Code, 2023, is hereby added to read as follows:

SECTION R117

ON SITE CONSTRUCTION TRASH AND DEBRIS CONTROL

R117 On Site Construction Trash and Debris Control Facilities Required.

No person shall commence or proceed with erection, construction, alteration, repair, raising, adding to, removal, or demolition of any building or structure unless adequate, suitable on site trash and debris control facilities under the control of such person are provided for the use of any person employed or working upon such building or structure. On site trash and debris control shall consist of at least a roll off 523 ft³ (15m³) bin. The container shall be emptied often enough so that no storage of trash is outside the bin. The bin shall be removed from the site after the building has passed final inspection or within thirty (30) days of the expiration of the building permit.

Exception: Additions, less than 900 ft² (84m²), and alterations to Group R, Division 3 occupancies and Group U occupancies need not provide a roll off bin but must store trash and debris in the rear yard in quantities less than 10 ft (3m) wide by 10 ft (3m) long by 4 ft (1.2m) high. All trash and debris whether or not in containers shall be kept 3 ft (912mm) from adjacent property lines.

SECTION IB-24. Chapter 1 Division II Section R118 of Volume IB of the Glendale Building and Safety Code, 2023, is hereby added to read as follows:

SECTION R118

DISASTER REPAIR AND RECONSTRUCTION

R118.1 Intent. This section establishes standards and regulations for the expeditious repair and reconstruction of structures damaged as a result of a disaster for which a local emergency has been declared by the City Council. This section does not allow

exemptions from the Building, Fire, Electrical, Mechanical, Plumbing, other Codes, or standards.

R118.2 Applications of Provisions.

R118.2.1 The provisions of this section are applicable following each disaster when a local emergency has been declared by the City Council to all buildings and structures of all occupancies regulated by the City of Glendale. The Council may extend the provisions as necessary.

R118.2.2 When approved by the building official, the requirements of this section may be waived in favor of repair recommendations included in an engineering evaluation as defined in Section R118.3.

R118.3 DEFINITIONS. For the purpose of this Section R118, the following definitions apply:

R118.3.1 “ARCHITECT” means an individual licensed by the State of California to practice architecture as defined in the State of California Business and Professions Code.

R118.3.2 “CIVIL ENGINEER” means an individual registered by the State of California to practice civil engineering as defined in the State of California Business and Professions Code.

R118.3.3 “CURRENT CODE” means the edition of the California Residential Code, published by the International Code Council, as adopted by the City of Glendale as the Glendale Building and Safety Code, as amended. The edition of said Glendale Building and Safety Code to be applied shall be that edition in effect at the time of the declaration of a local emergency by the City Council.

R118.3.4 “ENGINEERING EVALUATION” means an evaluation of a damaged

building or structure, or suspected damaged building or structure, performed under the direction of a structural engineer, civil engineer, or architect retained by the owner of the building or structure. Engineering evaluations shall, at a minimum, contain recommendations for repair with appropriate opinion of construction cost for those repairs.

R118.3.5 “REPLACEMENT VALUE” means the dollar value, as determined by the building official, of replacing the damaged structure with a new structure of the same size, construction material and occupancy on the same site.

R118.3.6 “STRUCTURAL ENGINEER” means an individual registered by the State of California to practice civil engineering and to use the title structural engineer as defined in the State of California Business and Professions Code. **R118.3.7 “VALUE OF REPAIR”** means the dollar value, as determined by the building official, of making the necessary repairs to the damaged building.

R118.4 Repair Criteria.

R118.4.1 Abatement of Dangerous Buildings shall be in accordance with the provisions of Chapter 1 Division II, Section R115.

R118.4.2 Building and structures of all occupancies which have been damaged as a result of a disaster, except as otherwise noted, shall be repaired in accordance with the following criteria:

1. When the estimated value of repair does not exceed ten percent (10%) of the replacement value of the structure, the damaged portion(s) may be restored to their pre-disaster condition.

Exception: When the damaged elements include suspended

ceiling systems, the ceiling system shall be repaired and all bracing required by current code shall be installed.

2. When the estimated value of repair is greater than ten percent (10%) but less than fifty percent (50%) of the replacement value of the structure, the damaged elements, as well as all critical ties, supported elements and supporting elements associated with the damaged elements, shall be repaired and/or brought into conformance with the structural requirements of the current Code.
3. When the estimated value of repair is fifty percent (50%) or more of the replacement value of the structure, the entire structure shall be brought into conformance with the structural requirements of the current Code.
4. In Group R, Division 3 occupancies, the repair value of damaged chimneys shall be excluded from the computation of percentage of replacement value. Damaged chimneys shall be repaired in accordance with Chapter 1 Division II, Section 118.5.

R118.5 Repair Criteria for Chimneys.

R118.5.1 All damaged chimneys must be repaired or reconstructed to comply with the requirements of Section 2113 of the Glendale Building and Safety Code, 2023. Damaged portions of chimneys shall be removed in accordance with the following criteria:

1. When the damaged portion of the chimney is located between the roof line and the top of the chimney, the damaged portion shall be removed to the roof line provided the roof and ceiling anchorage are in sound condition.

2. For a single-story structure in which the damaged portion of the chimney is below the roof line or the damaged portion extends from above the roof line to below the roof line, the chimney shall be removed to the top of the fire box.
3. For a multi-story structure, the damaged portion of the chimney shall be removed from the top to a floor line where sound anchorage is found.
4. In any structure where the firebox has been damaged, the entire chimney and firebox shall be removed to the foundation. If this foundation is in sound condition, the firebox and chimney may be reconstructed using the existing foundation. If the foundation has been damaged, the foundation shall be removed and replaced.

R118.5.2 Where existing conditions preclude the installation of all anchorage required by Section 2113 of Volume IA of this Code, alternate systems may be used in accordance with the alternate methods and materials provisions of said Code when approved by the building official. Such alternate systems shall be designed and detailed by a structural engineer, civil engineer, or architect.

R118.6 Repair Criteria for Unreinforced Masonry Buildings and Structures.

R118.6.1 All buildings as described in Appendix Chapter A1, Section A102.1 of the California Existing Building Code of Volume IC of the Glendale Building and Safety Code that are damaged shall be repaired and strengthened in accordance with provisions of Chapter I Division II, Section R118.4.

118.6.2 Unreinforced masonry buildings damaged less than 50% shall be repaired in accordance with California Existing Building Code, Appendix Chapter A1, Seismic

Strengthening Provisions for Unreinforced Masonry Bearing Wall Buildings of Volume IC of this Code.

SECTION IB-25. Chapter 1 Division II Section R119 of Volume IB of the Glendale Building and Safety Code, 2023, is hereby added to read as follows:

SECTION R119

SANDBLASTING

R119.1. Sandblasting: Definition. As used in this article, unless the context expressly indicates otherwise, "sandblasting" shall mean the use of air, steam or water containing sand to clean, grind, or cut hard surfaces.

R119.2. Dry Sandblasting. Dry sandblasting is prohibited unless authorized by special permission from the building official endorsed upon a permit. Permission for dry sandblasting may be granted only when it is not possible to employ wet sandblasting. When dry sandblasting is permitted, the building official may impose such reasonable and related conditions as he or she may deem necessary for the protection of the public and the adjacent property.

R119.3. Use of Canvas. Sandblasting operations shall, at all times, be separated from all adjacent property by canvas or other suitable barrier to prevent the splashing or blowing of water and/or sand thereupon.

R119.4. Stoppage of Work. The building official may order the immediate stoppage of sandblasting for failure to comply with any provision of this chapter. Failure of any person to comply immediately with such order shall constitute a misdemeanor.

SECTION IB-26. Chapter 1 Division II Section R120 of Volume IB of the Glendale Building and Safety Code, 2023, is hereby added to read as follows:

SECTION R120

PROTECTION OF PEDESTRIANS

R120.1 Protections required. Pedestrians shall be protected during construction, remodeling and demolition activities as required by this section. Signs shall be provided to direct pedestrian traffic.

R120.2 Walkways. A walkway shall be provided for pedestrian travel in front of every construction and demolition site unless the applicable governing authority authorizes the sidewalk to be fenced or closed. Walkways shall be of sufficient width to accommodate the pedestrian traffic, but in no case shall they be less than 5 feet (1524 mm) in width. Walkways shall be provided with a durable walking surface. Walkways shall be accessible in accordance with the California Building Code Chapter 11A or 11B as applicable, and shall be designed to support all imposed loads and in no case shall the design live load be less than 150 pounds per square foot (psf) (7.2 kN/m²).

SECTION IB-27. Section R301.1.3.1 of Volume IB of the Glendale Building and Safety Code, 2023, is hereby amended to read as follows:

R301.1.3.1 California licensed architect or engineer.

All construction documents submitted for permit shall be approved and stamped by a California licensed architect or engineer.

Exception: When the building official determines, based upon a review of the construction documents submitted, that the scope of work is minor in nature.

SECTION IB-28. Section R301.1.3.2 of Volume IB of the Glendale Building and Safety Code, 2023, regarding engineered design for woodframe structures greater than two-stories, is hereby amended.

R301.1.3.2 Woodframe structures. The building official shall require construction documents to be approved and stamped by a California licensed architect or engineer for all dwellings of woodframe construction more than two stories and basement in height located in Seismic Design Category A, B or C. Notwithstanding other sections of law, the law establishing these provisions is found in Business and Professions Code Sections 5537 and 6737.1.

The building official shall require construction documents to be approved and stamped by a California licensed architect or engineer for all dwellings of woodframe construction more than one story in height or with a basement located in Seismic Design Category D₀, D₁, or D₂.

SECTION IB-29. Section R301.1.3.3 of Volume IB of the Glendale Building and Safety Code, 2023, regarding engineered design for structures other than woodframe, is hereby repealed.

SECTION IB-30. Section R301.1.5 of Volume IB of the Glendale Building and Safety Code, 2023, is hereby added to read as follows:

R301.1.5 Seismic design provisions for buildings constructed on or into slopes steeper than one-unit vertical in three units horizontal (33.3 percent slope). The design and construction of new buildings and additions to existing buildings when constructed on or into slopes steeper than one-unit vertical in three units horizontal (33.3 percent slope) shall comply with Section 1613.6 of Volume IA of this Code.

SECTION IB-31. Table R301.2 of Volume IB of the Glendale Building and

Safety Code, 2023, is hereby amended to read as follows:

TABLE R301.2 CLIMATIC AND GEOGRAPHIC DESIGN CRITERIA

GROUND SNOW LOAD	WIND DESIGN				SEISMIC DESIGN CATEGORY ^f	SUBJECT TO DAMAGE FROM			WINTER DESIGN TEMP ^e	ICE BARRIER UNDERLAYMENT REQUIRED ^h	FLOOD HAZARDS ^g	AIR FREEZING INDEX ⁱ	MEAN ANNUAL TEMP ^j
	Speed ^d (mph)	Topographic effects ^k	Special wind region ^l	Wind-borne debris zone ^m		Weathering ^a	Frost line depth ^b	Termite ^c					
0	110	No	No	No	See Footnote f	Negligible	12 in.	N/A	47°F	No	See Footnote g	None	63.9
MANUAL J DESIGN CRITERIA ⁿ													
Elevation	Latitude		Winter Heating	Summer cooling	Altitude Correction factor		Indoor design Temperature	Design Temperature cooling	Heating temperature differences				
-----	-----		-----	-----	-----		-----	-----	-----		-----		
Cooling Temperature difference	Wind Velocity heating		Wind Velocity cooling	Coincident wet bulb	Daily range		Winter humidity	Summer humidity					
-----	-----		-----	-----	-----		-----	-----					

For SI: 1 pound per square foot = 0.0479 kPa, 1 mile per hour = 0.447 m/s.

- a. Where weathering requires a higher strength concrete or grade of masonry than necessary to satisfy the structural requirements of this code, the frost line depth strength required for weathering shall govern. The weathering column shall be filled in with the weathering index, "negligible," "moderate" or "severe" for concrete as determined from Figure R301.2(4). The grade of masonry units shall be determined from ASTM C34, C55, C62, C73, C90, C129, C145, C216 or C652.
- b. Where the frost line depth requires deeper footings than indicated in Figure R403.1(1), the frost line depth strength required for weathering shall govern. The jurisdiction shall fill in the frost line depth column with the minimum depth of footing below finish grade.
- c. The jurisdiction shall fill in this part of the table to indicate the need for protection depending on whether there has been a history of local subterranean termite damage.

- d. The jurisdiction shall fill in this part of the table with the wind speed from the basic wind speed map [Figure R301.2(5)A]. Wind exposure category shall be determined on a site-specific basis in accordance with Section R301.2.1.4.
- e. Temperatures shall be permitted to reflect local climates or local weather experience as determined by the building official. [Also see Figure R301.2(1).10]
- f. The jurisdiction shall fill in this part of the table with the seismic design category determined from Section R301.2.2.1. See Mapped acceleration and other seismic design parameters at the USGS Web site.
- g. The jurisdiction shall fill in this part of the table with (a) the date of the jurisdiction's entry into the National Flood Insurance Program (date of adoption of the first code or ordinance for management of flood hazard areas), (b) the date(s) of the Flood Insurance Study and (c) the panel numbers and dates of all currently effective FIRMs and FBFMs or other flood hazard map adopted by the authority having jurisdiction, as amended.

The City of Glendale (Community No. 065030) has participated as a regular member in the NFIP since August 31, 1984

Date of the Flood Insurance Study: September 26, 2008

FIRM Numbers, Dates:

06037C1095E, September 30, 2005

06037C1125F, September 30, 2005

06037C1335E, September 30, 2005

06037C1345E, September 30, 2005

06037C1375E, September 30, 2005

06037C1610E, September 30, 2005

06037C1626E, September 30, 2005

- h. In accordance with Sections R905.1.2, R905.4.3.1, R905.5.3.1, R905.6.3.1, R905.7.3.1 and R905.8.3.1, where there has been a history of local damage from the

effects of ice damming, the jurisdiction shall fill in this part of the table with "YES."

Otherwise, the jurisdiction shall fill in this part of the table with "NO."

- i. The jurisdiction shall fill in this part of the table with the 100-year return period air freezing index (BF-days) from Figure R403.3(2) or from the 100-year (99%) value on the National Climatic Data Center data table "Air Freezing Index- USA Method (Base 32°)" at www.ncdc.noaa.gov/fpsf.html.
- j. The jurisdiction shall fill in this part of the table with the mean annual temperature from the National Climatic Data Center data table "Air Freezing Index-USA Method (Base 32°F)" at www.ncdc.noaa.gov/fpsf.html.
- k. In accordance with Section R301.2.1.5, where there is local historical data documenting structural damage to buildings due to topographic wind speed-up effects, the jurisdiction shall fill in this part of the table with "YES." Otherwise, the jurisdiction shall indicate "NO" in this part of the table.
- l. In accordance with Figure R301.2(4)A, where there is local historical data documenting unusual wind conditions, the jurisdiction shall fill in this part of the table with "YES" and identify any specific requirements. Otherwise, the jurisdiction shall indicate "NO" in this part of the table.
- m. In accordance with Section R301.2.1.2, the jurisdiction shall indicate the wind-borne debris wind zone(s). Otherwise, the jurisdiction shall indicate "NO" in this part of the table.
- n. The jurisdiction shall fill in this section of the table to establish the design criteria using Table of 1a or 1b from ACCA Manuel J or established criteria determine by the jurisdiction.

- o. The jurisdiction shall fill in this section of the table using the Ground Snow Loads in Figure R301.2(6).

SECTION IB-32. Section R301.2.2.6 of Volume IB of the Glendale Building and Safety Code, 2023, is hereby amended to read as follows:

R301.2.2.6 Irregular buildings. The seismic provisions of this code shall not be used for structures, or portions thereof, located in Seismic Design Categories C, D₀, D₁ and D₂ and considered to be irregular in accordance with this section. A building or portion of a building shall be considered to be irregular where one or more of the conditions defined in Items 1 through 7 occur. Irregular structures, or irregular portions of structures, shall be designed in accordance with accepted engineering practice to the extent the irregular features affect the performance of the remaining structural system. When the forces associated with the irregularity are resisted by a structural system designed in accordance with accepted engineering practice, the remainder of the building shall be permitted to be designed using the provisions of this code.

1. **Shear wall lines or braced wall offsets out of plane.** Conditions where exterior shear wall lines or braced wall panels are not in one plane vertically from the foundation to the uppermost story in which they are required.
2. **Lateral support of roofs and floors.** Conditions where a section of floor or roof is not laterally supported by shear walls or braced wall lines on all edges.

Exception: Portions of floors that do not support shear walls, braced wall panels above, or roofs shall be permitted to extend no more than 6 feet (1829 mm) beyond a shear wall or braced wall line.

3. **Shear wall or braced wall offsets in plane.** Conditions where the end of a braced wall panel occurs over an opening in the wall below. **Floor and roof opening.** Conditions where an opening in a floor or roof exceeds the lesser of 12 feet (368 mm) or 50 percent of the least floor or roof dimensions.
4. **Floor level offset.** Conditions where portions of a floor level are vertically offset.
6. **Perpendicular shear wall and wall bracing.** Conditions where shear walls and braced wall lines do not occur in two perpendicular directions.
7. **Wall bracing in stories containing masonry or concrete construction.**
Conditions where stories above grade plane partially or completely braced by wood wall framing in accordance with Section R602 or cold-formed steel wall framing in accordance with Section R603 include masonry or concrete construction. When this irregularity applies, the entire story shall be designed in accordance with accepted engineering practice.

Exception: Fireplaces, chimneys and masonry veneer as permitted by this code.

8. Hillside light-frame construction. Conditions in which all of the following apply:
 - 8.1. The grade slope exceeds 1 unit vertical in 5 units horizontal where averaged across the full length of any side of the dwelling.
 - 8.2. The tallest cripple wall clear height exceeds 7 feet (2134 mm), or where a post and beam system occurs at the dwelling perimeter, the post and beam system tallest post clear height exceeds 7 feet (2134 mm)
 - 8.3. Of the total plan area below the lowest framed floor, whether open or enclosed, less than 50 percent is living space having interior wall

finished conforming to Section R702.

Where Item 8 is applicable, design in accordance with accepted engineering practice shall be provided for the floor immediately above the cripple walls or post and beam system and all structural elements and connections from this diaphragm down to and including connections to the foundation to transfer lateral loads from the framing above.

Exception: Light-frame construction in which the lowest framed floor is supported directly on concrete or masonry walls over the full length of all sides except the downhill side of the dwelling need not be considered an irregular dwelling under item 8.

SECTION IB-33. Section R301.2.2.11 of Volume IB of the Glendale Building and Safety Code, 2023, is hereby added to read as follows:

R301.2.2.11 Anchorage of mechanical, electrical, or plumbing components and equipment. Mechanical, electrical, or plumbing components and equipment shall be anchored to the structure. Anchorage of the components and equipment shall be designed to resist loads in accordance with the California Building Code and ASCE 7, except where the component is positively attached to the structure and flexible connections are provided between the component and associated ductwork, piping, and conduit; and either

1. The component weighs 400 lb (1,780 N) or less and has a center of mass located 4 ft (1.22 m) or less above the supporting structure; or
2. The component weighs 20 lb (89N) or less or, in the case of a distributed system, 5 lb/ft (73 N/m) or less.

SECTION IB-34. Section R302.1.1 of Volume 1B of the Glendale Building and Safety Code, 2020, is hereby added to read as follows:

R302.1.1 Construction on contiguous lots under same ownership or occupancy. In those cases, where lots, or portions of lots, contiguous to one another are owned or occupied by the same person, such lots, or portions of lots, may be considered one lot for the purpose of enforcing Section R302.1, Table R302.1(1), R302.1(2) and Table R302.6 of this Code, in such event, the owner of said lots shall be required to execute and record a covenant and agreement with the City to the satisfaction of the building official on a form approved by the City Attorney. Said covenant and agreement shall, among other things, provide that said lots or portions of lots shall remain as one parcel and the owner thereof shall not sell, transfer or in any way sever any portion of said lots or portions of lots independently from the remaining lots or portions of lots until or unless released from the covenant and agreement by the city. Said covenant and agreement shall be recorded by the Los Angeles County Recorder, shall run with the lot or portions of lots, and shall be binding upon the owner, future owners, encumbrancers, successors, heirs, and assigns. An easement for right of way purposes shall not constitute ownership or occupancy under this Section R302.1.1. The building official is hereby authorized to execute such agreements on behalf of the City.

SECTION IB-35. Section R313 of Volume IB of the Glendale Building and Safety Code, 2023, regarding automatic sprinkler systems is hereby repealed in its entirety and is hereby replaced with the following:

SECTION R313

AUTOMATIC FIRE SPRINKLER SYSTEMS

R313.1 Where required. Approved automatic sprinkler systems in new and existing buildings and structures shall be provided in accordance with this section.

R313.2 New occupancies. An automatic sprinkler system shall be installed in all new occupancies.

R313.3 Existing occupancies. An automatic sprinkler system shall be installed and maintained in all existing occupancies and new sections of any existing building whenever alterations exceed fifty percent (50%) of the replacement value, as determined by the building official. Alteration values shall be cumulative with each application for a building permit within the previous five years.

SECTION IB-36. Section R314.6 of Volume IB of the Glendale Building and Safety Code, 2023, regarding smoke alarm power source is hereby amended to read as follows.

R314.6 Power source. Single-station smoke alarms shall receive their primary power from the building wiring provided that such wiring is served from a commercial source and shall be equipped with a battery backup. Smoke alarms with integral strobes that are not equipped with battery backup shall be connected to an emergency electrical system. Smoke alarms shall emit a signal when the batteries are low. Wiring shall be permanent and without a disconnecting switch other than as required for overcurrent protection.

Exceptions:

1. In buildings constructed under editions of the Glendale Building and Safety Code prior to the 1992 edition, smoke alarms other than those located in the corridor or area giving access to each sleeping area are permitted to be solely battery operated provided no construction or construction requiring a permit

not exceeding \$1000 has taken place, and alterations or repairs do not result in the removal of interior walls or ceiling finishes exposing the structure, unless there is an attic, crawl space or basement available which could provide access for building wiring without the removal of interior finishes.

2. Group R Division 3 occupancies in existence prior to 1973 may utilize smoke alarms that are solely battery powered provided no construction or construction requiring a permit, not exceeding \$1000 has taken place, and alterations or repairs do not result in the removal of interior walls or ceiling finishes exposing the structure, unless there is an attic, crawl space or basement available which could provide access for building wiring without the removal of interior finishes.
3. Smoke alarms that receive their primary power from the building's existing wiring from a commercial source may remain in service without being provided with battery backup. Any smoke alarm that is replaced for any reason shall be provided with battery backup.

SECTION IB-37. Section R319.1 of Volume IB of the Glendale Building and Safety Code, 2023, regarding address numbers is hereby amended to read as follows.

R319.1 Address numbers. Buildings shall be provided with approved address identification. The address identification shall be legible and placed in a position that is visible from the street or road fronting the property. Address identification characters shall contrast with their background. Address numbers shall be Arabic numbers or alphabetical letters. Numbers shall not be spelled out. Each character shall be not less than 4 inches (102mm) in height with a stroke width of not less than 0.5 inch (12.7 mm).

Where required by the fire code official, address identification shall be provided in additional approved locations to facilitate emergency response. Where access is by means of a private road and the building address cannot be viewed from the public way, a monument, pole or other sign or means shall be used to identify the structure. Address identification shall be maintained. Address numbers shall be illuminated in an approved manner.

SECTION IB-38. Section R401.1 of Volume IB of the Glendale Building and Safety Code, 2023, is hereby amended to read as follows:

R401.1 Application. The provisions of this chapter shall control the design and construction of the foundation and foundation spaces for buildings. In addition to the provisions of this chapter, the design and construction of foundations in flood hazard areas as established by Table R301.2 shall meet the provisions of Section R322.

Wood foundations shall be designed and installed in accordance with AWC PWF.

Exception: The provisions of this chapter shall be permitted to be used for wood foundations only in the following situations:

1. In buildings that have no more than two floors and a roof.
2. When interior basement and foundation walls are constructed at intervals not exceeding 50 feet (15 240 mm).

Wood foundations in Seismic Design Category D₀, D₁ or D₂ shall not be permitted.

Exception: In non-occupied, single-story, detached storage sheds and similar uses other than carport or garage, provided the gross floor area does not exceed 200 square feet, the plate height does not exceed 12 feet in height above the grade plane at any point, and the maximum roof projection does not exceed 24 inches.

SECTION IB-39. Section R401.4 of Volume IB of the Glendale Building and Safety Code, 2023, is hereby amended to read as follows:

R401.4 Soil tests. Geotechnical report shall be required for all new construction including new buildings, additions and accessory structures. Any testing shall be done by an approved agency using an approved method.

Exceptions:

1. Buildings and structures not located in the Wildland Urban Interface (WUI) areas, seismic hazard zone, Alquist-Priolo zone or adjacent to slopes greater than 3 units horizontal to 1 unit vertical, and all 1-story additions less than 500 square feet or ancillary structures less than 500 square feet. The foundation design and footings shall comply with the following:
 - a. Soils bearing value shall be a maximum of 1500 pounds per square foot.
 - b. The footing shall be a minimum of 18" wide with a minimum 24" embedment into natural grade or certified fill. One (1) #4 continuous horizontal reinforcement bar shall be located at the top, at the middle and at the bottom of the new footing.

SECTION IB-40. Section R401.5 of Volume 1B of the Glendale Building and Safety Code, 2023, is hereby added to read as follows:

R401.5 Grading. Grading requirements shall be in compliance with Appendix J, GRADING, of Volume IA of this Code.

SECTION IB-41. Section R402.1 of Volume IB of the Glendale Building and Safety Code, 2023, wood foundation systems, is hereby repealed.

SECTION IB-42. Section R403.1.2 of Volume IB of the Glendale Building and Safety Code, 2023, is hereby amended to read as follows:

R403.1.2 Continuous footing in Seismic Design Categories D₀, D₁ and D₂. Exterior walls of buildings located in Seismic Design Categories D₀, D₁ and D₂ shall be supported by continuous solid or fully grouted masonry or concrete footings. Required interior braced wall panels in buildings located in Seismic Design Categories D₀, D₁ and D₂ shall be supported on continuous foundations.

SECTION IB-43. Figure R403.1(2) of Volume IB of the Glendale Building and Safety Code, 2023, regarding permanent wood foundation basement wall section, is hereby repealed.

SECTION IB-44. Figure R403.1(3) of Volume IB of the Glendale Building and Safety Code, 2023, regarding permanent wood foundation crawl space section, is hereby repealed.

SECTION IB-45. Section R403.1.3.6 of Volume IB of the Glendale Building and Safety Code, 2023, is hereby amended to read as follows:

R403.1.3.6 Isolated concrete footings. In detached one- and two-family dwellings located in Seismic Design Category A, B, or C, that are three stories or less in height and constructed with stud bearing walls, isolated plain concrete footings supporting columns or pedestals are permitted.

SECTION IB-46. Section R403.1.5 of Volume IB of the Glendale Building and Safety Code, 2023, is hereby amended to read as follows:

R403.1.5 Slope. The top surface of footings shall be level. The bottom surface of footings shall not have a slope exceeding one unit vertical in 10 units horizontal (10-percent slope). Footings shall be stepped where it is necessary to change the elevation of the top surface of the footings or where the slope of the bottom surface of the footings will exceed one unit vertical in 10 units horizontal (10-percent slope).

For structures assigned to Seismic Design Categories D₀, D₁ or D₂, stepped footings shall be reinforced with four No. 4 rebar. Two bars shall be placed at the top and bottom of the footings as shown in Figure R403.1.5.

**FIGURE R403.1.5
STEPPED FOOTING**

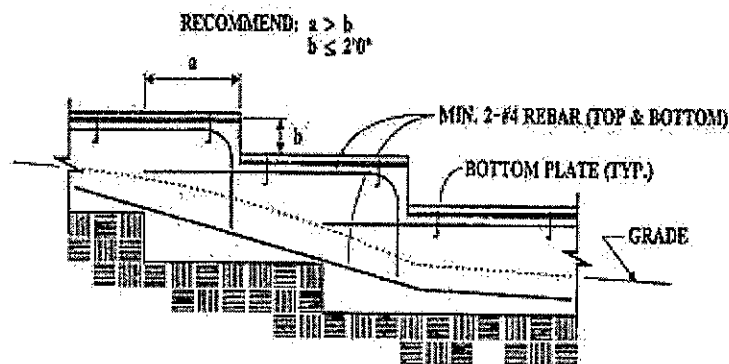

STEPPED FOUNDATIONS

SECTION IB-47. Section R404.2 of Volume IB of the Glendale Building and Safety Code, 2023, is hereby amended to read as follows:

R404.2 Wood foundation walls. Wood foundation walls shall be constructed in accordance with the provisions of Sections R404.2.1 through R404.2.6 and with the details shown in Figures R403.1(2) and R403.1(3). Wood foundation walls shall not be used for structures located in Seismic Design Category D₀, D₁ or D₂.

R404.2.1 Identification. Load-bearing lumber shall be identified by the grade mark of a lumber grading or inspection agency which has been approved by an accreditation body that complies with DOC PS 20. In lieu of a grade mark, a certificate of inspection issued by a lumber grading or inspection agency meeting the requirements of this section shall be accepted. Wood structural panels shall conform to DOC PS 1 or DOC PS 2 and shall be identified by a grade mark or certificate of inspection issued by an approved agency.

R404.2.2 Stud size. The studs used in foundation walls shall be 2-inch by 6-inch (51 mm by 152 mm) members. When spaced 16 inches (406 mm) on center, a wood species with an F_b value of not less than 1,250 pounds per square inch (8619 kPa) as listed in ANSI AWC NDS shall be used. When spaced 12 inches (305 mm) on center, an F_b of not less than 875 psi (6033 kPa) shall be required.

R404.2.3 Height of backfill. For wood foundations that are not designed and installed in accordance with AWC PWF, the height of backfill against a foundation wall shall not exceed 4 feet (1219 mm). When the height of fill is more than 12 inches (305 mm) above the interior grade of a crawl space or floor of a basement, the thickness of the plywood sheathing shall meet the requirements of Table R404.2.3.

R404.2.4 Backfilling. Wood foundation walls shall not be backfilled until the basement floor and first floor have been constructed or the walls have been braced. For crawl space construction, backfill or bracing shall be installed on the interior of the walls prior to placing backfill on the exterior.

R404.2.5 Drainage and dampproofing. Wood foundation basements shall be drained and dampproofed in accordance with Sections R405 and R406, respectively.

R404.2.6 Fastening. Wood structural panel foundation wall sheathing shall be attached to framing in accordance with Table R602.3(l) and Section R402.1.1.

SECTION IB-48. Section R501.1 of Volume IB of the Glendale Building and Safety Code, 2023, is hereby amended to read as follows:

R501.1 Application. The provisions of this chapter shall control the design and construction of the floors for buildings, including the floors of attic spaces used to house mechanical or plumbing fixtures and equipment. Mechanical or plumbing fixtures and equipment shall be attached (or anchored) to the structure in accordance with Section R301.2.2.11.

SECTION IB-49. Section R503.2.4 of Volume IB of the Glendale Building and Safety Code, 2023, is hereby added to read as follows:

R503.2.4 Openings in horizontal diaphragms. Openings in horizontal diaphragms with a dimension perpendicular to the joist that is greater than 4 feet (1.2 m) shall be constructed in accordance with Figure R503.2.4.

SECTION IB-50. Figure R503.2.4 of Volume IB of the Glendale Building and Safety Code, 2023, is hereby added as follows:

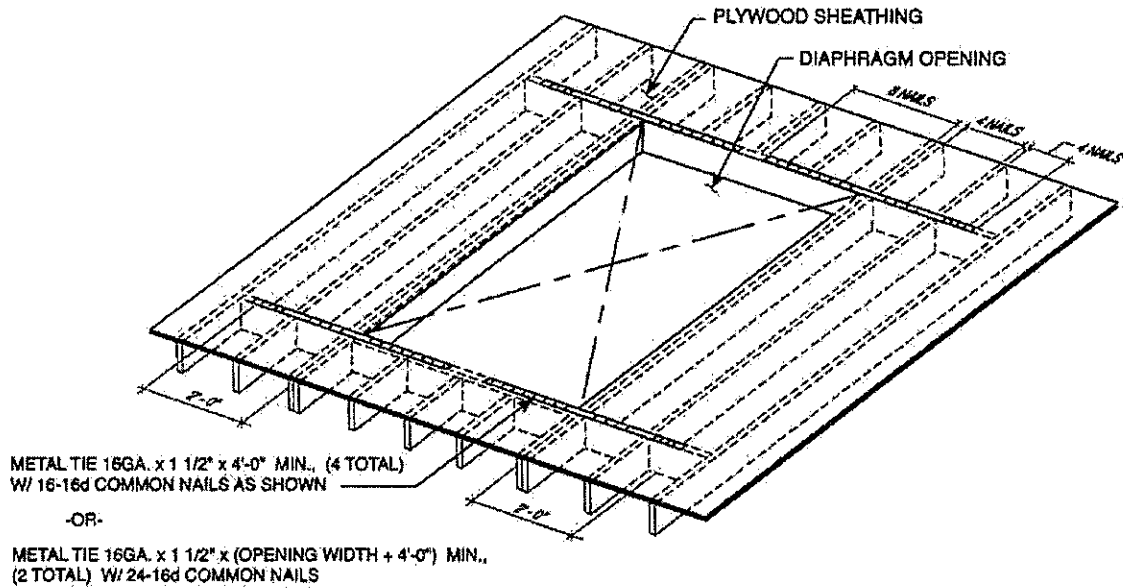

For SI: 1 inch = 25.4 mm, 1 foot = 304.8 mm.

FIGURE R503.2.4

OPENINGS IN HORIZONTAL DIAPHRAGMS

- a. Blockings shall be provided beyond headers.
- b. Metal ties not less than 0.058 inch [1.47 mm (16 galvanized gage)] by 1.5 inches (38 mm) wide with eight 16d common nails on each side of the header-joist intersection. The metal ties shall have a minimum yield of 33,000 psi (227 MPa).
- c. Openings in diaphragms shall be further limited in accordance with Section R301.2.2.2.6.

SECTION IB-51. Section R503.3 of Volume IB of the Glendale Building and Safety Code, 2023, regarding particleboard, is hereby repealed.

SECTION IB-52. Table R602.3(1) of Volume IB of the Glendale Building and Safety Code, 2023, is hereby amended to read as follows:

(TABLE ON FOLLOWING PAGE)

**TABLE R602.3(1)
FASTENING SCHEDULE**

ITEM	DESCRIPTION OF BUILDING ELEMENTS	NUMBER AND TYPE OF FASTENERS ^{a, b, c}	SPACING AND LOCATIONS
Roof			
1	Blocking between ceiling joist, rafters or trusses to top plate or other framing below	4-8d box (2-1/2" x 0.113") or 3-8d common (2-1/2" x 0.131"); or 3-10d box (3" x 0.128"); or 3-3" x 0.131" nails	Toe nail
	Blocking between rafters or truss not at the wall top plates, to rafter or truss	2-8d common (2-1/2" x 0.131"); or 2-3" x 0.131" nails	Each end toe nail
		2-16d common (3-1/2" x 0.162"); or 3-3" x 0.131" nails	End nail
	Flat blocking to truss and web filler	16d common (3-1/2" x 0.162"); or 3" x 0.131" nails	6" o.c. face nail
2	Ceiling joist to top plate	4-8d box (2-1/2" x 0.113") or 3-8d common (2-1/2" x 0.131"); or 3-10d box (3" x 0.128"); or 3-3" x 0.131" nails	Per joist, toe nail
3	<i>Ceiling joist not attached to parallel rafter, laps over partitions (See Section R802.5.2 and Table R802.5.2)</i>	<i>4-10d box (3" x 0.128") or 3-16d common (3-1/2" x 0.162"); or 4-3" x 0.131" nails</i>	<i>Face nail</i>
4	<i>Ceiling joist not attached to parallel rafter (heel joint) (See Section R802.5.2 and Table R802.5.2)</i>	<i>Table R802.5.2</i>	<i>Face nail</i>
5	Collar tie to rafter, face nail	4-10d box (3" x 0.128") or 3-10d common (3" x 0.148"); or 4-3" x 0.131" nails	Face nail each rafter
6	Rafter or roof truss to plate	3-16d box (3-1/2" x 0.135") or 3-10d common (3" x 0.148"); or 4-10d box (3" x 0.128"); or 4-3" x 0.131" nails	2 toe nails on one side and 1 toe nail on opposite side of each rafter or truss
7	Roof rafters to ridge, valley or hip rafters or roof rafter to minimum 2" ridge beam	4-16d box (3-1/2" x 0.135") or 3-10d common (3" x 0.148"); or 4-10d box (3" x 0.128"); or 4-3" x 0.131" nails	Toe nail
		3-16d box (3-1/2" x 0.135") or 2-16d common (3-1/2" x 0.162"); or 3-10d box (3" x 0.128"); or 3-3" x 0.131" nails	End nail
Wall			
8	Stud to stud (not at braced wall panels)	16d common (3-1/2" x 0.162")	24" o.c. face nail
		10d box (3" x 0.128"); or 3" x 0.131" nails	16" o.c. face nail
9	Stud to stud and abutting studs at intersecting wall corners (at braced wall panels)	16d box (3-1/2" x 0.135"); or 3" x 0.131" nails	12" o.c. face nail
		16d common (3-1/2" x 0.162")	16" o.c. face nail
10	Built-up header (2" to 2" header with 1/4" spacer)	16d common (3-1/2" x 0.162")	16" o.c. each edge face nail
		16d box (3-1/2" x 0.135")	12" o.c. each edge face nail
11	Continuous header to stud	5-8d box (2-1/2" x 0.113") or 4-8d common (2-1/2" x 0.131"); or 4-10d box (3" x 0.128"); or	Toe nail
12	Adjacent full-height stud to end of header	4-16d box (3-1/2" x 0.135") or 3-16d common (3-1/2" x 0.162"); or 4-10d box (3" x 0.128"); or 4-3" x 0.131" nails	End nail
13	Top plate to top plate	16d common (3-1/2" x 0.162")	16" o.c. face nail
		10d box (3" x 0.128"); or 3" x 0.131" nails	12" o.c. face nail
14	Double top plate splice	8-16d common (3-1/2" x 0.162") or 12-16d box (3-1/2" x 0.135"); or 12-10d box (3" x 0.128"); or 12-3" x 0.131" nails	Face nail on each side of end joint (minimum 24" lap splice length each side of end joint)

(Continued)

**TABLE R602.3(1) - continued
FASTENING SCHEDULE**

ITEM	DESCRIPTION OF BUILDING ELEMENTS	NUMBER AND TYPE OF FASTENERS ^{a, b, c}	SPACING AND LOCATIONS
Roof			
15	Bottom plate to joist, rim joist, band joist or blocking (not at braced wall panels)	16d common (3-1/2" x 0.162")	16" o.c. face nail
		16d box (3-1/2" x 0.135"); or 3" x 0.131" nails	12" o.c. face nail
16	Bottom plate to joist, rim joist, band joist or blocking (at braced wall panels)	3-16d box (3-1/2" x 0.135") or 2-16d common (3-1/2" x 0.162"); or 4-3" x 0.131" nails	16" o.c. face nail
17	Top of bottom plate to stud	4-8d box (2-1/2" x 0.113") or 3-16d box (3-1/2" x 0.135") or 4-8d common (2-1/2" x 0.131"); or 4-10d box (3" x 0.128"); or 4-3" x 0.131" nails	Toe nail
		3-16d box (3-1/2" x 0.135"); or 2-16d common (3-1/2" x 0.162") or 3-10d box (3" x 0.128"); or 3-3" x 0.131" nails	End nail
18	Top plates, laps at corners and intersections	3-10d common (3" x 0.148"); or 2-16d common (3-1/2" x 0.162") or 3-3" x 0.131" nails	Face nail
19	1" brace to each stud and plate	3-8d box (2-1/2" x 0.113") or 2-8d common (2-1/2" x 0.131"); or 2-10d box (3" x 0.128"); or 2 staples 1-3/4"	Face nail
20 ^c	1" x 6" sheathing to each bearing	3-8d box (2-1/2" x 0.113") or 2-8d common (2-1/2" x 0.131"); or 2-10d box (3" x 0.128"); or 2 staples, 1" crown, 16 ga., 1-3/4" long	Face nail
21 ^b	1" x 8" and wider sheathing to each bearing	3-8d box (2-1/2" x 0.113") or 3-8d common (2-1/2" x 0.131"); or 3-10d box (3" x 0.128"); or 3 staples, 1" crown, 16 ga., 1-3/4" long	Face nail
		Wider than 1" x 8" 4-8d box (2-1/2" x 0.113") or 3-8d common (2-1/2" x 0.131"); or 3-10d box (3" x 0.128"); or 4 staples, 1" crown, 16 ga., 1-3/4" long	
Floor			
22	Joist to sill, top plate or girder	4-8d box (2-1/2" x 0.113") or 3-8d common (2-1/2" x 0.131"); or 3-10d box (3" x 0.128"); or 3-3" x 0.131" nails	Toe nail
23	Rim joist, band joist or blocking to sill or top plate (roof applications also)	4-8d box (2-1/2" x 0.113")	4" o.c. toe nail
		8d common (2-1/2" x 0.131"); or 10d box (3" x 0.128"); or 3" x 0.131" nails	6" o.c. toe nail
24 ^c	1" x 6" subfloor or less to each joist	3-8d box (2-1/2" x 0.113") or 2-8d common (2-1/2" x 0.131"); or 3-10d box (3" x 0.128"); or 2 staples, 1" crown, 16 ga., 1-3/4" long	Face nail

(Continued)

TABLE R602.3(1) - continued
FASTENING SCHEDULE

ITEM	DESCRIPTION OF BUILDING ELEMENTS	NUMBER AND TYPE OF FASTENERS ^{a, b, c}	SPACING AND LOCATIONS	
Roof				
25	2" subfloor to joist or girder	16d box (3-1/2" x 0.135"); or 2-16d common (3-1/2" x 0.162")	Blind and face nail	
26	2" planks (plank & beam – floor & roof)	3-16d box (3-1/2" x 0.135") or 2-16d common (3-1/2" x 0.162")	At each bearing, face nail	
27	Band or rim joist to joist	3-16d common (3-1/2" x 0.162") or 4-10d box (3" x 0.128"); or 4-3" x 0.131" nails; or 4-3 x 14 ga. staples, 7/16" crown	End nail	
28	Band or rim joist to joist	20d common (4" x 0.192"); or 10d box (3" x 0.128"); or 3" x 0.131" nails; or	Nail each layer as follows: 32" o.c. At top and bottom and staggered. 24" o.c. face nail at top and bottom Staggered on opposite sides.	
		And: 2-20d common (4" x 0.192"); or 3-10d box (3" x 0.128"); or 3-3" x 0.131" nails	Face nail at ends and at each splice	
29	Ledger strip supporting joists or rafters	4-16d box (3-1/2" x 0.135") or 3-16d common (3-1/2" x 0.162") or 4-10d box (3" x 0.128"); or 4-3" x 0.131" nails	Face nail at ends and at splice	
30	Bridging or blocking to joist, rafter or truss	2-10d box (3" x 0.128"); or 2-8d common (2-1/2" x 0.131"); or 2-3" x 0.131" nails	Each end, toe nail	
ITEM	DESCRIPTION OF BUILDING ELEMENTS	NUMBER AND TYPE OF FASTENER ^{a, b, c}	SPACING OF FASTENERS	
			Edges (Inches) ^b	Intermediate Supports ^{c, d} (inches)
Wood structural panels, subfloor, roof and interior wall sheathing to framing [see Table R602.3(3) for wood structural panel exterior wall sheathing to wall framing]				
31	3/8" – 1/2"	6d common or deformed (2" x 0.113" x 0.266 head); or 2-3/8" x 0.113 x 0.266" head nail (subfloor, wall) ^f	6	6'
		8d common (2-1/2" x 0.131") nail (roof); or RSRS-01(2-3/8" x 0.113") nail (roof) ^f	6	6'
32	19/32" – 3/4"	8d common (2-1/2" x 0.113") nail (subfloor, wall)	6	12'
		8d common (2-1/2" x 0.131") nail (roof); or RSRS-01; (2-3/8" x 0.113") nail (roof) ^f	6	6'
		Deformed 2-3/8" x 0.113" x 0.266" head (wall or subfloor)	6	12
33	7/8 – 1-1/4	10d common (3" x 0.148") nail; or (2-1/2" x 0.131" x 0.281" head) deformed nail	6	12
Other wall sheathing				
34 ^g	1/2" structural cellululosic fiberboard sheathing	1-1/2" x 0.120" galvanized roofing nail, 7/16" head diameter, or 1-1/4" long 16 ga. staple with 7/16" or 1" crown	3	6
35 ^g	25/32" structural cellululosic fiberboard sheathing	1-3/4" x 0.120" galvanized roofing nail, 7/16" head diameter, or 1-1/2" long 16 ga. Staple with 7/16" or 1" crown	3	6
36 ^g	1/2" gypsum sheathing ^g	1-1/2" x 0.120" galvanized roofing nail; 7/16" head diameter, or 1-1/4" long 16 ga; staple galvanized, 1-1/2" long; 7/16" or 1" crown or 1-1/4" screws, Type W or S	7	7
37 ^g	5/8" gypsum sheathing ^g	1-3/4" galvanized roofing nail; 7/16" head diameter, or 1-1/4" long, 16 ga.; staple galvanized, 1-1/2" long; 7/16" or 1" crown or 1-1/4" screws, Type W or S	7	7
Wood structural panels, combination subfloor underlayment to framing				
38	1/4" and less	6 d deformed (2" x 0.120") nail; or 8d common (2-1/2" x 0.131") nail	6	12
39	7/8" – 1"	8d common (2-1/2" x 0.131") nail; or 8d deformed (2-1/2" x 0.120") nail	6	12
40	1-1/8" – 1-1/4"	10d common (3" x 0.148") nail; or 8d deformed (2-1/2" x 0.120") nail	6	12

For SI: 1 inch = 25.4 mm; 1 foot = 304.8 mm; 1 mile per hour = 0.447 m/s; 1 ksi = 6.895 MPa

(Continued)

TABLE R602.3(1) - continued
FASTENING SCHEDULE

- a. Nails are smooth-common, box or deformed shanks except where otherwise stated. Nails used for framing and sheathing connections are carbon steel and shall have minimum average bending yield strengths as shown: 80 ksi for shank diameter of 0.192 inch (20d common nail), 90 ksi for shank diameters larger than 0.142 inch but not larger than 0.177 inch, and 100 ksi for shank diameters of 0.142 inch or less. Connections using nails and staples of other materials, such as stainless steel, shall be designed by accepted engineering practice or approved under Section R104.11.
- b. RSRS-01 is a Roof Sheathing Ring Shank nail meeting the specifications in ASTM F1667.
- c. Nails shall be spaced at not more than 6 inches on center at all supports where spans are 48 inches or greater.
- d. Four-foot by 8-foot or 4-foot by 9-foot panels shall be applied vertically.
- e. Spacing of fasteners not included in this table shall be based on Table R602.3(2).
- f. For wood structural panel roof sheathing attached to gable end roof framing and to intermediate supports within 48 inches of roof edges and ridges, nails shall be spaced at 4 inches on center where the ultimate design wind speed is less than 130 mph in Exposure B or greater than 110 mph in Exposure C.
- g. Gypsum sheathing shall conform to ASTM C1396 and shall be installed in accordance with ASATM 1280 or GA 253. Fiberboard sheathing shall conform to ASTM C208.
- h. Spacing of fasteners on floor sheathing panel edges applies to panel edges supported by framing members and required blocking and at floor perimeters only. Spacing of fasteners on roof sheathing panel edges applies to panel edges supported by framing members and required blocking. Blocking of roof or floor sheathing panel edges perpendicular to the framing members need not be provided except as required by other provisions of this code. Floor perimeter shall be supported by framing members or solid blocking.
- i. Where a rafter is fastened to an adjacent parallel ceiling joist in accordance with this schedule, provide two toe nails on one side of the rafter and toe nails from the ceiling joist to top plate in accordance with this schedule. The toe nail on the opposite side of the rafter shall not be required.
- j. Use of staples in roof, floor, and braced wall panels shall be prohibited in Seismic Design Category D₀, D₁, or D₂.

SECTION IB-53. Section R602.3.2 of Volume IB of the Glendale Building and Safety Code, 2023, is hereby amended to read as follows:

R602.3.2 Top plate. Wood stud walls shall be capped with a double top plate installed to provide overlapping at corners and intersections with bearing partitions. End joints in top plates shall be offset at least 24 inches (610 mm). Joints in plates need not occur over studs. Plates shall be not less than 2-inches (51 mm) nominal thickness and have a width not less than the width of the studs.

Exception: In other than Seismic Design Category D₀, D₁ or D₂, a single top plate used as an alternative to a double top plate shall comply with the following:

1. The single top plate shall be tied at corners, intersecting walls, and at in-line splices in straight wall lines in accordance with Table R602.3.2.
2. The rafters or joists shall be centered over the studs with a tolerance of not more than 1 inch (25mm).

3. Omission of the top plate is permitted over headers where the headers are adequately tied to adjacent wall sections in accordance with Table R602.3.2.

SECTION IB-54. Table R602.3.2 of Volume IB of the Glendale Building and Safety Code, 2023, is hereby amended to read as follows:

**TABLE R602.3.2
SINGLE TOP-PLATE SPLICE CONNECTION DETAILS**

CONDITION	TOP-PLATE SPLICE LOCATION			
	Corners and intersecting walls		Butt joints in straight walls	
	Splice plate size	Minimum nails each side of joint	Splice plate size	Minimum nails each side of joint
Structures in SDC A-C; and in SDC D_0 , D_1 and D_2 with braced wall line spacing less than 25 feet	3" x 6" x 0.036" galvanized steel plate or equivalent	(6) 8d box (2 1/2" x 0.113") nails	3' x 12" x 0.036" galvanized steel plate or equivalent	(12) 8d box (2 1/2" x 0.113") nails
Structures in SDC D_0 , D_1 and D_2 , with braced wall line spacing greater than or equal to 25 feet	3" x 8" by 0.036" galvanized steel plate or equivalent	(8) 8d box (2 1/2" x 0.113") nails	3' x 16" x 0.036" galvanized steel plate or equivalent	(16) 8d box (2 1/2" x 0.113") nails

For SI: 1 inch = 25.4 mm, 1 foot = 304.8 mm.

SECTION IB-55. Table R602.3(2) of Volume IB of the Glendale Building and Safety Code, 2023, is hereby amended to read as follows:

(TABLE ON FOLLOWING PAGE)

TABLE R602.3(2)
ALTERNATE ATTACHMENTS TO TABLE R602.3(1)

NOMINAL MATERIAL THICKNESS (inches)	DESCRIPTION ^a OF FASTENER AND LENGTH (inches)	SPACING ^c OF FASTENERS	
		Edges (inches)	Intermediate supports (inches)
Wood structural panels, subfloor, roof ^d and wall sheathing to framing and particleboard wall sheathing to framing ^e			
Up to 1/2	Staple 15 ga. 1 3/4	4	8
	0.097 - 0.099 Nail 2 1/4	3	6
19/32 and 5/8	Staple 16 ga. 1 3/4	3	6
	0.113 Nail 2	3	6
23/32 and 3/4	Staple 15 and 16 ga. 2	4	8
	0.097 - 0.099 Nail 2 1/4	4	8
1	Staple 14 ga. 2	4	8
	Staple 15 ga. 1 3/4	3	6
	0.097 - 0.099 Nail 2 1/4	4	8
	Staple 16 ga. 2	4	8
1	Staple 14 ga. 2 1/4	4	8
	0.113 Nail 2 1/4	3	6
	Staple 15 ga. 2 1/4	4	8
	0.097 - 0.099 Nail 2 1/2	4	8
NOMINAL MATERIAL THICKNESS (inches)	DESCRIPTION ^a OF FASTENER AND LENGTH (inches)	SPACING ^c OF FASTENERS	
Floor underlayment; plywood-hardboard-particleboard-fiber-cement ^f			
Fiber-cement			
3/4	3d, corrosion-resistant, ring-shank nails (finished flooring other than tile)	3	6
	Staple 18 ga., 3/8 long, 1/4 crown (finished flooring other than tile)	3	6
	1 1/4 long x .121 shank x .375 head diameter corrosion-resistant (galvanized or stainless steel) roofing nails (for tile finish)	8	8
	1 1/4 long, No. 8 x .375 head diameter, ribbed wafer-head screws (for tile finish)	8	8
Plywood			
1/4 and 5/16	1 1/4 ring or screw shank nail-minimum 12 1/2 ga. (0.099") shank diameter	3	6
	Staple 18 ga., 3/8, 3/16 crown width	2	5
3 1/2, 3/8, 1 1/2, and 1/2	1 1/4 ring or screw shank nail-minimum 12 1/2 ga. (0.099") shank diameter	6	8
2 1/2, 5/8, 2 1/2, and 3/4	1 1/4 ring or screw shank nail-minimum 12 1/2 ga. (0.099") shank diameter	6	8
	Staple 16 ga. 1 1/2	6	8
Hardboard ^g			
0.200	1 1/2 long ring-grooved underlayment nail	6	6
	4d cement-coated sinker nail	6	6
	Staple 18 ga., 3/8 long (plastic coated)	3	6
Particleboard			
1/4	4d ring-grooved underlayment nail	3	6
	Staple 18 ga., 1/2 long, 3/16 crown	3	6
3/8	6d ring-grooved underlayment nail	6	10
	Staple 16 ga., 1 1/4 long, 3/8 crown	3	6
1/2, 5/8	8d ring-grooved underlayment nail	6	10
	Staple 16 ga., 1 1/2 long, 3/8 crown	3	6

(continued)

Notes to Table R602.3(2):

For SI: 1 inch =25.4 mm

- a. Nail is a general description and may be T-head, modified round head or round head.
- b. Staples shall have a minimum crown width of 7/16-inch on diameter except as noted. Use of staples in roof, floor, subfloor, and braced wall panels shall be prohibited in Seismic Design Category D₀, D₁, or D₂.
- c. Nails shall be spaced at not more than 6 inches on center at all supports where spans are 48 inches or greater. Nails shall be spaced at not more than 12 inches on center at intermediate supports for floors.
- d. Fasteners shall be placed in a grid pattern throughout the body of the panel.
- e. For 5-ply panels, intermediate nails shall be spaced not more than 2 inches on center each way.
- f. Hardboard underlayment shall conform to ANSI/AHA A135.4.
- g. Specified alternate attachments for roof sheathing shall be permitted where the ultimate design wind speed is less than 130 mph. fasteners attaching wood structural panel roof sheathing to gable end wall framing shall be installed using the spacing listed for panel edges.
- h. Fiber-cement underlayment shall conform to ASTM C1288 or ISO 8336, Category C.

SECTION IB-56. Section R602.10.2.3 of Volume IB of the Glendale Building and Safety Code, 2023, is hereby amended to read as follows:

R602.10.2.3 Minimum number of braced wall panels. Braced wall lines with a length of 16 feet (4877 mm) or less shall have not less than two braced wall panels of any length or one braced wall panel equal to 48 inches (1219 mm) or more. Braced wall lines greater than 16 feet (4877 mm) shall have not less than two braced wall panels. No braced wall panel shall be less than 48 inches in length in Seismic Design Category D₀, D₁, or D₂.

SECTION IB-57. TABLE R602.10.3(3) of Volume IB of the Glendale Building



and Safety Code, 2023, is hereby amended to read as follows:

TABLE R602.10.3(3)
BRACING REQUIREMENTS BASED ON SEISMIC DESIGN CATEGORY

<ul style="list-style-type: none"> • SOIL CLASS D* • WALL HEIGHT ≤ 10 FEET • 10 PSF FLOOR DEAD LOAD • 15 PSF ROOF/CEILING DEAD LOAD • BRACED WALL LINE SPACING ≤ 25 FEET 			MINIMUM TOTAL LENGTH (FEET) OF BRACED WALL PANELS REQUIRED ALONG EACH BRACED WALL LINE*				
Seismic Design Category	Story Location	Braced Wall Line Length (feet) [†]	Method LIB*	Method GB &	Methods DWB, SFB, PBS, PCP, HPS, CS-SFB* ‡	Method WSP	Methods CS-WSP, CS-G, CS-PF
C (townhouses only)		10	2.5	2.5	2.5	1.6	1.4
		20	5.0	5.0	5.0	3.2	2.7
		30	7.5	7.5	7.5	4.8	4.1
		40	10.0	10.0	10.0	6.4	5.4
		50	12.5	12.5	12.5	8.0	6.8
		10	NP	4.5	4.5	3.0	2.6
		20	NP	9.0	9.0	6.0	5.1
		30	NP	13.5	13.5	9.0	7.7
		40	NP	18.0	18.0	12.0	10.2
		50	NP	22.5	22.5	15.0	12.8
		10	NP	6.0	6.0	4.5	3.8
		20	NP	12.0	12.0	9.0	7.7
		30	NP	18.0	18.0	13.5	11.5
		40	NP	24.0	24.0	18.0	15.3
		50	NP	30.0	30.0	22.5	19.1
D ₀		10	NP	2.8 5.6	2.8 5.6	1.8	1.6
		20	NP	5.5 11.0	5.5 11.0	3.6	3.1
		30	NP	8.2 16.6	8.2 16.6	5.4	4.6
		40	NP	11.0 22.0	11.0 22.0	7.2	6.1
		50	NP	13.8 27.6	13.8 27.6	9.0	7.7
		10	NP	5.3 NP	5.3 NP	3.8	3.2
		20	NP	10.5 NP	10.5 NP	7.5	6.4
		30	NP	15.8 NP	15.8 NP	11.3	9.6
		40	NP	21.0 NP	21.0 NP	15.0	12.8
		50	NP	26.3 NP	26.3 NP	18.8	16.0
		10	NP	7.3 NP	7.3 NP	5.3	4.5
		20	NP	14.5 NP	14.5 NP	10.5	9.0
		30	NP	21.8 NP	21.8 NP	15.8	13.4
		40	NP	29.0 NP	29.0 NP	21.0	17.9
		50	NP	36.3 NP	36.3 NP	26.3	22.3

(continued)

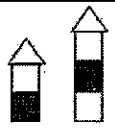
TABLE R602.10.3(3)—continued
BRACING REQUIREMENTS BASED ON SEISMIC DESIGN CATEGORY

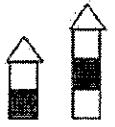
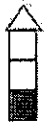
SOIL CLASS D* WALL HEIGHT = 10 FEET 10 PSF FLOOR DEAD LOAD 15 PSF ROOF/CEILING DEAD LOAD BRACED WALL LINE SPACING ≤ 25 FEET		MINIMUM TOTAL LENGTH (FEET) OF BRACED WALL PANELS REQUIRED ALONG EACH BRACED WALL LINE ¹					
Seismic Design Category	Story Location	Braced Wall Line Length (feet) ²	Method LIB ⁴	Method GB ⁵	Methods DWB, SFB, PBS, PCP, HPS, CS-SFB ⁶	Method WSP	Methods CS-WSP, CS-G, CS-PF
D ₁		10	NP	3.0 6.0	3.0 6.0	2.0	1.7
		20	NP	6.0 12.0	6.0 12.0	4.0	3.4
		30	NP	9.0 18.0	9.0 18.0	6.0	5.1
		40	NP	12.0 24.0	12.0 24.0	8.0	6.8
		50	NP	15.0 30.0	15.0 30.0	10.0	8.5
		10	NP	6.0 NP	6.0 NP	4.5	3.8
		20	NP	12.0 NP	12.0 NP	9.0	7.7
		30	NP	18.0 NP	18.0 NP	13.5	11.5
		40	NP	24.0 NP	24.0 NP	18.0	15.3
		50	NP	30.0 NP	30.0 NP	22.5	19.1
		10	NP	8.5 NP	8.5 NP	6.0	5.1
		20	NP	17.0 NP	17.0 NP	12.0	10.2
		30	NP	25.5 NP	25.5 NP	18.0	15.3
		40	NP	34.0 NP	34.0 NP	24.0	20.4
		50	NP	42.5 NP	42.5 NP	30.0	25.5
D ₂		10	NP	4.0 8.0	4.0 8.0	2.5	2.1
		20	NP	8.0 16.0	8.0 16.0	5.0	4.3
		30	NP	12.0 24.0	12.0 24.0	7.5	6.4
		40	NP	16.0 32.0	16.0 32.0	10.0	8.5
		50	NP	20.0 40.0	20.0 40.0	12.5	10.6
		10	NP	7.5 NP	7.5 NP	5.5	4.7
		20	NP	15.0 NP	15.0 NP	11.0	9.4
		30	NP	22.5 NP	22.5 NP	16.5	14.0
		40	NP	30.0 NP	30.0 NP	22.0	18.7
		50	NP	37.5 NP	37.5 NP	27.5	23.4
		10	NP	NP	NP	NP	NP
		20	NP	NP	NP	NP	NP
		30	NP	NP	NP	NP	NP
		40	NP	NP	NP	NP	NP
		50	NP	NP	NP	NP	NP
	Cripple wall below one- or two-story dwelling	10	NP	NP	NP	7.5	6.4
		20	NP	NP	NP	15.0	12.8
		30	NP	NP	NP	22.5	19.1
		40	NP	NP	NP	30.0	25.5
50		NP	NP	NP	37.5	31.9	

For SI: 1 inch = 25.4 mm, 1 foot = 304.8 mm, 1 pound per square foot = 0.0479 kPa.
NP = Not Permitted.

- Linear interpolation shall be permitted.
- Interpolation of bracing length between the S_{DS} values associated with the seismic design categories shall be permitted when a site-specific S_{DS} value is determined in accordance with Section 1613.2 of the *California Building Code*.
- Where the braced wall line length is greater than 50 feet, braced wall lines shall be permitted to be divided into shorter segments having lengths of 50 feet or less, and the amount of bracing within each segment shall be in accordance with this table.
- Method LIB shall have gypsum board fastened to not less than one side with nails or screws in accordance with Table R602.3(1) for exterior sheathing or Table R702.3.5 for interior gypsum board. Spacing of fasteners at panel edges shall not exceed 8 inches.
- Methods PFG and CS-SFB do not apply in Seismic Design Categories D₀, D₁ and D₂.
- Method PFH, PFGH and ABW are only permitted on a single story or a first of two stories.
- Where more than one bracing method is used, mixing methods shall be in accordance with Section R602.10.4.1.
- One- and two-family dwellings in Seismic Design Category D₂ exceeding two stories shall be designed in accordance

with accepted engineering practice.
SECTION IB-58. TABLE R602.10.4 of Volume IB of the Glendale Building





and Safety Code, 2023, is hereby amended to read as follows:

**TABLE R602.10.4
 BRACING METHODS ¹**

METHODS, MATERIAL	MINIMUM THICKNESS	FIGURE	CONNECTION CRITERIA ²	
			Fasteners	Spacing
LIB Let-in-bracing	1 x 4 wood or approved metal straps at 45° to 60° angles for maximum 16" stud spacing		Wood: 2-8d common nails or 3-8d (2 1/2" long x 0.113" dia.) nails	Wood: per stud and top and bottom plates
			Metal strap: per manufacturer	Metal: per manufacturer
DWB Diagonal wood boards	3/4" (1" nominal) for maximum 24" stud spacing		2-8d (2 1/2" long x 0.113" dia.) nails or 2 - 1 1/4" long staples	Per stud
WSP Wood structural panel (See Section R604)	3/8" or 15/32"		8d common (2 1/2" x 0.131") nails Exterior sheathing per Table R602.3(2) 3/8" edge distance to panel edge	6" edges 12" field
			8d common (2 1/2" x 0.131") nails Interior sheathing per Table R602.3(1) or R602.3(2) 3/8" edge distance to panel edge	Varies by fastener 6" edges 12" field
BV-WSP ³ Wood structural panels with stone or masonry veneer (See Section R602.10.6.5)	7/16"	See Figure R602.10.6.5	8d common (2 1/2" x 0.131") nails	4" at panel edges 12" at intermediate supports 4" at braced wall panel end posts
SFB Structural fiberboard sheathing	1/2" or 23/32" for maximum 16" stud spacing		1 1/2" long x 0.12" dia. (for 1/4" thick sheathing) 1 3/4" long x 0.12" dia. (for 23/32" thick sheathing) galvanized roofing nails	3" edges 6" field
GB Gypsum board	1/2"		Nails or screws per Table R602.3(1) for exterior locations	For all braced wall panel locations; 7" edges (including top and bottom plates) 7" field
			Nails or screws per Table R702.3.5 for interior locations	
PBS Particleboard sheathing (See Section R605)	3/8" or 1/2" for maximum 16" stud spacing		For 3/8", 6d common (2" long x 0.113" dia.) nails For 1/2", 8d common (2 1/2" long x 0.131" dia.) nails	3" edges 6" field
PCP Portland cement plaster	See Section R703.7 for maximum 16" stud spacing		1 1/2" long, 11 gage, 7/16" dia. head nails or 7/4" long, 16 gage staples #	6" o.c. on all framing members
HPS Hardboard panel siding	7/16" for maximum 16" stud spacing		0.092" dia., 0.225" dia. head nails with length to accommodate 1 1/2" penetration into studs	4" edges 8" field
ABW Alternate braced wall	3/4"		See Section R602.10.6.1	See Section R602.10.6.1

(continued)

TABLE R602.10.4—continued
BRACING METHODS I

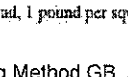
METHODS, MATERIAL		MINIMUM THICKNESS	FIGURE	CONNECTION CRITERIA*	
				Fasteners	Spacing
Intermittent Bracing Methods	PFH Portal frame with hold-downs	$\frac{1}{8}$ "		See Section R602.10.6.2	See Section R602.10.6.2
	PFG Portal frame at garage	$\frac{7}{16}$ "		See Section R602.10.6.3	See Section R602.10.6.3
Continuous Sheathing Methods	CS-WSP Continuously sheathed wood structural panel	$\frac{5}{8}$ " $\frac{15}{32}$ "		8d common (2 1/2" x 0.131) nails 3/8" edge distance to panel edge Exterior sheathing per Table R602.3(3) Interior sheathing per Table R602.3(1) or R602.3(2)	6" edges 12" field Varies by fastener 6" edges 12" field
	CS-G ^h Continuously sheathed wood structural panel adjacent to garage openings	$\frac{5}{8}$ " $\frac{15}{32}$ "		See Method CS-WSP	See Method CS-WSP
	CS-PF Continuously sheathed portal frame	$\frac{7}{16}$ " $\frac{15}{32}$ "		See Section R602.10.6.4	See Section R602.10.6.4
	CS-SFB ¹ Continuously sheathed structural fiberboard	$\frac{1}{2}$ " or $\frac{3}{32}$ " for maximum 16" stud spacing		$1\frac{1}{2}$ " long x 0.12" dia. (for $\frac{1}{2}$ " thick sheathing) $1\frac{3}{4}$ " long x 0.12" dia. (for $\frac{3}{32}$ " thick sheathing) galvanized roofing nails	3" edges 6" field

For SI: 1 inch = 25.4 mm, 1 foot = 304.8 mm, 1 degree = 0.0175 rad, 1 pound per square foot = 47.8 N/m², 1 mile per hour = 0.447 m/s.

- a. Adhesive attachment of wall sheathing, including Method GB, shall not be permitted in Seismic Design Categories C, D0, D1 and D2.
- b. Applies to panels next to garage door opening where supporting gable end wall or roof load only. Shall only be used on one wall of the garage. In Seismic Design Categories D0, D1 and D2, roof covering dead load shall not exceed 3 psf.
- c. Garage openings adjacent to a Method CS-G panel shall be provided with a header in accordance with Table R602.7(1). A full-height clear opening shall not be permitted adjacent to a Method CS-G panel.
- d. Method CS-SFB does not apply in Seismic Design Categories D0, D1 and D2.
- e. Method applies to detached one- and two- family dwellings in Seismic Design Categories D0 through D2 only.
- f. Methods GB and PCP braced wall panel h/w ratio shall not exceed 1:1 in SDC D0, D1 and D2. Methods LIB, DWB, SFB, PBS, HPS, and PFG are not permitted in SDC D0, D1 and D2.
- g. Use of staples in braced wall panels shall be prohibited in SDC D0, D1 and D2.

SECTION IB-59. TABLE R602.10.5 of Volume IA of the Glendale Building and Safety Code, 2023, is hereby amended to read as follows:

**TABLE R602.10.5
MINIMUM LENGTH OF BRACED WALL PANELS**

METHOD (See Table R602.10.4)		MINIMUM LENGTH* (inches)					CONTRIBUTING LENGTH (Inches)
		Wall Height					
		8 feet	9 feet	10 feet	11 feet	12 feet	
DWB, WSP, SFB, PBS, PCP, HPS, BV-WSP		48	48	48	53	58	Actual ^b
GB		48	48	48	53	58	Double sided = Actual Single sided = 0.5 × Actual
LJB		55	62	69	NP	NP	Actual ^b
ABW	SDC A, B and C, ultimate design wind speed < 140 mph	28	32	34	38	42	48
	SDC D ₀ , D ₁ and D ₂ , ultimate design wind speed < 140 mph	32	32	34	NP	NP	
CS-G		24	27	30	33	36	Actual ^b
CS-WSP, CS-SFB	Adjacent clear opening height (inches)						Actual ^b
	≤ 64	24	27	30	33	36	
	68	26	27	30	33	36	
	72	27	27	30	33	36	
	76	30	29	30	33	36	
	80	32	30	30	33	36	
	84	35	32	32	33	36	
	88	38	35	33	33	36	
	92	43	37	35	35	36	
	96	48	41	38	36	36	
	100	—	44	40	38	38	
	104	—	49	43	40	39	
	108	—	54	46	43	41	
	112	—	—	50	45	43	
	116	—	—	55	48	45	
	120	—	—	60	52	48	
	124	—	—	—	56	51	
	128	—	—	—	61	54	
132	—	—	—	66	58		
136	—	—	—	—	62		
140	—	—	—	—	66		
144	—	—	—	—	72		
METHOD (See Table 602.10.4)		Portal header height					
		8 feet	9 feet	10 feet	11 feet	12 feet	
PFH	Supporting roof only	24	24	24	Note c	Note c	48
	Supporting one story and roof	24	24	24	Note c	Note c	
PFG		24	27	30	Note d	Note d	1.5 × Actual ^b
CS-PF	SDC A, B and C	16	18	20	Note e	Note e	1.5 × Actual ^b
	SDC D ₀ , D ₁ and D ₂	24	24	24	Note c	Note c	Actual ^b

For SI: 1 inch = 25.4 mm, 1 foot = 304.8 mm, 1 mile per hour = 0.447 m/s.

NP = Not Permitted.

- Linear interpolation shall be permitted.
- Use the actual length where it is greater than or equal to the minimum length.
- Maximum header height for PFH is 10 feet in accordance with Figure R602.10.6.2, but wall height shall be permitted to be increased to 12 feet with pony wall.
- Maximum header height for PFG is 10 feet in accordance with Figure R602.10.6.3, but wall height shall be permitted to be increased to 12 feet with pony wall.
- Maximum header height for CS-PF is 10 feet in accordance with Figure R602.10.6.4, but wall height shall be permitted to be increased to 12 feet with pony wall.

SECTION IB-60. Figure R602.10.6.1 of Volume IB of the Glendale Building and Safety Code, 2023, is hereby amended to read as follows:

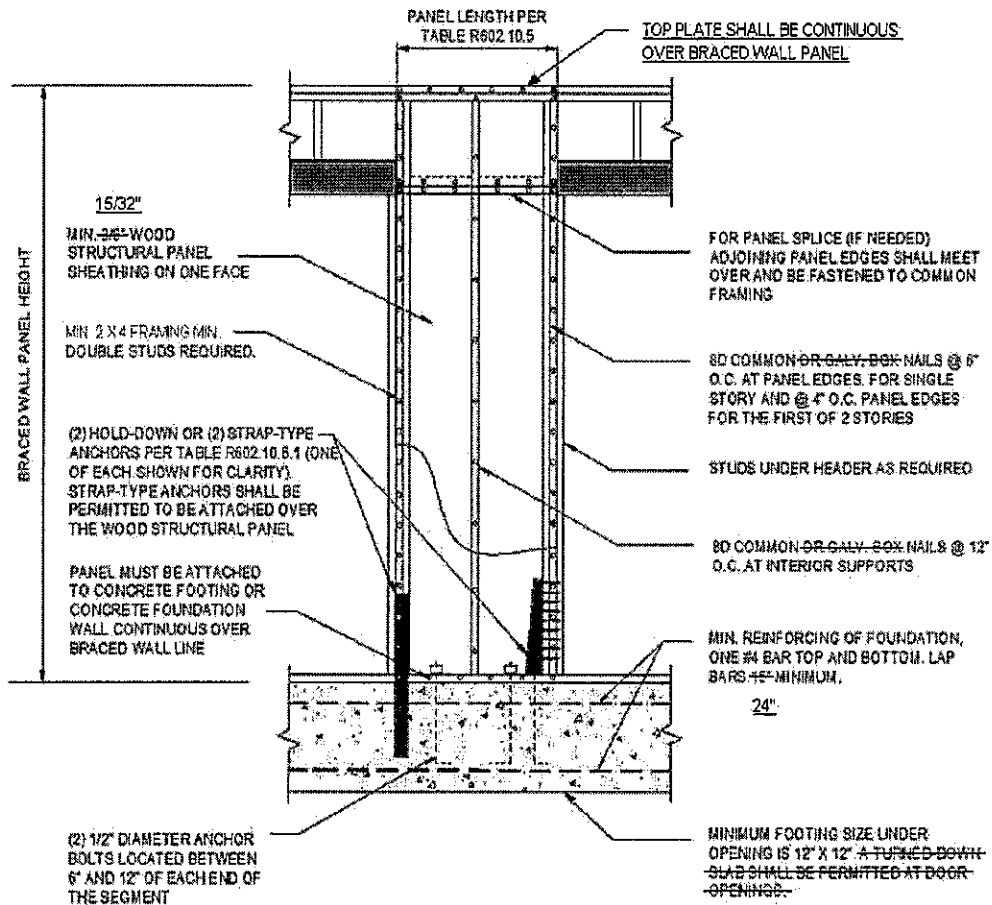

**FIGURE R602.10.6.1
METHOD ABW—ALTERNATE BRACED WALL PANEL**

SECTION IB-61. Figure R602.10.6.2 of Volume IB of the Glendale Building

and Safety Code, 2023, is hereby amended to read as follows:

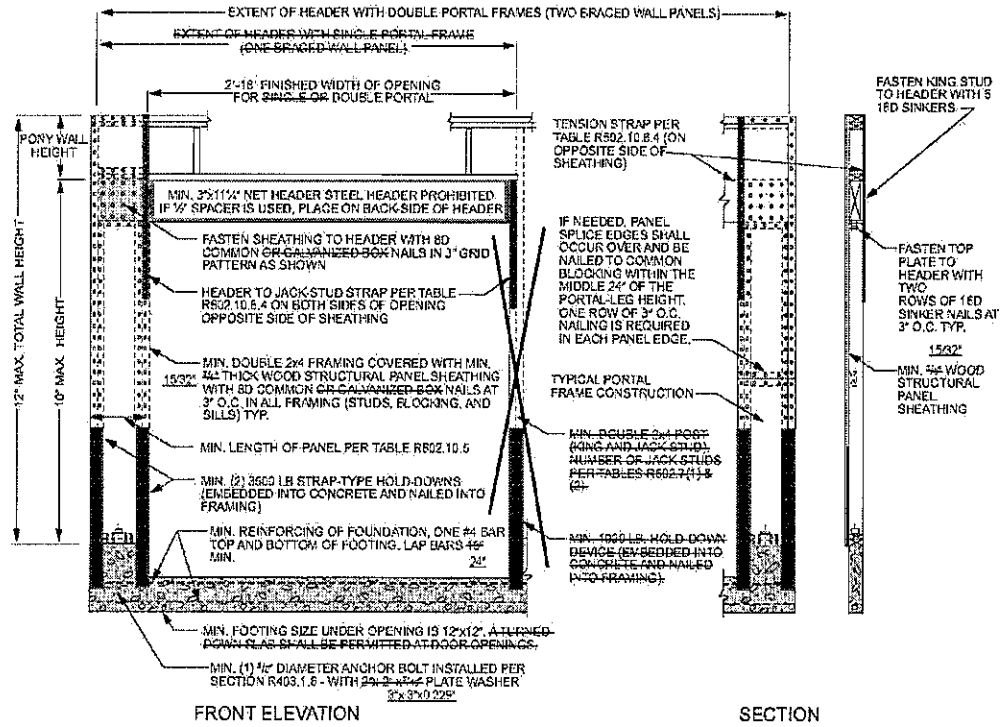

For SI: 1 inch = 25.4 mm, 1 foot = 304.8 mm.

FIGURE R602.10.6.2
METHOD PFH—PORTAL FRAME WITH HOLD-DOWNS
AT DETACHED GARAGE DOOR OPENINGS

SECTION IB-62. Figure R602.10.6.4 of Volume IB of the Glendale Building and Safety Code, 2023, is hereby amended to read as follows:

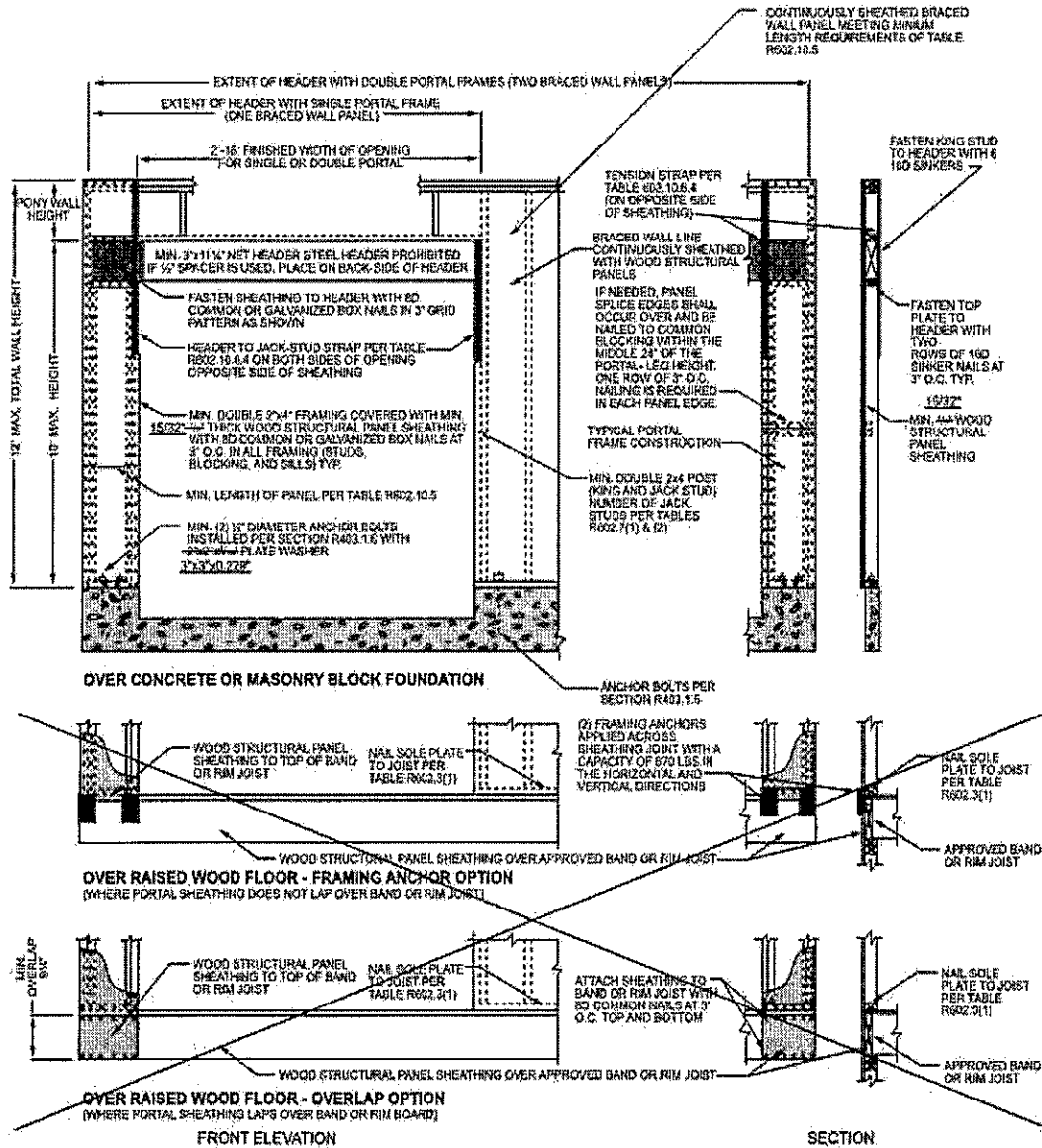

For SI: 1 inch = 25.4 mm, 1 foot = 304.8 mm.

FIGURE R602.10.6.4
METHOD CS-PF—CONTINUOUSLY SHEATHED PORTAL FRAME PANEL CONSTRUCTION

SECTION IB-63. Section R606.4.4 of Volume IB of the Glendale Building and Safety Code, 2023, is hereby amended to read as follows:

R606.4.4 Parapet walls. Unreinforced solid masonry parapet walls shall be not less than 8 inches (203 mm) thick and their height shall not exceed four times their thickness. Unreinforced hollow unit masonry parapet walls shall be not less than 8 inches (203 mm) thick, and their height shall not exceed three times their thickness. Masonry parapet walls in areas subject to wind loads of 30 pounds per square foot (1.44 kPa) or located in Seismic Design Category D₀, D₁ or D₂, or on townhouses in Seismic Design Category C shall be reinforced in accordance with Section R606.12.

SECTION IB-64. Section R606.12.2.2.3 of Volume IB of the Glendale Building and Safety Code, 2023, is hereby amended to read as follows:

R606.12.2.2.3 Reinforcement requirements for masonry elements. Masonry elements listed in Section R606.12.2.2.2 shall be reinforced in either the horizontal or vertical direction as shown in Figure R606.11(2) and in accordance with the following:

1. Horizontal reinforcement. Horizontal joint reinforcement shall consist of not least one No. 4 bar spaced not more than 48 inches (1219 mm). Horizontal reinforcement shall be provided within 16 inches (406 mm) of the top and bottom of these masonry elements.
2. Vertical reinforcement. Vertical reinforcement shall consist not less than one No. 4 bar spaced not more than 48 inches (1219 mm). Vertical reinforcement shall be within 8 inches (203 mm) of the ends of masonry walls.

SECTION IB-65. Section R803.2.4 of Volume IB of the Glendale Building and Safety Code, 2023, is hereby added as follows:

R803.2.4 Openings in horizontal diaphragms. Openings in horizontal diaphragms shall conform with Section R503.2.4.

SECTION IB-66. Section R902.1 of Volume 1B of the Glendale Building and Safety Code, 2023 is hereby amended to read as follows:

R902.1 Roofing covering materials. Roofs shall be covered with materials as set forth in Sections R904 and R905. *A minimum Class A and B roofing shall be installed in areas designated by this section* or where the edge of the roof is less than 3 feet (914 mm) from a lot line. Class A and B roofing required by this section to be listed shall be tested in accordance with UL 790 or ASTM E108. The roof-covering assembly includes the roof deck, underlayment, interlayment, insulation and covering which is assigned a roof covering classification. No wood roof covering material shall be installed. See Section R337 for roofing requirements in Wildland Urban Interface Fire Areas (also known as High Fire Hazard Areas).

Exceptions:

1. Class A roof assemblies include those with coverings of brick, masonry and exposed concrete roof deck.
2. Class A roof assemblies include ferrous or copper shingles or sheets, metal sheets and shingles, clay or concrete roof tile, or slate installed on noncombustible decks.
3. Class A roof assemblies include minimum 16 ounces per square foot copper sheets installed over combustible decks.
4. Class A roof assemblies include slate installed over underlayment over combustible decks.

SECTION IB-67. Section R902.1.2 of Volume 1B of the Glendale Building and Safety Code, 2023, is hereby amended to read as follows:

R902.1.2 Roof coverings in all other areas. *The entire roof covering of every existing structure where more than 50 percent of the total roof area is replaced within any one-year period, the entire roof covering of every new structure, and any roof covering applied in the alteration, repair or replacement of the roof of every existing structure, shall be a fire-retardant roof covering that is at least Class B. No wood roof covering shall be installed.*

SECTION IB-68. Section R902.4 of Volume 1B of the Glendale Building and Safety Code, 2023, is hereby amended to read as follows:

R902.4 Rooftop-mounted photovoltaic (PV) panel systems. Rooftop-mounted photovoltaic (PV) panel systems installed on or above the roof covering shall be tested, listed and identified with a fire classification in accordance with UL 2703. *Listed systems shall be installed in accordance with the manufacturer's installation instructions and their listing.* Class A or B photovoltaic panels and modules shall be installed in jurisdictions designated by law as requiring their use, or where the edge of the roof is less than 3 feet (914 mm) from a lot line.

SECTION IB-69. Section R905.3.7 of Volume 1B of the Glendale Building and Safety Code, 2023, is hereby amended to read as follows:

R905.3.7 Application. Tile shall be applied in accordance with this chapter and the manufacturer's installation instructions, based on the following:

1. Climatic conditions.
2. Roof slope.

3. Underlayment system.
4. Type of tile being installed.

Clay and concrete roof tiles shall be fastened in accordance with this section and the manufacturer's installation instructions. Perimeter tiles shall be fastened with not less than two fasteners per tile. Tiles with installed weight less than 9 pounds per square foot (0.4 kg/m²) require not less than two fasteners per tile regardless of roof slope. Clay and concrete roof tile attachment shall be in accordance with the manufacturer's installation instructions where applied in areas where the ultimate design wind speed exceeds 130 miles per hour (58 m/s) and on buildings where the roof is located more than 40 feet (12 192 mm) above grade. In areas subject to snow, not less than two fasteners per tile are required. In other areas, clay and concrete roof tiles shall be attached in accordance with Table R905.3.7.

SECTION IB-70. Table R905.3.7 of Volume 1B of the Glendale Building and Safety Code, 2023, is hereby amended to read as follows:

**TABLE R905.3.7
CLAY AND CONCRETE TILE ATTACHMENT**

SHEATHING	ROOF SLOPE	NUMBER OF FASTENERS
Solid without battens	All	One Two per tile
Spaced or solid with battens and slope <5:12	Fasteners not required	-
Spaced sheathing without battens	5:12 ≤ slope < 12:12	One Two per tile/every other row
	12:12 ≤ slope < 24:12	One Two per tile

SECTION IB-71. Section R908.7 of Volume IB of the Glendale Building and Safety Code, 2023, is hereby added to read as follows:

R908.7 Roof sheathing. When finish roofing material is removed to the existing space sheathing, a minimum of 3/8 inch (9 mm) thick plywood sheathing shall be installed. See Section R337 for roof coverings permitted in the Wildland Urban Interface Fire Areas (also known as High Fire Hazard Areas). The new sheathing shall comply with the requirements of Section R803. The sheathing shall be installed such that the edges align over rafters and individual spaced sheathing boards. The sheathing shall be attached to the existing spaced sheathing with 6d common nails at 6 inches (147 mm) on center at supported edges and 6d common nails at 12 inches (294 mm) on center at intermediate supports.

SECTION IB-72. Section R918.1.7 of Volume IB of the Glendale Building Code, 2023, is hereby added to read as follows:

R918.1.7 Structural fire-resistance. The structural frame and roof construction supporting the load imposed upon the roof by the photovoltaic panels/modules shall comply with the requirements of Table R302.1(1), R302.1(2) and Table R302.6.

SECTION IB-73. Section R1001.3.1 of Volume IB of the Glendale Building and Safety Code, 2023, is hereby amended to read as follows:

R1001.3.1 Vertical reinforcing. For chimneys up to 40 inches (1016 mm) wide, four No. 4 continuous vertical bars adequately anchored into the concrete foundation shall be placed between wythes of solid masonry or within the cells of hollow unit masonry and grouted in accordance with Section R606. Grout shall be prevented from bonding with the flue liner so that the flue liner is free to move with thermal expansion. For chimneys

more than 40 inches (1016 mm) wide, two additional No. 4 vertical bars adequately anchored into the concrete foundation shall be provided for each additional flue incorporated into the chimney or for each additional 40 inches (1016 mm) in width or fraction thereof.

SECTION IB-74 Appendix AH, PATIO COVERS, of the California Residential Code, 2019 edition, published and copyrighted by the International Code Council is hereby adopted into Volume IB of the Glendale Building and Safety Code, 2023, by reference as further amended herein, into the Glendale Building and safety Code, 2023, and by such reference, is incorporated herein as if fully set forth.

SECTION IB-75. Appendix AH, Section AH105.1 of Volume IB of the Glendale Building and Safety Code, 2023, is hereby amended to read as follows:
AH105.1 Design loads. Patio covers shall be designed and constructed to sustain, within the stress limits of this code, all dead loads plus a vertical live load of not less than 10 pounds per square foot (0.48 IN/m²) except that snow loads shall be used where such snow loads exceed this minimum. Such covers shall be designed to resist the minimum wind loads set forth in Section R301.2.1. Solar energy systems shall not be installed on patio covers designed by this Section.

SECTION IB-76. Appendix Chapter A1 SEISMIC STRENGTHENING PROVISIONS FOR UNREINFORCED MASONRY BEARING WALL BUILDINGS of the CALIFORNIA EXISTING BUILDING CODE is hereby adopted by reference to apply to residential occupancies and to that extent is incorporated into Volume IB of the Glendale Building and Safety Code, 2023.

VOLUME IC. EXISTING BUILDING STANDARDS

SECTION IC-1. Volume IC of the Glendale Building and Safety Code, 2020, is amended as hereinafter provided.

SECTION IC-2. Chapter 1 Division II Section 104.10.2 of Volume IC of the Glendale Building and Safety Code, 2023, is hereby added to read as follows:

104.10.2 Fire code official concurrence. For those cases which may affect fire or life safety in buildings regulated by the State Fire Marshall, the building official shall obtain the concurrence of the fire code official if related to fire protection systems, egress, fire department access or water supply.

SECTION IC-3. Chapter 1 Division II Section 104.11.3 of Volume IC of the Glendale Building and Safety Code, 2023, is hereby added to read as follows:

104.11.3 Fire code official concurrence. For those cases which may affect fire or life safety in buildings regulated by the State Fire Marshall, the building official shall obtain the concurrence of the fire code official if related to fire protection systems, egress, fire department access or water supply.

SECTION IC-4. Chapter 1 Division II Section [A] 105.1 of Volume IA of the Glendale Building and Safety Code, 2023, is hereby amended to read as follows:

[A] 105.1 Permit Required. Any owner or authorized agent who intends to repair, add to, alter, relocate, demolish, or change the occupancy of a building or to repair, install, add, alter, remove, convert, or replace any electrical, gas, mechanical, or plumbing systems, the installation of which is regulated by this code, or to cause any such work to be done, shall first make application to the building official and obtain the required

permit. Parking lots shall not be paved, improved, striped, or restriped unless a separate permit for each parking lot has first been obtained from the building official.

Exception: A separate permit shall not be required to pave, improve, stripe, or restripe a parking lot when such work is included in the scope of another project for which a building permit has been issued and when the design of such parking lot was included in the plan check review of such project.

SECTION IC-5. Chapter 1 Division II Section [A] 105.3 of Volume IC of the Glendale Building and Safety Code, 2023, is hereby amended to read to read as follows:

[A] 105.3 Application for permit. To obtain a permit, the applicant shall first file an application therefor in writing on a form furnished by the Department of Building Safety for that purpose. Such application shall:

1. Identify and describe the work in accordance to Chapter 3 to be covered by the permit for which application is made.
2. Describe the land on which the proposed work is to be done by legal description, street address, or similar description that will readily identify and definitely locate the proposed building or work.
3. Indicate the use and occupancy for which the proposed work is intended.
4. Be accompanied by construction documents and other information as required in Section 106.3.
5. State the valuation of the proposed work.
6. Be signed by the applicant, or the applicant's authorized agent.
7. Give such other data and information as required by the building official.

8. Pay plan review and permit fees as required by this Chapter 1 Division II Volume 1A.

SECTION IC-6. Chapter 1 Division II Section [A] 105.3.2 of Volume IC of the Glendale Building and Safety Code, 2023, is hereby amended to read as follows:

[A] 105.3.2 Time limitation of application. An application for a permit for any proposed work shall be deemed to have been abandoned one-year after the date of filing, unless such application has been pursued in good faith or a permit has been issued; except that the building official is authorized to grant one or more extensions of time for additional periods not exceeding 180 days each. The extension shall be requested in writing and justifiable cause demonstrated.

SECTION IC-7. Chapter 1 Division II Section 105.3.3 of Volume IC of the Glendale Building and Safety Code, 2023, is hereby added to read as follows:

105.3.3 Plan review fees. When submittal documents are required by Chapter 1 Division II, Section 105.3, a plan review fee shall be paid at the time of submitting the submittal documents for plan review. The plan review fees specified in this section are separate fees from the permit fees specified in Chapter 1 Division, Section [A] 108.2 and are in addition to the permit fees. When submittal documents are incomplete or changed so as to require additional plan review, or when the project involves deferred submittal items as defined in Chapter 1 Division II, Section [A] 106.3.4, an additional plan review fee shall be charged at a rate specified by resolution.

SECTION IC-8. Chapter 1 Division II Section [A] 105.5 of Volume IC of the Glendale Building and Safety Code, 2023, is hereby amended to read as follows:

[A] 105.5 Expiration. Every permit issued shall become invalid unless the work on the site authorized by such permit is commenced within 180 days after its issuance, or if the work authorized on the site by such permit is suspended or abandoned for a period of 180 days after the time the work is commenced. Work shall be considered suspended or abandoned if the building official determines that substantial work has not been performed within the time specified above. Substantial work shall be construed to mean:

1. Measurable work such as, but not limited to, the addition of footings, structural members, flooring, wall covering, etc.
2. The work mentioned in subsection 1 of this Section [A] 105.5 above must constitute 20% of the value of the work for which the permit was issued in any 180 day period for Group R, Division 3 occupancies and 10% for all other occupancies.

Before such work can be recommenced, a new permit shall be first obtained to do so, and the fee therefore shall be one half the amount required for a new permit for such work, provided no changes have been made or will be made in the original plans and specifications for such work, and provided further that such suspension or abandonment has not exceeded one year. In order to renew action on a permit after expiration, the permittee shall pay a new permit fee and may be required to comply with all applicable new regulations at the time of issuance. The building official is authorized to grant, in writing, one or more extensions of time, for periods not more than 180 days each. The extension shall be requested in writing and justifiable cause demonstrated.

SECTION IC-9. Chapter 1 Division II Section 105.8 of Volume IC of the Glendale Building and Safety Code, 2023, is hereby added to read as follows:

105.8 Responsibility of permittee. Building permits shall be presumed by the city to incorporate all of the work that the applicant, the applicant's agent, employees and/or contractors shall carry out. Said proposed work shall be in accordance with the approved plans and with all requirements of this code and any other laws or regulations applicable thereto. No city approval shall relieve or exonerate any person from the responsibility of complying with the provisions of this code nor shall any vested rights be created for any work performed in violation of this code.

SECTION IC-10. Chapter 1 Division II Section [A] 106.6 of Volume IC of the Glendale Building and Safety Code, 2023, is hereby amended to read as follows:

[A] 106.6 Design professional in responsible charge. It shall be required that all documents submitted for review the building official shall be prepared by a registered design professional, the code official shall be authorized to require the owner or the owner's authorized agent to engage and designate on the building permit application a registered design professional who shall act as the registered design professional in responsible charge. If the circumstances require, the owner or the owner's authorized agent shall designate a substitute registered design professional in responsible charge who shall perform the duties required of the original registered design professional in responsible charge. The code official shall be notified in writing by the owner or the owner's authorized agent if the registered design professional in responsible charge is changed or is unable to continue to perform the duties. The registered design professional in responsible charge shall be responsible for reviewing and coordinating

submittal documents prepared by others, including phased and deferred submittal items, for compatibility with the design of the building. Where structural observation is required, the inspection program shall name the individual or firms who are to perform structural observation and described the stages of construction at which structural observation is to occur.

Exception: The building official may waive the requirements for a registered design professional when, after reviewing the submitted plans it is determined that the work is minor in nature.

SECTION IC-11. Chapter 1 Division II Section [A] 108.4 of Volume IC of the Glendale Building and Safety Code, 2023, is hereby amended to read as follows:

[A] 108.4 Work commencing before permit issuance. Any person who commences any work before obtaining the necessary permits shall be subject to an additional fee in addition to the normally established permit fee, equal to 100% of such normally established permit fee, or as otherwise determined by the building official.

SECTION IC-12. Chapter 1 Division II Section [A] 109.3.5 of Volume IC of the Glendale Building and Safety Code, 2023, is hereby amended to read as follows:

[A] 109.3.5 Lath and gypsum board inspection. Lath and gypsum board inspections shall be made after lathing and gypsum board, interior and exterior, is in place, but before any plastering is applied or gypsum board joints and fasteners are taped and finished.

Exception: Gypsum board that is not part of a fire-resistance-rated assembly, a shear assembly or a sound transmission control assembly.

SECTION IC-13. Chapter 1 Division II Section 109.3.8.1 of Volume IC of the Glendale Building and Safety Code, 2023, is hereby added to read as follows:

109.3.8.1 Structural observation. For structural observation, see Section 1704 of Volume IA of the Glendale Building and Safety Code, 2020.

SECTION IC-14. Chapter 1 Division II Section 109.7 of Volume IA of the Glendale Building and Safety Code, 2023, is hereby added to read as follows:

109.7 Reinspections. A reinspection fee may be assessed for each inspection or re-inspection when such portion of work for which inspection is called is not complete or when corrections called for are not made.

This section shall not be interpreted as requiring reinspection fees the first time a job is rejected for failure to comply with the requirements of this code, but as controlling the practice of calling for inspections before the job is ready for such inspection or reinspection.

Reinspection fees may be assessed when the approved plans and inspection card are not readily available to the inspector, for failure to provide access on the date for which inspection is requested, or deviation from plans requiring the approval of the Building Official.

To obtain a reinspection, the applicant shall pay the re-inspection fee in accordance with a fee schedule adopted by this jurisdiction.

In instances where reinspection fees have been assessed, no additional inspection of the work will be performed until the required fees have been paid.

SECTION IC-15. Chapter 1 Division II Section R112 and all subsections thereof of Volume IC of the Glendale Building and Safety Code, 2023, is hereby amended to read as follows:

SECTION R112

BUILDING AND FIRE BOARD OF APPEALS

R112.1 General. In order to hear and decide appeals of orders, decisions or determinations made by the building official or the fire code official relative to the application and interpretation of this code, there shall be and is hereby created a joint building and fire board of appeals in accordance with Section 113 of Volume IA of this Code (hereinafter referred to as the "board").

SECTION IC-16. Chapter 1 Division II Section [A] 113.1 of Volume IC of the Glendale Building and Safety Code, 2023, is hereby amended to read as follows:

[A] 113.1 Unlawful acts. It shall be unlawful for any person, firm or corporation to repair, alter, extend, add, move, remove, demolish, or change the occupancy of any building or equipment regulated by this code or cause same to be done in conflict with or in violation of any of the provisions of this code. Maintenance of a building or structure which was unlawful at the time it was constructed and which would be unlawful under this Code if constructed after the effective date of such Code, shall constitute a continuing violation of such Code.

SECTION IC-17. Chapter 1 Division II Section [A] 113.4 of Volume IC of the Glendale Building and Safety Code, 2023, is hereby amended to read as follows:

[A] 113.4 Violation penalties. Any person who violates a provision of this code or fails to comply with any of the requirements thereof or who repairs or alters or changes the occupancy of a building or structure in violation of the approved construction documents or directive of the building official or of a permit or certificate issued under the provisions of this code shall be deemed guilty of a misdemeanor and shall be punishable by a fine of not more than \$1,000.00 or by imprisonment for a term of not more than 6 months, or by both such fine and imprisonment. Such penalty and imprisonment shall not preclude the imposition of any other administrative or judicial civil or criminal remedies under state, federal or local laws.

SECTION IC-18. Chapter 1 Division II Section [A] 114.1 of Volume IC of the Glendale Building and Safety Code, 2023, is hereby amended to read as follows:

[A] 114.1 Authority. Where the building official finds any work regulated by this code being performed in a manner either contrary to the provisions of this code or other laws or ordinances of this jurisdiction or dangerous or unsafe, the building official is authorized to issue a stop work order.

SECTION IC-19. Chapter 1 Division II Section [A] 114.3 of Volume IC of the Glendale Building and Safety Code, 2023, is hereby amended to read as follows:

[A] 114.3 Unlawful continuance. Any person who shall continue any work after having been served with a stop work order, except such work as that person is directed to perform to remove a violation or unsafe condition, shall be guilty of a misdemeanor.

SECTION IC-20. Chapter 1 Division II Section 115.6 of Volume IC of the Glendale Building and Safety Code, 2023, is hereby added to read as follows:

115.6 Non-Compliance. Upon failure to comply with the order within the time specified herein, and if no appeal has been properly and timely filed, the building official shall file in the office of the County Recorder a certificate describing the property and certifying (i) that the building is an unsafe building and (ii) that the owner has been notified.

Whenever the corrections ordered shall thereafter have been completed or the building demolished so that it no longer exists as an unsafe building on the property described in the certificate, the building official shall file a new certificate with the County Recorder certifying that the building has been demolished or all required corrections have been made so that the building is no longer unsafe, whichever is appropriate.

SECTION IC-21. Chapter 1 Division II Section 115.7 of Volume IC of the Glendale Building and Safety Code, 2023, is hereby added to read as follows:

115.7 Vacated Buildings. Any unsafe building ordered vacated in accordance with this section shall not be reoccupied until the unsafe conditions have been eliminated. Each such vacated building shall be locked and otherwise secured against entry and the building official shall post thereon a placard stating: "DO NOT ENTER, UNSAFE TO OCCUPY, CITY OF GLENDALE." Such notice shall remain posted until the required repairs, demolition or removal are completed. Such notice shall not be removed without written permission of the building official and no person shall enter the building except for the purpose of making the required repairs or of demolishing the building.

SECTION IC-22. Chapter 1 Division II Section 118 of Volume IC of the Glendale Building and Safety Code, 2023, is hereby added to read as follows:

SECTION 118

CONSTRUCTION TOILET FACILITIES

118 Temporary Construction Toilets. Toilet Facilities Required. No person shall commence or proceed with the erection, construction, alteration, repair, raising, adding to, removal, or demolition of any building or structure unless adequate, suitable, sanitary toilet facilities under the control of such person are provided for the use of any person employed or working upon such building or structure. Such toilet facilities shall be located upon or within a reasonable distance of the lot, premises, or site upon which such work is being done. In no case shall the line of travel to any facility exceed five hundred feet (500') (153 M). Toilets may not be placed on the public way.

118.1 Toilet Standards. Every toilet shall be of water flush type and shall be connected to a public sewer or private sewage disposal system built in accordance with the provisions of the Plumbing Code. All toilet structures shall be self-closing; the toilet floor shall be smooth, and screened ventilation shall be provided for the toilet compartment. Where workmen are employed during night hours, the toilet building shall be provided with artificial light. In lieu of flush water closets approved chemical toilets may be provided. Toilets may not be located within 10' (3054 mm) of a property line.

SECTION IC-23. Chapter I Division II Section 119 of Volume IC of the Glendale Building and Safety Code, 2023, is hereby added to read as follows:

SECTION 119

ON SITE CONSTRUCTION TRASH AND DEBRIS CONTROL

119 On Site Construction Trash and Debris Control Facilities Required.

No person shall commence or proceed with erection, construction, alteration, repair, raising, adding to, removal, or demolition of any building or structure unless adequate, suitable on site trash and debris control facilities under the control of such person are provided for the use of any person employed or working upon such building or structure. On site trash and debris control shall consist of at least a roll off 523 ft³ (15m³) bin. The container shall be emptied often enough so that no storage of trash is outside the bin. The bin shall be removed from the site after the building has passed final inspection or within thirty (30) days of the expiration of the building permit.

Exception: Additions, less than 900 ft² (84m²), and alterations to Group R, Division 3 occupancies and Group U occupancies need not provide a roll off bin but must store trash and debris in the rear yard in quantities less than 10 ft (3m) wide by 10 ft (3m) long by 4 ft (1.2m) high. All trash and debris whether or not in containers shall be kept 3 ft (912mm) from adjacent property lines.

SECTION IC-24. Chapter 1 Division II Section 120 of Volume IC of the Glendale Building and Safety Code, 2023, is hereby added to read as follows:

SECTION 120

DISASTER REPAIR AND RECONSTRUCTION

120.1 Intent. This section establishes standards and regulations for the expeditious repair and reconstruction of structures damaged as a result of a disaster for which a local emergency has been declared by the City Council. This section does not allow exemptions from the Building, Fire, Electrical, Mechanical, Plumbing, other Codes, or standards.

120.2 Applications of Provisions.

120.2.1 The provisions of this section are applicable following each disaster when a local emergency has been declared by the City Council to all buildings and structures of all occupancies regulated by the City of Glendale. The Council may extend the provisions as necessary.

120.2.2 When approved by the building official, the requirements of this section may be waived in favor of repair recommendations included in an engineering evaluation as defined in Section 120.3.

120.3 Definitions. For the purpose of this section 120, the following definitions apply:

120.3.1 “Architect” means an individual licensed by the State of California to practice architecture as defined in the State of California Business and Professions Code.

120.3.2 “Civil Engineer” means an individual registered by the State of California to civil engineering architecture as defined in the State of California Business and Professions Code.

120.3.3 “Current Code” means the edition of the California Building Code, published by the International Conference of Building Officials, as adopted by the City of Glendale as the Glendale Building and Safety Code, as amended. The edition of said Glendale Building and Safety Code to be applied shall be that edition in effect at the time of the declaration of a local emergency by the City Council.

120.3.4 “Engineering Evaluation” means an evaluation of a damaged building or structure, or suspected damaged building or structure, performed under the direction of a structural engineer, civil engineer, or architect retained by the owner of the building or structure. Engineering evaluations shall, at a minimum, contain recommendations for repair with appropriate opinion of construction cost for those repairs.

120.3.5 “Replacement Value” means the dollar value, as determined by the new building official, of replacing the damaged structure with a new structure of the same size, construction material and occupancy on the same site.

120.3.6 “Structural Engineer” means an individual registered by the State of California to practice structural engineering and to use the title structural engineer as defined in the State of California Business and Professions Code.

120.3.7 “Value of Repair” means the dollar value, as determined by the building official, of making the necessary repairs to the damaged building.

120.4 Repair Criteria.

120.4.1 Abatement of Dangerous Buildings shall be in accordance with the provisions of Chapter 1 Division II, Section 116.

120.4.2 Building and structures of all occupancies which have been damaged as a result of a disaster, except as otherwise noted, shall be repaired in accordance with the following criteria:

1. When the estimated value of repair does not exceed ten percent (10%) of the replacement value of the structure, the damaged portion(s) may be restored to their pre-disaster condition.

Exception: When the damaged elements include suspended ceiling systems, the ceiling system shall be repaired and all bracing required by current code shall be installed.

2. When the estimated value of repair is greater than ten percent (10%) but less than fifty percent (50%) of the replacement value of the structure, the damaged elements, as well as all critical ties, supported elements and supporting elements associated with the damaged elements, shall be repaired and/or brought into conformance with the structural requirements of the current Code.
3. When the estimated value of repair is fifty percent (50%) or more of the replacement value of the structure, the entire structure shall be brought into conformance with the structural requirements of the current Code.

4. In Group R, Division 3 occupancies, the repair value of damaged chimneys shall be excluded from the computation of percentage of replacement value. Damaged chimneys shall be repaired in accordance with Chapter 1 Division II, Section 120.5.

120.5 Repair Criteria for Chimneys.

120.5.1 All damaged chimneys must be repaired or reconstructed to comply with the requirements of Section 2113 of the Glendale Building and Safety Code, 2020. Damaged portions of chimneys shall be removed in accordance with the following criteria:

1. When the damaged portion of the chimney is located between the roof line and the top of the chimney, the damaged portion shall be removed to the roof line provided the roof and ceiling anchorage are in sound condition.
2. For a single-story structure in which the damaged portion of the chimney is below the roof line or the damaged portion extends from above the roof line to below the roof line, the chimney shall be removed to the top of the fire box.
3. For a multi-story structure, the damaged portion of the chimney shall be removed from the top to a floor line where sound anchorage is found.
4. In any structure where the firebox has been damaged, the entire chimney and firebox shall be removed to the foundation. If this foundation is in sound condition, the firebox and chimney may be reconstructed using the existing foundation. If the foundation has been damaged, the foundation shall be removed and replaced.

120.5.2 Where existing conditions preclude the installation of all anchorage required by Section 2113 of the current Code, alternate systems may be used in accordance with the alternate methods and materials provisions of the current Code when approved by the building official. Such alternate systems shall be designed and detailed by a structural engineer, civil engineer, or architect.

120.6 Repair Criteria for Unreinforced Masonry Buildings and Structures.

120.6.1 All buildings as described in Appendix A Chapter A1, Section A102.1 of the California Existing Building Code of Volume IC of the Glendale Building and Safety Code that are damaged shall be repaired and strengthened in accordance with provisions of Chapter 1 Division II, Section 120.4.

120.6.2 Unreinforced masonry buildings damaged less than 50% shall be repaired in accordance with California Existing Building Code, Appendix Chapter A1, Seismic Strengthening Provisions for Unreinforced Masonry Bearing Wall Buildings of Volume IA of this Code.

SECTION IC-25. Chapter 1 Division II Section 121 of Volume IC of the Glendale Building and Safety Code, 2023, is hereby added to read as follows:

SECTION 121

SANDBLASTING

121.1. Sandblasting: Definition. As used in this article, unless the context expressly indicates otherwise, "sandblasting" shall mean the use of air, steam or water containing sand to clean, grind, or cut hard surfaces.

121.2. Dry Sandblasting. Dry sandblasting is prohibited unless authorized by special permission from the building official endorsed upon a permit. Permission for dry sandblasting may be granted only when it is not possible to employ wet sandblasting. When dry sandblasting is permitted, the building official may impose such reasonable and related conditions as he or she may deem necessary for the protection of the public and the adjacent property.

121.3. Use of Canvas. Sandblasting operations shall, at all times, be separated from all adjacent property by canvas or other suitable barrier to prevent the splashing or blowing of water and/or sand thereupon.

121.4. Stoppage of Work. The building official may order the immediate stoppage of sandblasting for failure to comply with any provision of this chapter. Failure of any person to comply immediately with such order shall constitute a misdemeanor.

SECTION IC-26. Section 502.1 of Volume IC of the Glendale Building and Safety Code, 2023, is hereby amended to read as follows:

502.1 General. *[BSC & HCD]* Additions to any building or structure shall comply with the requirements of the *California Building Code or California Residential Code, as applicable*, for new construction. Alterations to the existing building or structure shall be made to ensure that the existing building or structure together with the addition are not less complying to the provisions of the *California Building Code* than the existing building or structure was prior to the addition. An existing building together with its additions shall comply with the height and area provisions of Chapter 5 of the *California Building Code or the height provisions of Chapter 3 of the California Residential Code, as applicable*. Whenever alterations exceed fifty percent (50%) of the replacement value,

as determined by the Building Official, the Building Official may require that all portions of the building be brought up to the standards of the current California Building Code or California Residential Code.

Exception: [BSC] For state-owned buildings, including those owned by the University of California and the California State University and the Judicial Council, the requirements of Section 502.5 are replaced by the requirements of Section 317 through 322.

SECTION IC-27. Section 503.1 of Volume IC of the Glendale Building and Safety Code, 2023, is hereby amended to read as follows:

503.1 General. Alteration to any building or structure shall comply with the requirements of the *California Building Code or California Residential Code, as applicable*, for new construction. Alterations shall be such that the existing building or structure is no less conforming to the provisions of the *California Building Code or California Residential Code*, as applicable, than the existing building or structure was prior to the alteration. Whenever alterations exceed fifty percent (50%) of the replacement value, as determined by the Building Official, the Building Official may require that all portions of the building be brought up to the standards of the current California Building Code or California Residential Code.

Exceptions:

1. An existing stairway shall not be required to comply with the requirements of Section 1011 of the *California Building Code* where the existing space and construction does not allow a reduction in pitch or slope.

2. Handrails otherwise required to comply with Section 1011.11 of the *California Building Code* shall not be required to comply with the requirements of Section 1014.6 of the *California Building Code* regarding full extension of the handrails where such extensions would be hazardous due to plan configuration.
3. Where provided in below-grade transportation stations, existing and new escalators shall have a clear width of less than 32 inches (818mm).
4. *[BCS] For state-owned buildings, including those owned by the University of California and the California State University and the judicial council, the requirements of Section 503.4 are replaced by the requirements of Section 317 through 322.*

SECTION IC-28. Section 505.1 of Volume IC of the Glendale Building and Safety Code, 2023, is hereby amended to read as follows:

505.1 Replacement glass and windows. The installation or replacement of glass or windows shall be required for new installations; and shall comply with the provisions as specified within Chapter 7A of the California Building Code.

SECTION IC-29. Section 1501.6.1 of Volume IC of the Glendale Building and Safety Code, 2023, is hereby amended to read as follows:

[BS] 1501.6.1 Walkways. A walkway shall be provided for pedestrian travel in front of every construction and demolition site unless the applicable governing authority authorizes the sidewalk to be fenced or closed. A walkway shall be provided for pedestrian travel that leads from a building entrance or exit of an occupied structure to a

public way. Walkways shall be of sufficient width to accommodate the pedestrian traffic, but shall not be less than 5 feet (1524 mm) in width. Walkways shall be provided with a durable walking surface and shall be accessible in accordance with *Chapter 11A* or 11B of the *California Building Code*. Walkways shall be designed to support all imposed loads and design live load be less than 150 pounds per square foot (psf) (7.2 kN/m²).

SECTION IC-30. Section 1501.6.7.1 of Volume IC of the Glendale Building and Safety Code, 2023, is hereby added to read as follows:

1501.6.7.1 Shoring. The sidewalk and street shall be protected from caving and settlement by shoring conforming to the safety orders issued by the Division of Occupational Safety and Health, Department of Industrial Relations.

SECTION IC-31. Section 1501.8 of Volume IC of the Glendale Building and Safety Code, 2023, is hereby added to read as follows:

1501.8. Protection of sidewalk excavations. Permits must be secured from the director of public works in accordance with the provisions of the Glendale Municipal Code for making an excavation within a public street, sidewalk, parkway or public property. When any portion of a public sidewalk is to be excavated, the holder of the permit shall construct a substantial temporary walkway not less than five (5) feet (1524 mm) in width for pedestrian travel over the areas to be excavated or around the same.

SECTION IC-32. Section 1501.9 of Volume IC of the Glendale Building and Safety Code, 2023, is hereby added to read as follows:

1501.9. Protection of Obstructions. No person excavating, refilling or obstructing any public sidewalk, street, alley or roadway in the city shall fail or neglect to place barriers at each end and at all necessary places along any such excavations or obstructions to

prevent accidents and no such person shall fail or neglect to display and maintain amber lights from sunset to sunrise at each end and at all necessary places along any such excavation or obstructions run across or substantially across any sidewalk, street, alley, or roadway, such amber lights at such places shall be placed not more than five (5) feet (1524 mm) apart. If, in any case, the director of public works shall designate any particular locations for barriers or require additional light, such barriers or lights shall be placed and maintained at those locations designated. If any permittee fails to perform the duties herein before defined, the director of public works may cause the same to be performed, at the expense of the permittee, or if a deposit has been made pursuant to the Glendale Municipal Code, 1995, then the expense of such performance may be deducted there from to the extent said deposit is sufficient, and if insufficient, then the remaining amount may be charged against the permittee.

SECTION IC-33. Section 1503.4 of Volume IC of the Glendale Building and Safety Code, 2023, is hereby added to read as follows:

1503.4 Street Use Permits

1503.4.1 Permits generally. No person shall use or occupy or obstruct any portion of any sidewalk, street, alley or roadway for storing materials for building purposes, for mixing concrete or mortar, or for any purpose incidental thereto, or for the construction of walkways, fences or canopies in accordance with the provisions of this code, unless a street use permit has been first obtained from the director of public works to do so, and at least one-half of the width of the sidewalk , or a width to be designated by the director of public works of the street, alley or roadway is at all times kept free and clear of all obstructions.

1503.4.2 Street use permit to be posted. The street use permit required by this Section 3308.3 shall at all times during such use, occupancy or obstruction, be conspicuously posted on or near the sidewalk, street, alley or roadway used, occupied or obstructed.

1503.4.3 Term of permit; removal of obstructions. Any permit required by this Section 3308.3 shall be granted for not longer than sixty (60) days. Upon completion of the work, all such obstructions shall be removed, all damages caused thereby repaired and the street and sidewalk restored to their original condition to the satisfaction of the director of public works. If any permittee fails or neglects to so remove, repair and restore within three (3) days after being notified by the director of public works in person or by letter, the director of public works may cause such removal, repairs and restoration to be done at the expense of the permittee.

1503.4.4 Application for street use permits. All applications for street use permits required by this Section 3308.3 shall be in writing and made to the building and safety section and shall be in writing and shall be accompanied by a fee for services provided hereunder which shall be established or modified by resolution of the City Council. The schedule for such fees shall remain on file and be available in the office of the traffic and transportation administrator.

SECTION IC-34. Section 1503.5 of Volume IA of the Glendale Building and Safety Code, 2023, is hereby added to read as follows:

1503.5 Mixing Mortar on Public Property. The mixing or handling of mortar, concrete or other material on public property, when authorized by the director of public works under a street use permit issued under Section 1503.4 of this Code, shall be done in

a mechanical mixer or in a tight box in such a manner as to prevent dripping or splashing on public property.

SECTION IC-35. Appendix Chapter A1, SEISMIC STRENGTHENING PROVISIONS FOR UNREINFORCED MASONRY BEARING WALL BUILDINGS, of the California Existing Building Code, 2022 edition, published and copyrighted by the International Code Council and California Building Standards Commission is hereby adopted into Volume 1C of the Glendale Building and Safety Code, 2023, by reference and by such reference is incorporated herein as if fully set forth.

SECTION IC-36. Appendix Chapter A3, PRESCRIPTIVE PROVISIONS FOR SEISMIC STRENGTHENING OF CRIPPLE WALLS AND SILL PLATE ANCHORAGE OF LIGHT, WOOD-FRAME RESIDENTIAL BUILDINGS, of the California Existing Building Code, 2022 edition, published and copyrighted by the International Code Council and California Building Standards Commission is hereby adopted into Volume 1C of the Glendale Building and Safety Code, 2023, by reference and by such reference is incorporated herein as if fully set forth.

SECTION IC-37. Appendix Chapter A4, EARTHQUAKE RISK REDUCTION IN WOOD-FRAME RESIDENTIAL BUILDINGS WITH SOFT, WEAK OR OPEN FRONT WALLS, of the California Existing Building Code, 2022 edition, published and copyrighted by the International Code Council and California Building Standards Commission is hereby adopted into Volume 1C of the Glendale Building and Safety Code, 2023, by reference and by such reference is incorporated herein as if fully set forth.

SECTION IC-38. Appendix Chapter A5, REFERENCE STANDARDS, of the California Existing Building Code, 2022 edition, published and copyrighted by the International Code Council and California Building Standards Commission is hereby adopted into Volume IC of the Glendale Building and Safety Code, 2023, by reference and by such reference is incorporated herein as if fully set forth.

VOLUME II. PLUMBING STANDARDS

SECTION II-1. Volume II of the Glendale Building and Safety Code, 2023, is amended as hereinafter provided.

SECTION II-2. Chapter 1 Division II Section 104.3.2 of Volume II of the Glendale Building and Safety Code, 2023, is amended to read as follows:

104.3.2 Plan Review Fees. Where a plan or other data is required to be submitted by Section 104.3.1, a plan review fee shall be paid at the time of submitting plans and specifications for review.

The plan review fees for plumbing work shall be at a rate specified by resolution of the City Council.

The plan review fees specified in this subsection are separate fees from the permit fees specified in Section 104.5.

Where plans are incomplete or changed so as to require additional review, an additional fee shall be charged at a rate specified by resolution.

SECTION II-3. Chapter 1 Division II Section 104.5 of Volume II of the Glendale Building and Safety Code, 2023, is amended to read as follows:

104.5 Fees. Fees for permits, investigation, and other fees for services shall be established or modified by resolution of the City Council. The schedule for such fees shall remain on file and be available in the office of the building official. The building official shall review the fees charged for such services at least once annually and shall, with the approval of the City Manager, recommend changes to the Council when the costs for such services make it appropriate.

SECTION II-4. Chapter 1 Division II Section 105.2.6 of Volume II of the Glendale Building and Safety Code, 2023, is hereby amended to read as follows:

105.2.6 Reinspections. A reinspection fee may be assessed for each inspection or reinspection when such portion of work for which inspection is called is not complete or when corrections called for are not made.

This section shall not be interpreted as requiring reinspection fees the first time a job is rejected for failure to comply with the requirements of this code, but as controlling the practice of calling for inspections before the job is ready for such inspection or reinspection.

Reinspection fees may be assessed when the approved plans and inspection card are not readily available to the inspector, for failure to provide access on the date for which inspection is requested, or deviation from plans requiring the approval of the Building Official.

To obtain a reinspection, the applicant shall pay the re-inspection fee in accordance with a fee schedule adopted by this jurisdiction.

In instances where reinspection fees have been assessed, no additional inspection of the work will be performed until the required fees have been paid.

Section II-5. Chapter 1 Division II Section 107.0 of Volume II of the Glendale Building and Safety Code, 2023 is amended to read as follows:

107.0 Building and Fire Board of Appeals.

107.1 General. In order to hear and decide appeals of orders, decisions, or determinations made by the building official or the fire code official relative to the application and interpretations of this code, there shall be and is hereby created a joint

Building and Fire Board of Appeals in accordance with Chapter 1 Division II Section 113 of Volume IA of this Code.

SECTION II-6. Section 815 of Volume II of the Glendale Building and Safety Code, 2023, is hereby added to read as follows:

815. Water Softener Using Dry Wells for Discharge. Water softener systems using dry wells for the discharge of effluents are prohibited.

Exception: Systems with regeneration cycles discharging quantities of total dissolved solids that do not exceed those stipulated in the water quality objectives set by the Regional Water Quality Control Board when approved by the building official.

VOLUME III. MECHANICAL STANDARDS

SECTION III-1. Volume III of the Glendale Building and Safety Code, 2023, is amended as hereinafter provided.

SECTION III-2. Chapter 1 Division II Section 104.3.2 of Volume III of the Glendale Building and Safety Code, 2020, is amended to read as follows:

104.3.2. Plan Review Fees. Where a plan or other data is required to be submitted in accordance with Section 104.3.1, a plan review fee shall be paid at the time of submitting construction documents for review.

The plan review fees for mechanical system work shall be charged at a rate specified by resolution of the City Council. The plan review fees specified in this subsection are separate fees from the permit fees specified in Section 104.5.

Where plans are incomplete or changed so as to require additional plan review, an additional plan review fee shall be charged at a rate specified by resolution of the City Council.

SECTION III-3. Chapter 1 Division II Section 104.5 of Volume III of the Glendale Building and Safety Code, 2023, is hereby amended to read as follows:

104.5 Fees. Fee for permits, investigation and other fees for services shall be established or modified by resolution of the City Council. The schedule for such fees shall remain on file and be available in the office of the building official. The building official shall review the fees at least once annually and shall, with the approval of the City Manager, recommend changes to the council when the costs for such services make it appropriate.

SECTION III-4. Chapter 1 Division II Section 105.2.6 of Volume III of the Glendale Building and Safety Code, 2023, is hereby amended to read as follows:

105.2.6 Reinspections. A reinspection fee may be assessed for each inspection or reinspection when such portion of work for which inspection is called is not complete or when corrections called for are not made.

This section shall not be interpreted as requiring reinspection fees the first time a job is rejected for failure to comply with the requirements of this code, but as controlling the practice of calling for inspections before the job is ready for such inspection or reinspection.

Reinspection fees may be assessed when the approved plans and inspection card are not readily available to the inspector, for failure to provide access on the date for which inspection is requested, or deviation from plans requiring the approval of the Building Official.

To obtain a reinspection, the applicant shall pay the re-inspection fee in accordance with a fee schedule adopted by this jurisdiction.

In instances where reinspection fees have been assessed, no additional inspection of the work will be performed until the required fees have been paid.

SECTION III-5. Chapter 1 Division II Section 107.0 of Volume III of the Glendale Building and Safety Code, 2023, is hereby amended to read as follows:

107.0 Building and Fire Board of Appeals.

107.1. General. In order to hear and decide appeals of orders, decisions or determinations made by the building official or the fire code official relative to the application and interpretations of this code, there shall be and is hereby created a joint

Building and Fire Board of Appeals in accordance with Chapter 1 Division II Section 113
of Volume IA of this Code.

Page intentionally blank

VOLUME IV. ELECTRICAL STANDARDS

SECTION IV-1. Volume IV of the Glendale Building and Safety Code, 2023, is amended as hereinafter provided.

SECTION IV-2. Section 90.10 of Volume IV of the Glendale Building and Safety Code, 2023, is hereby added to read as follows:

90.10 Materials and equipment. All electrical materials, devices, appliances and equipment shall be in conformity with provisions of this Code, and shall be in conformity with approved standards for safety to life and property. Listing, labeling or marking, as conforming to the standards of Underwriters Laboratories, Inc., the American National Standard Institute, Inc., the United States Bureau of Mines, or any nationally recognized testing organization approved by the building official, shall be prima facie evidence of conformity with approved standards for safety to life and property.

(A) Alternate materials and methods of construction. The provisions of this Code are not intended to prevent the use of any material or method of construction not specifically prescribed by this Code, provided any such alternate has been approved as hereinafter provided.

(B) The building official may approve any such alternate provided the building official finds that the material, method, or work offered is for the purpose intended at least the equivalent of that prescribed in this code in quality, strength, effectiveness, durability and safety.

(C) The building official shall require that sufficient evidence be submitted to substantiate any claims that may be made regarding its quality, strength, effectiveness, durability and safety.

SECTION IV-3. Section 90.11 of Volume IV of the Glendale Building and Safety Code, 2023 is hereby added to read as follows:

90.11 Revocation of approval for use. Any approval granted by the building official may be revoked if the electrical materials, devices, or appliances are found to be hazardous to life and property for the purpose used or intended or do not conform with the standards under which said materials, devices, or appliances were approved for use.

SECTION IV-4. Section 90.12 of Volume IV of the Glendale Building and Safety Code, 2023 is added to read as follows:

90.12 Building and Fire Board of Appeals. In order to hear and decide appeals of orders, decisions and determinations made by the building official relative to the application and interpretation of this code, there shall be and is hereby created a joint Building and Fire Board of Appeals in accordance with Chapter 1 Division II, Section 113 of Volume IA of this code.

SECTION IV-5. Article 91 of Volume IV of the Glendale Building and Safety Code, 2020 is added to read as follows:

ARTICLE 91

ENFORCEMENT

91.1. Enforcement.

The provisions of this Section 91.1 shall be as contained in Volume IA of this Code.

91.2. Unsafe Electrical Wiring.

(A) Public Nuisance. Notwithstanding any other provisions of this Code, all electrical service to any electric wiring devices, appliances, or equipment which is found to be dangerous to life or property because they are defective

or improperly installed or used is, for the purpose of this section, unsafe electrical wiring. All such unsafe electrical wiring is hereby declared to be a public nuisance and shall be abated by replacement, repair, or removal in accordance with the procedure specified in subsection (B).

(B) Notice and Order. The building official shall first give a notice and order directed to the owner of record of the building or premises. The notice and order shall be as contained in Chapter 1 Division II Section 116.3 of Volume IA of this Code.

(C) Manner of Giving Notice. The notices required by Section 91.2(B) shall be given in the manner described in Chapter 1 Division Section 116.4 of Volume IA of this Code.

(D) Authority to Disconnect Electric Service. The building official shall have the authority to cut or disconnect any wire in cases of emergency for safety to life or property or where such wire may interfere with the work of the fire department. The building official is hereby authorized to disconnect or order discontinuance of electrical service to any electric wiring devices, appliances or equipment upon expiration of the time fixed by the order of the building official pursuant to subsection (B) of this Section 91.2, when such wiring, device, appliances or equipment is maintained or used in violation of that order.

91.3. Violations and Penalties. Notwithstanding any other provisions of this Code, no person shall install, alter, use or maintain any wiring, devices, appliances or equipment in violation of any of the provisions of this Code. Maintenance of electric wiring, devices,

appliances or equipment which was unlawful at the time altered or installed, and which would be unlawful under this Code if altered or installed after the effective date of this Code shall constitute a continuing violation. Penalties for violating any of the provisions of this Code shall be contained in Chapter 1 Division II Section 114.4 of Volume IA of this Code.

SECTION IV-6. Article 92 of Volume IV of the Glendale Building and Safety Code, 2023, is hereby added to read as follows:

ARTICLE 92

PERMITS AND FEES

92.1. Installation Permit – Required. Notwithstanding any other provisions of this Code, no electric wiring devices, appliances or equipment shall be installed within or on any building, structure or premises nor shall any alteration or addition be made in any such existing wiring, devices, appliances or equipment without first securing a permit therefor from the building official except that no permit shall be required in the following cases:

- (a) The replacement of lamps or the connection of a portable appliance to suitable receptacles which have been permanently installed.
- (b) The installation, alteration or repair of wiring, devices, appliances or equipment for the operation of signals or the transmission of intelligence, where such wiring, devices, appliances or equipment operates at a voltage not exceeding twenty-five volts between conductors, except as otherwise required in this Code.
- (c) The installation, alteration or repair of electric wiring, devices, appliances and

equipment installed by or for a public service corporation, including the Water and Power division of the City, for the use of such a corporation in the generation, transmission, distribution or metering of electrical energy or for the use of such a corporation in the operation of signals or the transmission of intelligence.

- (d) The installation of temporary wiring for testing electrical apparatus or equipment.
- (e) Electric wiring expressly declared to be exempt from the provisions of this article by any other provisions hereof.
- (f) Installation of any portable motor or other portable appliance energized by means of a cord or cable having an attached block end where such cord or cable is permitted by other provisions of this Code.
- (g) Repair of any fixed motor or other appliance, or replacement of the same by another motor or appliance of the same rating and in the same location.
- (h) Christmas tree or similar tree lighting.
- (i) Repair or replacement of current-carrying parts of any switch, contractor or control device.
- (j) Repair of any over current device or lamp holder, or replacement of the same by another over current device or lamp holder of the same rating and in the same location.
- (k) Repair or replacement of electrodes of transformers for signs or marquees.
- (l) Repair or replacement of cords or cables or cord pendants allowed by other provisions of this Code.

- (m) Taping of joints.
- (n) Removal of electric wiring.
- (o) Any similar minor repair or replacement determined by the building official not to involve any hazard to life or property.

The foregoing exemptions from permit requirements shall not be deemed to permit or allow any electric wiring to be done in a manner contrary to other provisions of this Article.

92.2. Application. The provisions of this Section 92.2 shall be as provided in Volume IA of this Code.

92.3. Approval of Deviations. The provisions of this Section 92.3 shall be as provided in Volume IA of this Code.

92.4. Expiration of Permits. The provisions of this Section 92.4 shall be as provided in Volume IA of this Code.

92.5. Fees. The provisions of this Section 92.5 shall be as provided in Volume IA of this Code.

92.6. Used Materials. Previously used materials shall not be reused in any work without written approval obtained in advance from the building official.

92.7. Inspection of Installation - Notice to be Given: Time of Inspection. The provisions of this Section 92.7 shall be as provided in Volume IA of this Code.

92.8. Approval - Generally. The provisions of this Section 92.8 shall be as provided in Volume IA of this Code.

92.9. For Temporary Use. When the building official authorizes the connection and use of temporary wiring, such permission shall be issued to expire at a time to be stated

therein and shall be revocable by the building official if he or she finds that the connection and use of the temporary work is dangerous to life or property or that the work is defective or defectively installed.

92.10. For Parts of Incomplete Installation. Preliminary approval may be granted authorizing the connection and use of certain specified portions of an incomplete installation. Such authorization shall be revocable by the building official if he or she finds that the connection and use of the portion of the incomplete installation are dangerous to life or property or that the portions previously authorized for use are defective or defectively installed.

92.11. Wiring to be Hidden from View. When any part of a wiring installation is to be hidden from view by the permanent placement of parts of the building the person installing the wiring shall notify the building official and such parts of the wiring installations shall not be concealed until they have been inspected and approved by the building official provided that on large installations where the concealment of parts of the wiring proceeds continuously the person installing the wiring shall cause inspections to be made periodically during the progress of the work. The building official shall have the power to remove or require the removal of any obstruction that prevents proper inspection of any electrical equipment.

92.12. Connection of Installation to Power Source Generally - Necessity to meet Requirements. Except where work is done under a maintenance electrician's permit, no person shall make connection from a source of electrical energy or supply electric service to any electric wiring devices, appliances, or equipment for the installation of which a permit is required unless such person shall have obtained satisfactory evidence that such

wiring devices, appliances or equipment is in all respects in conformity with all applicable legal provisions.

92.13. Disconnection and Reconnection to Power Source. No person shall make connections from a source of electrical energy or supply electrical service to any electric wiring devices, appliances or equipment which has been disconnected or ordered to be disconnected by the building official or the use of which has been ordered by the building official to be discontinued until an approval has been obtained from the building official authorizing the reconnection and use of such wiring devices, appliances or equipment. The building official shall notify the serving utility of such order to discontinue use.

SECTION IV-7. Section 690.86 of Volume IV of the Glendale Building and Safety Code, 2023, is hereby added to read as follows:

690.86. Solar photovoltaic panels/modules. Solar photovoltaic panels/modules shall comply with the requirements of this code, Volume IA and Volume IB of the Glendale Building and Safety Code, 2023.

VOLUME V. HOUSING STANDARDS

SECTION V-1. Volume V of the Glendale Building and Safety Code, 2023, is amended as hereinafter provided.

SECTION V-2. Section 203 of Volume V of the Glendale Building and Safety Code, 2023, is hereby amended to read as follows:

SECTION 203

BUILDING AND FIRE BOARD OF APPEALS

203.1. General. In order to hear and decide appeals of orders, decisions or determinations made by the building official relative to the application and interpretations of this Code, there shall be and is hereby created a joint Building and Fire Board of Appeals in accordance with Chapter 1 Division II Section 113 of Volume IA of this Code (hereinafter referred to as the “board”).

203.2. Limitations of Authority. The board shall have no authority relative to interpretation of the administrative provisions of this code and the board shall not be empowered to waive requirements of this code.

SECTION V-3. Section 1101.2 of Volume V of the Glendale Building and Safety Code, 2023, is hereby amended to read as follows:

1101.2. Notice and Order. The building official shall issue a notice and order directed to the record owner of the building. The notice and order shall contain the following:

1. The street address and a legal description sufficient for identification of the premises upon which the building is located.

2. A statement that the building official has found the building to be unsafe, with a brief and concise description of the conditions found to render the building unsafe.
3. A statement of the action required to be taken as determined by the building official.
 - 3.1. If the building official has determined that the building or structure must be repaired, the order shall require that all required permits be secured therefore and the work physically commenced within such time (not to exceed 60 days from the date of the order) and completed within such time as the building official shall determine is reasonable under all of the circumstances.
 - 3.2. If the building official has determined that the building or structure must be vacated, the order shall require that the building or structure shall be vacated within a certain time from the date of the order as determined by the building official to be reasonable.
 - 3.3. If the building official has determined that the building or structure must be demolished, the order shall require that the building be vacated within such time as the building official shall determine reasonable (not to exceed 60 days from the date of the order), that all required permits be secured therefore within 60 days from the date of the order and that the demolition be completed within such time as the building official shall determine is reasonable.

4. Statements advising that if any required repair or demolition work (without vacation also being required) is not commenced within the time specified, the building official will order the building vacated and posted to prevent further occupancy until the work is completed.
5. Statements advising (i) that any person having any record title or legal interest in the building may appeal from the notice and order or any action of the building official to the Building and Fire Board of Appeals, provided the appeal is made in writing as provided in this Code, and filed with the building official within 30 days from the date of service of such notice and order, and (ii) that failure to appeal will constitute a waiver of all right to an administrative hearing and determination of the matter.

VOLUME VI. FIRE STANDARDS

SECTION VI-1. Volume VI of the Glendale Building and Safety Code, 2023, is amended as hereinafter provided.

SECTION VI-2. Chapter 1, Division II, Scope and Administration, of the International Fire Code, 2021 edition published and copyrighted by the International Code Council with amendments of the 2022 California Fire Code is hereby adopted by reference into Volume VI of the Glendale Building and Safety Code, 2023, and by such reference, is incorporated herein as if fully set forth.

SECTION VI-3. Section 103.1 of Volume VI of the Glendale Building and Safety Code, 2023, is hereby added to read as follows:

103.1 Creation of agency. The Glendale Fire Department, Fire Prevention Bureau is hereby created and the official in charge thereof shall be known as the fire code official. The function of the agency shall be the implementation, administration and enforcement of the provision of this code.

SECTION VI-4. Section 104.1.1 of Volume VI of the Glendale Building and Safety Code, 2023, is hereby added to read as follows:

104.1.1 Environmental protection. The Glendale Fire Department is certified by the California Environmental Protection Agency as a Certified Unified Program Agency (CUPA), and is thereby responsible for the implementation and enforcement of regulations and guidelines for the CUPA as described in Section 104.1.1.1. Additionally, the Glendale Fire Department is responsible for the implementation and enforcement of regulations and guidelines for the

Industrial Waste Discharge Program as described in Section 104.1.1.2.

104.1.1.1 CUPA Unified Programs. The following CUPA Programs are included in the scope of the Glendale Fire Department's CUPA authority:

1. Hazardous materials handling, release response plans and inventory Disclosure program (business plans).

2. California Accidental Release Prevention (CalARP) Program.
3. Underground storage tank program pursuant to Health and Safety Code Section 25283 and as that section may be subsequently amended.
4. Aboveground Petroleum Storage Act (APSA) requirements for spill prevention, control and countermeasure (SPCC) plans pursuant to Health and Safety Code Sections 25502(a)(1) and 25404 and as those sections may be subsequently amended.
5. Hazardous waste generator and onsite hazardous waste treatment (tiered permitting) Programs pursuant to Health and Safety Code Sections 25502(a)(1) and 25404 and as those sections may be subsequently amended..
6. California fire code hazardous material management plans and hazardous material inventory statements pursuant to this Volume VI of the Glendale Building and Safety Code, 2020.

104.1.1.1.1 Hazardous Materials Inventory. Regulated facilities in the City of Glendale are required to report quantities of hazardous materials exceeding the permit threshold quantities set forth in the 2020 California Fire Code as amended by the Glendale Municipal Code or State reporting thresholds (e.g. 55 gallons, 500 pounds or 200 scf) California Code, Health and Safety Code § 25507, whichever is less.

104.1.1.1.1.1 Facility Information. Regulated facilities in the City of Glendale are required to report the number of employees, APN number and the property owner name, address and phone number.

104.1.1.2 Industrial waste discharge control program. The Glendale Fire Department is responsible for the implementation and enforcement of regulations and guidelines to govern the discharge of industrial waste to the sanitary sewer and storm drain systems pursuant to Glendale Municipal Code, Chapter 13.40, Article V, and as said chapter may be subsequently amended. For

the purposes of this Volume VI, “Industrial Waste Control Program” means a program to control the discharge of industrial waste to the sanitary sewer system, treatment plant, and/or storm drain system that could interfere with the operations of said systems and could cause blockage and plugging of pipelines and interfere with normal operation of pumps.

SECTION VI-5. Section [A] 105.5 of Volume VI of the Glendale Building and Safety Code, 2023, is hereby amended to read as follows:

[A] 105.6 Required operational permits. The *fire code official* is authorized to issue operational permits for the operations set forth in Sections 105.5 through 105.5.54.

SECTION VI-6. Section 105.6.51 of Volume VI of the Glendale Building and Safety Code, 2023, is hereby added to read as follows:

105.5.55 Additional operational permits. In addition to the permits required by Section 105.6, the following operational permits shall be obtained from the *fire code official*:

1. **General use permit.** A general use permit for any activity or operation not specifically addressed in this article, which in the judgment of the *fire code official*, is possible or likely to produce conditions hazardous to life or property.
2. **Helicopter operations.** Helicopter landing at other than an approved airport, heliport or helistop, or use of a helicopter for the purpose of lifting equipment, supplies or any material.

Exceptions:

1. Filming companies when operating with an approved filming permit;
2. Emergency operations by a governmental agency or other approved agency.
3. **Occupancies, buildings, and uses.** An operational permit is required for various occupancies, buildings, and uses as established or modified by the City Council.

SECTION VI-7. Section [A] 105.6 of Volume VI of the Glendale Building and Safety

Code, 2023, is hereby amended to read as follows:

[A] 105.6 Required construction permits. The fire code official is authorized to issue construction permits for work as set forth in Sections 105.6.1 through 105.6.24.

SECTION VI-8. Section 105.6.25 of Volume VI of the Glendale Building and Safety Code, 2023 is hereby added to read as follows:

105.6.25 Additional construction permits. In addition to the permits required by Section 105.7, the following construction permits shall be obtained from the *fire code official*:

1. Landscaping, irrigation, fuel modification. To install or alter landscaping and irrigation, or to perform fuel modification of hazardous vegetation in the Wildland Urban Interface Fire Areas (also known as High Fire Hazard Areas). See Chapter 49 of this Volume VI of the Glendale Building and Safety Code, 2020.
2. Plan checks and field inspections when required by the *fire code official* and not otherwise addressed in this chapter.

SECTION VI-9. Section 107.7 of Volume VI of the Glendale Building and Safety Code, 2023, is hereby added to read as follows:

107.7 Fees for services. The *fire code official* is authorized to collect fees for services established or modified by resolution of the City Council.

SECTION VI-10. Section 107.8 of Volume VI of the Glendale Building and Safety Code, 2023, is added to read as follows:

107.8 False alarms or nuisance alarms. The *fire code official* is authorized to assess a service charge, as set forth by resolution, against the person owning or responsible for an alarm system when a fire department response occurs as a result of the third *false alarm* or *nuisance alarm* at the same address or location within any twelve month period, and for each subsequent *false alarm* or *nuisance*

alarm thereafter, or against any person who intentionally, or in violation of the law reports, or causes to be reported, a *false alarm* or *nuisance alarm* to any department of the City of Glendale.

SECTION VI-11. Section [A] 111 of Volume VI of the Glendale Building and Safety Code, 2023 is hereby amended to read as follows:

SECTION 111

BUILDING AND FIRE BOARD OF APPEALS

[A] 111.1 Board of appeals established. In order to hear and decide appeals of orders, decisions or determinations made by the *building official* or the *fire code official* relative to the application and interpretation of all volumes of this code, there shall be and is hereby created a joint building and fire board of appeals in accordance with Section 113 of Volume I of this Code (hereinafter referred to as the “board”).

SECTION VI-12. Section [A] 112.4 of Volume VI of the Glendale Building and Safety Code, 2023, is hereby amended to read as follows:

[A] 112.4 Violation penalties. The provisions of this Section shall be as provided in Section 114.4 of Volume I of this Code. With the exception of cost recovery for abatement of public nuisances arising from hazardous vegetation and fuel management which is set forth in Chapter 49 of this Volume VI, the recovery of administrative costs for enforcement of this Code shall be made pursuant to Chapter 2.90 of the Glendale Municipal Code.

SECTION VI-13. Section 202 of Volume VI of the Glendale Building and Safety Code, 2023, is hereby amended to amend the definition of false alarm to read as follows:

FALSE ALARM. The willful and knowing initiation or transmission of a signal, message or other notification of an event of fire when no such danger exists, or the activation of any fire alarm system due to malfunction, mechanical or electrical defect, improper operation or procedure by any person,

or a false oral or written report to any department of the City of Glendale that an emergency exists requiring immediate or emergency response by the Glendale Fire Department.

SECTION VI-14. Chapter 3, GENERAL REQUIREMENTS, of the International Fire Code, 2021 edition published and copyrighted by the International Code Council with amendments of the 2022 California Fire Code is hereby adopted by reference into Volume VI of the Glendale Building and Safety Code, 2023, and by such reference, is incorporated herein as if fully set forth.

SECTION VI-15. Section 307.4.3 of Volume VI of the Glendale Building and Safety Code, 2023, is hereby amended to read as follows:

307.4.3 Portable outdoor fireplaces. Portable outdoor fireplaces shall be used in accordance with the manufacturer's instructions and shall not be operated within 15 feet (4572 mm) of a structure or combustible material.

Exceptions: 1. Portable outdoor fireplaces used at one and two-family dwellings located outside of a wildland-urban interface fire area, when used in accordance with the manufacturer's instructions.

SECTION VI-16. Section 307.4.4 of Volume VI of the Glendale Building and Safety Code, 2023, is hereby added to read as follows:

307.4.4 "Red-flag" and other high fire risk conditions. Open burning, including recreational fires and fires within portable outdoor fireplaces, shall not be permitted when a red-flag warning or a fire weather watch condition has been issued by the National Weather Service.

SECTION VI-17. Section 308.1.5 of Volume VI of the Glendale Building and Safety Code, 2023, is hereby amended to read as follows:

308.1.5 Location near combustibles. Open flames such as from candles, lanterns, kerosene heaters and, gas-fired heaters, barbecues, fire-pits and similar devices shall not be located within a wildland-

urban interface fire area, on or near decorative material, on or near similar combustible materials or within 10 feet (3048 mm) of combustible construction.

Exceptions: 1. Open-flame cooking devices complying with section 308.1.4 of this code shall be permitted provided a minimum separation of 10 feet (3048 mm) from vegetation is maintained.

2. Approved open-flame heating devices shall be permitted for one- and two-family dwellings, provided a minimum separation of 10 feet (3048 mm) from vegetation is maintained.

SECTION VI-18. Section 308.1.9 of Volume VI of the Glendale Building and Safety Code, 2023, is hereby added to read as follows:

308.1.9 Outdoor fires. Outdoor fires shall not be built, ignited or maintained in or upon hazardous fire areas, except by permit from the fire code official.

Exception: Outdoor fires within habited premises or designated campsite where such fires are built in permanent barbecue, portable barbecue, outdoor fire place, incinerator or grill and are a minimum of 30 feet (9144 mm) from grass-, brush-, or tree covered area.

Permits shall incorporate such terms and conditions that will reasonably safeguard public safety and property. Outdoor fires shall not be built, ignited, or maintained in or upon hazardous fire areas under the following conditions:

1. During times when a red-flag warning or a fire weather watch condition has been issued by the National Weather Service;
2. When a person age 17 or older is not present at all times to watch and tend such fire;
3. When a public announcement is made that open burning is prohibited.

Permanent barbecues, portable barbecues, outdoor fireplaces, or grills shall not be used for the disposal of rubbish, trash or combustible waste material.

SECTION VI-19. Section 503, FIRE APPARATUS ACCESS ROADS, of the

International Fire Code, 2021 edition published and copyrighted by the International Code Council with amendments of the 2022 California Fire Code is hereby adopted by reference into Volume VI of the Glendale Building and Safety Code, 2023, and by such reference, is incorporated herein as if fully set forth.

SECTION VI-20. Section 510.3 of Volume VI of the Glendale Building and Safety Code, 2023, is hereby added to read as follows:

510.3 Permit required. A construction permit for the installation of or modification to in building, two-way emergency responder communication coverage systems and related equipment is required as specified in Section 105.6.4. Maintenance performed in accordance with this code is not considered a medication and does not require a permit.

SECTION VI-21. Section 806, NATURAL DECORATIVE VEGETATION IN NEW AND EXISTING BUILDINGS, of the International Fire Code, 2021 edition published and copyrighted by the International Code Council with amendments of the 2022 California Fire Code is hereby adopted by reference into Volume VI of the Glendale Building and Safety Code, 2023, and by such reference, is incorporated herein as if fully set forth.

SECTION VI-22. Section 807, DECORATIVE MATERIALS AND ARTIFICIAL DECORATIVE VEGETATION IN NEW AND EXISTING BUILDINGS, of the International Fire Code, 2021 edition published and copyrighted by the International Code Council with amendments of the 2022 California Fire Code is hereby adopted by reference into Volume VI of the Glendale Building and Safety Code, 2023, and by such reference, is incorporated herein as if fully set forth.

SECTION VI-23. Section 901.1.1 of Volume VI of the Glendale Building and Safety

Code, 2023, is hereby amended to read as follows

901.1.1 Aesthetics. Fire-protection systems and equipment shall be designed with attention given to aesthetics. The fire code official shall be authorized to require changes in design or installation with respect to the aesthetics of any installation upon plan review and upon field inspection and acceptance.

SECTION VI-24. Section 901.6 of Volume VI of the Glendale Building and Safety Code, 2023, is hereby amended to read as follows:

901.6 Inspection, testing and maintenance. Fire detection and alarm systems, emergency alarm systems, gas detection systems, fire extinguishing systems, mechanical smoke exhaust systems, and smoke and heat vents, critical equipment, fire rated assemblies, egress system components, and related equipment and appurtenances shall be maintained in an operative condition at all times, and shall be replaced or repaired where defective. The fire code official is authorized to require periodic inspection, testing and certification of all such systems, equipment and appurtenances. Personnel and concerns shall be qualified to perform the inspection, testing, and certification in accordance with Table 901.6. In addition to provisions of the applicable test standards, the required certifications shall be provided to the fire code official upon request and transmitted to the fire code official at least annually unless otherwise specified in Table 901.6. The fire code official shall stipulate the approved manner and method of transmitting certification reports by means of a policy. Nonrequired fire protection systems and equipment shall be inspected, tested and maintained as for required systems, or removed with approval of the fire code official.

All fire alarm systems, fire detection systems, automatic sprinkler or extinguishing systems, communication systems, and all other equipment, material or systems required by these regulations shall be maintained in an operable condition at all times in accordance with this code and California

Code of Regulations, Title 19, Division 1. Upon disruption or diminishment of the fire protective qualities of such equipment, material or systems, immediate action shall be instituted to effect a reestablishment of such equipment, material or systems to their original normal and operational condition.

SECTION VI-25. Table 901.6 of Volume VI of the Glendale Building and Safety Code, 2023, is hereby added to read as follows:

TABLE 901.6 REQUIRED TESTING, TESTER QUALIFICATIONS, AND CERTIFICATION SUBMITTAL INTERVALS

	TESTER QUALIFICATIONS (a)	REQUIRED MINIMUM TESTING FREQUENCIES (b)				FREQUENCY TO SUBMIT REPORTS TO GLENDALE FIRE DEPT (c)	HOW TO SUBMIT TO GLENDALE FIRE DEPT
		Semi-annual	Annual	Triennial	Every 5 years		
Engineered Fixed Extinguishing System	Dry Chemical	1, 5	X			Annually	Online – The Compliance Engine (d)
	Carbon Dioxide	1, 5		X		Annually	Online – The Compliance Engine (d)
	Halogenated	1, 5	X			Annually	Online – The Compliance Engine (d)
	Clean Agent	1, 5		X		Annually	Online – The Compliance Engine (d)
	Wet Chemical	1, 5	X			Annually	Online – The Compliance Engine (d)
Standpipe Systems	1, 5		X		X	Annually	Online – The Compliance Engine (d)
Automatic Fire Sprinkler Systems	1, 5		X		X	Annually	Online – The Compliance Engine (d)
Pressure Reducing Valves	1, 5		X			Annually	Online – The Compliance Engine (d)
Water Storage Tanks	1, 5				X	Every Five Years	Online – The Compliance Engine (d)
Fire Pumps	1, 5	Electric-monthly Diesel-weekly	X			Annually	Online – The Compliance Engine (d)
Fire Alarm / Monitoring Systems	8	Frequency ranges from quarterly to annually depending upon equipment; see NFPA 72				Annually	Online – The Compliance Engine (d)
Commercial Cooking Equipment	Fire Protection Systems	1, 5	X			Annually	Online – The Compliance Engine (d)
	Duct Cleaning	Frequency ranges from 1 month to 12 months; see NFPA 96				Not required	
Private Fire Hydrants	1, 9		X			Annually	Online – The Compliance Engine (d)
Single Station Smoke Alarms	2, 6		X			Annually	Mail-in certificate (e)
Fire Extinguishers	5		X			Annually	Mail-in certificate (e)
Emergency and Standby Power	2		X			Annually	Online – The Compliance Engine (d)
Smoke Management System	3		X			Annually	Online – The Compliance Engine (d)
Automatic Closing Assemblies	4, 7		X			Annually	Online – The Compliance Engine (d)
Fire Escapes	7, 10		X			Annually	Online – The Compliance Engine (d)
Emergency Responder Radio Coverage Systems	11		X			Annually	Online – The Compliance Engine (d)

a. Other concerns or individuals may be qualified to test and certify subject to approval of the fire code official.

b. The testing frequencies listed herein are intended as a convenient summary based on the applicable standards. The applicable standards shall always govern if there is any conflict. It is important to note that many standards mandate inspections on more frequent bases than shown herein. It is not the intent to supersede, modify, or reduce the requirements found in the applicable standards.

- c. Reports of tests and certifications need not be submitted to the Glendale Fire Department more frequently than annually, unless specifically requested by the fire code official.
- d. *The Glendale Fire Department contracts with a third company, The Compliance Engine, and requires contractors submit all test and certification reports online through that service. www.thecomplianceengine.com*
- e. *Mail-in certificate of these items is permitted on a GFD form or contractor's form.*
 - 1. State Licensed Fire Protection Contractor (C-16) holding the U.L. Certificate (or approved equal) for the building fire alarm system
 - 2. State Licensed Electrical Contractor (C-10)
 - 3. State Licensed HVAC Contractor (C-20) LAFD Regulation 4 Certified Concern
 - 4. May be performed by Owner License (GROL) and certification by an approved school,
 - 5. Licensed by the State Fire Marshal
 - 6. Qualified owner may perform test other than mid-rise and high-rise buildings
 - 7. State Licensed General Contractor (A or B); see also footnote (a)
 - 8. State Licensed Electrical Contractor (C-10) and, for systems installed after 1989,
 - 9. State Licensed Plumbing Contractor (C-36)
 - 10. For this item only, GFD will consider an
 - 11. FCC-issued General Radio Operators organization, or the equipment manufacturer

SECTION VI-26. Section 901.11 of Volume VI of the Glendale Building and Safety

Code, 2023, is hereby added to read as follows:

901.11 Critical equipment.

901.11.1 Definitions. Critical Equipment. Such mechanical and electrical equipment necessary for the operation of life safety systems, or any other equipment needed to meet the fire and life safety requirements of a building. Examples of critical equipment include, but are not limited to, emergency generator systems, smoke control systems, fire pumps, etc.

901.11.2 Locations. Critical equipment shall be located as close as practical to the ground floor, but not be located on floors above the ground floor.

Exceptions:

- 1. Equipment that by function must be located above the ground floor.
- 2. When approved by the fire code official.

901.11.3 Supervision. All critical equipment shall be provided with a means of supervision, including electronic supervision, lockouts, and other means as approved by the fire code official.

901.10.4 Ventilation. When the proper operation of critical equipment is dependent upon ventilation, the ventilation system shall be so arranged as to ensure continuous reliable operation.

Ducts shall be provided within rated shafts without fire or smoke dampers that may impact equipment operation.

901.11.5 Signage and graphics.

901.11.5.1 General. Critical equipment in buildings shall be identified with permanent signage indicating the equipment is critical for fire and life safety, identify the system and component appropriately, and any other pertinent information such as contacting the building engineer prior to servicing, lock-out/tag-out procedures, etc. Signage shall be approved by the fire code official.

901.11.5.2 Shut-offs. All service disconnects, circuit breakers, control valves, or other means of disconnection shall be identified with signage in accordance with Section 901.11.5.1

901.11.5.3 System graphics. Custom made, permanent system graphics shall be provided which show the system in schematic, identifying main component locations, a narrative system description, matrix of operations, and any other pertinent notes and instructions for firefighters. The graphics shall be specifically designed for responding firefighting and inspections. Additional information may be required to accommodate routine maintenance and testing personnel. All graphics shall be approved by the fire code official.

SECTION VI-27. Section 903.2.21 of Volume VI of the Glendale Building and Safety Code, 2023, regarding where automatic sprinkler systems are required, is hereby added to read as follows:

903.2.21 Where required. Notwithstanding other provisions of the code, *approved automatic sprinkler systems* in new and existing buildings and structures shall be provided in accordance with this section.

Exceptions:

1. When approved by the fire code official, spaces or areas in telecommunications buildings used exclusively for telecommunication equipment, associated electrical power distribution equipment, batteries and standby engines, provided those spaces or areas are equipped throughout with an automatic fire alarm system and are separated from the remainder of the building by fire barriers consisting of not less than one-hour fire-resistance-rated walls and two-hour fire-resistance-rated floor/ceiling assemblies.

2. *Automatic fire sprinkler protection for fixed guideway transit systems shall comply with*

Section 903.2.21.17.

903.2.21.1 New occupancies. An automatic sprinkler system shall be installed in all new occupancies.

Exceptions:

1. Group B, Group F Divisions 1 and 2, and Group M occupancies, less than 1000 total square feet (92.9 m²).
2. Group S Division 1 occupancies not classified as motor vehicle repair garages less than 1000 total square feet (92.9 m²).
3. Group S Division 2 occupancies not classified as parking garages less than 1000 total square feet (92.9 m²).
4. Canopies over motor vehicle fuel dispensers not attached to a structure provided they are sufficiently separated on all sides from real or imaginary property lines and other structures so as not to require opening protection.
5. Group S Division 2 occupancies classified as open parking garages and not subject to California Fire Code section 903.2.10.1, commercial parking garages. **903.2.21.2**

Existing occupancies. An automatic sprinkler system shall be installed and maintained in all existing occupancies as follows:

1. Throughout existing and new sections of any existing building whenever total additions result in an increase of more than 1000 square feet (92.9 m²) in the total floor area, including mezzanines or additional stories, regardless of ownership. Additions shall be cumulative with each application for building permit within the previous five years.

Exception: Group R, Division 3 occupancies.

2. Throughout existing and new sections of any existing building whenever alterations exceed fifty percent (50%) of the replacement value, as determined by the building official. Alteration values shall be cumulative with each application for a building permit within the previous five years.

Exception: Expenditures for tenant improvements, maintenance and repairs such as interior and exterior painting, carpeting, interior window coverings, drapes, movable partitions, surface re-roofing or plumbing, mechanical and electrical repairs.

3. Throughout existing and new sections of any existing building for which there is an occupancy classification change to a more hazardous use, as determined by the fire code official or building official.
4. Throughout any existing Group R Division 2 occupancy being subdivided to condominium units.
5. Existing high-rise buildings. "Existing high-rise buildings," as defined in Volume I shall have an automatic sprinkler system installed and operational throughout.
6. Existing mid-rise buildings. Existing mid-rise buildings shall have an automatic fire sprinkler system installed and operational throughout. For the purpose of this section, "mid-rise building" means any building six or more stories in height or more than 55 feet (16,764 mm) in height and not defined as a high-rise building. Measurement shall

be from the underside of the roof or floor above the topmost occupiable space to the lowest fire apparatus access road level or building access, whichever is lower.

Exception: Open parking garages.

7. Existing low-rise building. Existing low-rise buildings shall have an automatic fire sprinkler system installed and operational throughout. For the purpose of this section, “low-rise building” means any building four or more stories in height but less than 55 feet (16,764 mm) in height from the lowest level of Fire Department access.

Measurement shall be from the underside of the roof or floor above the topmost occupiable space to the lowest fire apparatus access road level or building access, whichever is lower.

Exception: Open parking garages.

903.2.21.2.1 Notification, recordation, enforcement, and standards.

Notification, recordation, enforcement and standards addressed in this Section 903.2.21.2.1 shall be enforced by the fire code official to ensure compliance with Section 903.2.21.2, subsections 6, 7, and 8.

1. Notification. Whenever, pursuant to Section 903.2.21.2, the fire code official determines by inspection that a building does not conform to the minimum requirements of Section 903.2.21.2, subsection 6, 7 or 8, the fire code official shall prepare a fire/life safety notice in writing that the building be repaired and modified to conform to the minimum requirements of said Sections. The notice shall specify in what manner the building fails to meet the minimum requirements of Section 903.2.21.2, subsection 6, 7, or 8. It shall direct that plans be submitted, and that necessary permits be obtained not later than one (1) year after the service of the notice, and that necessary corrections be completed not later than three (3)

years thereafter for work required under Section 903.2.21.2, subsection 6, not later than four (4) years thereafter for work required under Section 903.2.21.2, subsection 7 and not later than five (5) years thereafter for work required under Section 903.2.21.2, subsection 8. The notice shall be transmitted by the fire code official for enforcement purposes. The fire code official shall serve the notice either personally or by certified or registered mail upon the owner as shown on the last equalized assessment roll and upon the person, if any, in real or apparent charge or control of the building. The provisions of this Section 903.2.21.2.1 are not intended to prevent the fire code official from also making a determination or issuing an order regarding failure to comply with Section 903.2.21.2, subsection 6, 7, or 8.

2. Recordation. At the time that the fire code official serves the aforementioned order or notice, the fire code official shall file with the Office of the County Recorder, a certificate stating that the subject building does not meet the minimum fire safety requirements of Section 903.2.21.2, subsection 6, 7, or 8 and that the owner thereof has been so notified. After all necessary corrective work has been performed; the fire code official shall file with the Office of the County Recorder, a certificate terminating the status of the subject building as nonconforming to the minimum fire safety requirements of Section 903.2.21.2, subsection 6, 7, or 8.
3. Enforcement. If the owner or other person in charge and control of the subject building fails to comply with the aforementioned order or notice within the time periods set forth in Section 903.2.21.2.1, such person is guilty of a misdemeanor punishable by a fine or by imprisonment or both. A person is guilty of a separate offense each day during which he or she commits, continues or permits a violation of Section 903.2.21.2, subsection 6, 7, or 8. The fire code official shall also order that the building owner or other person in charge and

control post a notice of non-conformance. The notice shall be placed in a conspicuous area of the building until all required corrective work has been completed.

SECTION VI-27. Section 906.8 of Volume VI of the Glendale Building and Safety Code, 2023 is hereby amended to read as follows:

906.8 Cabinets. Cabinets used to house portable fire extinguishers shall not be locked.

Exceptions:

1. Where portable fire extinguishers subject to malicious use or damage are provided with a means of ready access.
2. In Group I-3 occupancies and in mental health areas in Group I-2 occupancies, access to portable fire extinguishers shall be permitted to be locked or to be located in staff locations provided the staff has keys.

In new construction, fire extinguishers shall be located within recessed or semi-recessed cabinets. In existing occupancies, fire extinguishers shall be located within recessed or semi-recessed cabinets when required by the fire code official. Cabinets should be mounted at no higher than four feet (1219 mm) above the floor to the top of the cabinet. Fire extinguishers shall be mounted with the brackets or hangers within the cabinets.

Exception: Surface mounted cabinets may be installed when construction material makes recessing the cabinet impracticable.

SECTION VI-28. Section 906.9.1 of Volume VI of the Glendale Building and Safety Code, 2023, is hereby amended to read as follows:

906.9.1 Extinguishers weighing 40 pounds or less. Portable fire extinguishers having a gross weight not exceeding 40 pounds (18kg) shall be installed so that their tops are not more than 48 inches (1219 mm) above the floor.

SECTION VI-29. Section 907.6.6 of Volume VI of the Glendale Building and Safety Code, 2020, is hereby amended to read as follows:

907.6.6 Monitoring. Fire alarm systems required by this chapter or by the *California Building Code* shall be monitored by an approved central station service system in accordance with NFPA 72 Section 26.3 *and this section.*

Exception: Monitoring by a supervising station is not required for

1. Single- and multiple-station smoke alarms required by Section 907.2.11.
2. Group I-3 occupancies *shall be monitored in accordance with Section 907.2.6.3.*
3. *Automatic sprinkler systems* in one-and two-family dwellings.

SECTION VI-30. Section 907.11 of Volume VI of the Glendale Building and Safety Code, 2023, is hereby added to read as follows:

907.11 Certification and Identification of Certificated Systems.

907.11.1 New Systems. All new fire alarm systems shall maintain a valid Certificate as required by NFPA 72 Section 26.3 for the life of the system. The permittee and the listed contractor issuing the Certificate shall be one and the same.

907.11.2 Existing systems. The fire code official is authorized to order existing systems to provide central station service system monitoring if no monitoring exists, or upgrade existing monitoring to central station service system monitoring, in accordance with the provisions of Section 907.6.6 as amended, and this Section, when any one of the following conditions occur:

1. Systems produce three or more false or nuisance alarm activations within a 12-month period.
2. Systems become unmaintainable or unreliable due to dilapidation or deterioration as determined by the fire code official.

3. Upon replacement of the fire alarm control unit, or when 25% or more of the devices are replaced.
4. A change in occupancy occurs to a more hazardous use as determined by the fire code official.

Exception: Group R Division 3 occupancies.

SECTION VI-31. Section 1033 Volume VI of the Glendale Building and Safety Code, 2023, and by such reference, is incorporated herein as if fully set forth.

1033 Special egress graphics.

1033.1 General. When required by the fire code official, a special egress graphics package shall be incorporated into new and existing structures. Such structures may include parking structures, warehouses, high-rise buildings, mid-rise buildings, complex projects, or when required by the fire code official. The package may include one or more of the following.

1. Oversized exit identification. Signs or graphics shall be provided to assist in identification of exits, and shall be so designed and installed so as to be visible to occupants from a distance of not less than 300 feet (91,440 mm).
2. Supplemental egress graphics. Supplemental egress graphics shall be provided to assist in the orderly and safe evacuation or relocation of people. Such graphics shall be performance based and include way-finding to identify egress paths and termination points.
3. Special egress graphics - finishes. Means of egress shall be painted and / or constructed with or otherwise finished with materials as per the Building Code or as otherwise approved by the fire code official.

SECTION VI-32. Section 1103.2 of Volume VI of the Glendale Building and Safety

Code, 2023, is hereby added to read as follows:

Section 1103.2 Emergency responder communication coverage in existing buildings.

Existing buildings other than Group R-3, that do not have approved in-building, two-way emergency response communication coverage for emergency responders in the building based on existing coverage for emergency responders in the building based on existing coverage levels of the public safety communication system, shall be equipped with such coverage according to one of the following:

1. Where an existing wired communication system cannot be repaired or is being replaced, or where not approved in accordance with Section 510.1 Exception 1.
2. Within a time frame established by the adopting authority.

Exception: where it is determined by the fire code official that the in-building, two-way emergency responder communication coverage system is not needed.

SECTION VI-33. Section 1103.3 of Volume VI of the Glendale Building and Safety Code, 2023, is hereby added to read as follows

Section 1103.3 Existing elevators, In other than Group R-3 existing elevators, escalators and moving walk shall comply with the requirements in Sections 1103.1 and 1103.3.3.

SECTION VI-34. Section 1104 of Volume VI of the Glendale Building and Safety Code, 2023, is hereby added to read as follows

Section 1104 Means of egress for existing buildings, of the International Fire Code, 2021 edition published and copyrighted by the International Code Council with amendments of the 2022 California Fire Code is hereby adopted by reference into Volume VI of the Glendale Building and Safety Code, 2023, and by such reference, is incorporated herein as if fully set forth

SECTION VI-35. Section 4902.1 of Volume VI of the Glendale Building and Safety Code, 2023, is hereby amended to add the following definitions as follows:

4901.3 Liability for damage

4901.3 Liability for damage. The expense of fighting fire that results from a violation of this chapter shall be charged against the person whose violation of this chapter caused the fire.

Damages caused by such fires shall constitute a debt of such person and are collectable by the fire code official in the same manner as in the case of an obligation under contract expressed or implied.

4902.1 General.

DEFENSIBLE SPACE. That space within 100 feet (30 480 mm) of a building or structure where vegetation capable of causing a fire to spread must be modified to slow the rate and intensity of an advancing wildfire to provide access by fire and other emergency personnel to defend the building or structure from the threat of fire.

HAZARDOUS VEGETATION. Refuse, grass, weeds, shrubs, trees, or other vegetation which, in the opinion of the fire code official, are in such condition and location, or by the unique characteristics of a species, as to provide a ready fuel supply to augment the spread or intensity of a fire.

4907.1 General.

4907.1 General. Hazardous vegetation and fuels shall be managed to reduce the severity of potential exterior wildfire exposure to buildings and to reduce the risk of fire spreading to buildings as required by applicable laws and regulations. Hazardous vegetation or refuse shall be abated, and all grass, weeds, shrubs, and trees shall be properly maintained so as to not create a fire hazard within the community, while maintaining sufficient vegetation for aesthetic and soil erosion control purposes. Maintenance shall occur on a year-round basis to ensure the removal

and/or proper maintenance of grass, weeds, shrubs, trees and refuse in order to prevent the spread or intensity of fire within the community and to ensure adequate “defensible space” in the urban/wildland interface area of the city, referred to as the Wildland Urban Interface Fire Areas (also known as the Very High Fire Hazard Severity Zone).

4906.3 Requirements.

4906.3 Requirements. Hazardous vegetation and fuels around all applicable buildings and structures shall be maintained in accordance with the following laws and regulations. Nothing contained in this section shall be deemed to preclude the fire code official from requiring more than the minimum specific requirements set forth herein when the fire code official determines that conditions exist that necessitates greater fire protection measures.

1. Public Resources Code, Section 4291.
2. California Code of Regulations, Title 14, Division 1.5, Chapter 7, Subchapter 3, Section 1299 (see guidance for implementation “General Guideline to Create Defensible Space”).
3. California Government Code, Section 51182.
4. California Code of Regulations, Title 19, Division 1, Chapter 7, Subchapter 1, Section 3.07.
5. Glendale Fire Department Fire Prevention Bureau “Vegetation Management Program (VMP) Defensible Space Guidelines”.

4907.4 Specific requirements.

4907.4.1 Roads. Maintain trees and hazardous vegetation within 10 feet (3048 mm) of that portion of a highway, street, alley, or driveway which is improved or used for vehicle travel or other vehicular purposes that the fire code official determines as used for access or egress.

4907.4.2 Cut vegetation and refuse. Remove and/or safely dispose of all cut vegetation and

hazardous refuse. Cut grass may be left on the slope to protect the soil if it lays down within three (3) inches (76 mm) of the ground. Cut vegetation may be chipped or mulched and left on the slope up to a depth of 12 inches (305 mm).

4907.4.3 Soil erosion control. If the abatement of hazardous vegetation results in the exposure of bare mineral soil, or the soil is exposed to such an extent that increased soil erosion would be likely, or the fire code official determines that the abatement has been excessive and poses a threat to the public health, safety or welfare, suitable erosion control measures must be provided to establish effective soil erosion control to the satisfaction of the fire code official.

4907.5 Enforcement.

4907.5.1 **Public Nuisance, Inspection Process.** The Council finds that hazardous vegetation prohibited under Section 4907 increases the danger of fire and thus constitutes a public nuisance. If such condition exists, the fire code official shall give written notice to the owner of record and a copy of said notice to any other person with possessory interest in the property, to abate the nuisance within 30 days from the date the notice was sent. The notice shall be sent by certified mail and shall state that the owner is required to abate the nuisance and that if the nuisance is not abated, the city may take further action which may include but is not limited to the following actions: (1) the city, or its contractor, may enter upon the parcel of land and remove or otherwise eliminate or abate the nuisance, (2) upon completion of such work the cost thereof, including administrative costs, shall become a special assessment against that parcel, and (3) upon city council confirmation of the assessment and recordation of said notice, a lien shall attach to the parcel to be collected on the next regular property tax bill levied against the parcel.

4907.5.2 **Commencement of abatement proceeding.** Whenever the fire code official determines that a public nuisance exists, and following mailing of the notice under Section 4907.5, the abatement proceedings shall commence.

4907.5.3 **Abatement proceeding--service of notice of city's intent to abate a public nuisance.** In the event the owner or any other person with possessory interest in the property fails to abate hazardous vegetation pursuant to notice given under Section 4907.5, the fire code official shall notify the owner of record of the affected property as shown on the latest equalized tax assessment roll, by certified mail, that the city intends to abate the public nuisance. A copy of said notice shall also be mailed to any other person with possessory interest in the property. Said notice shall be sent not less than 15 days prior to the date of the city's proposed abatement. The fire code official shall also post a copy of said notice in a conspicuous location on the property. Failure of any owner or other party having possessory interest in the property to receive a notice hereunder, shall not affect the validity of said notice nor any proceeding taken hereunder, provided that the procedure for service of notice has been followed. The notice of intention shall be in substantially the following form:

**NOTICE OF INTENTION
TO ABATE PUBLIC NUISANCE**

(Name and address of owner of the land)

"As owner shown on the last equalized assessment roll of the land located at (address), you are hereby notified that the undersigned, pursuant to the Glendale Building and Safety Code, Volume VI, Section 4907 determined that there exists upon said land or building the following condition which constitutes a public nuisance pursuant to the provisions of the Glendale Building and Safety Code, Volume VI, Section 4907.

"You are hereby notified to abate said nuisance within 15 days from the date of mailing of this notice, and upon your failure to do so, the same will be abated by whatever action necessary by the city and the costs thereof, together with administrative costs, assessed to you as owner of the land on which said public nuisance is located.

"As owner of the land on which said public nuisance is located, you are hereby notified that you may, within 10 days after the mailing of this notice of intention, request in writing to the fire code official a public hearing to contest the finding of the public nuisance on said property. If such a request is not received by the fire code official within such 10-day period, the fire code official shall have the authority to abate said public nuisance and assess the costs as aforesaid without a public hearing. You may submit a sworn written statement within such 10-day period setting forth your position and intentions regarding the public nuisance on said property with your reasons for denial and such statement shall be construed as a request for hearing at which your presence is not required. You may appear in person at any hearing requested by you or, in lieu thereof, may present a sworn written statement aforesaid in time for consideration at such hearing."

Notice Mailed

(Date)

s/

Fire Chief

4907.5.4 Appeals. The owner of the substandard property may appeal the finding of the fire code official by submitting within a ten (10) day period from the date of the mailing of the Notice, to the fire code official, a written request for a hearing before the Building and Fire Board of Appeals. Appeals under this section shall be held before the Building and Fire Board

of Appeals, which shall hear all facts and testimony it deems pertinent. The facts and testimony may include testimony on the condition of the property and circumstances related to the nuisance. The owner of the land may appear in person at the hearing or present a sworn written statement in time for consideration at the hearing. The Building and Fire Board of Appeals may impose such conditions and take such other action as it deems appropriate to carry out the purpose of the provisions of this section. The decision of the Building and Fire Board of Appeals may be appealed to the city council pursuant to the Uniform Appeals Procedure, Chapter 2.88, Glendale Municipal Code.

4907.5.5 Procedure. If any order of the Building and Fire Board of Appeals made pursuant to Section 4907 is not complied with within the period designated by the Board, the fire code official may then cause such work to be done to the extent necessary to eliminate the public nuisance and other substandard conditions determined to exist by the Board and the cost of such work shall be assessed to the property as set forth in California Government Code Section 38773.5 and as that section may subsequently be amended.

4907.5.6 Emergency procedures. Notwithstanding any other provision in Section 4907, when in the opinion of the fire code official, a substandard structure or substandard property is an immediate hazard to life and property, and the fire code official makes written findings to the effect that abatement of such hazard requires action, the fire code official may then cause such work to be done to the extent necessary to eliminate the hazard. The fire code official shall attempt to contact the property owner, to the extent possible, to inform the owner of the work to be done and request said owner's assistance or immediate voluntary removal of the hazard. At the time or shortly thereafter the work is performed, the fire code official shall post a notice and mail to the property owner a statement of the nature of the work performed. Any individual aggrieved by the action of the fire code official under this section, may appeal the determination

of the action to the Building and Fire Board of Appeals as set forth in Section 4907.5.4 except that the appeal shall be filed within ten (10) days from the date of mailing the notice of work performed.

4907.5.7 Costs. The costs involved in the correction of substandard conditions in any action to abate a nuisance shall be charged against the owner of the property. In addition to the above costs, an administrative processing fee established by resolution of the council of the City of Glendale, shall be assessed against each parcel for fire department costs associated with abatement. The fire code official shall review the fees at least once annually, and shall recommend changes to the council when the costs for the services make it appropriate. The fire code official shall notify all parties concerned by certified mail as to the amount of such assessment resulting from such work. If the total assessment determined as provided for in this section is not paid within thirty (30) days after mailing of such notice, such charges shall be placed as a special assessment on the tax bill for the property pursuant to the procedure set forth in Section 38773.5 of the California Government Code and as that section by subsequently be amended. If applicable, an award of attorney's fees to a prevailing party shall also be assessed.

4907.5.8 Recording of notice of special assessment lien. After performing any hazard abatement work or taking any actions to correct substandard conditions, the fire code official shall cause to be recorded with the County Recorder a "Notice of Special Assessment Lien." Such notice shall summarize the work performed, the cost and date of completion.

4907.5.9 Collection of costs by lien not exclusive remedy. The Council declares that it is the intent of the City of Glendale to collect costs charged against the city after performing any public nuisance or hazard abatement work or correcting substandard conditions by lien or any other legal remedies.

4907.5.9.1 Owner costs. Re-inspection and administrative fees to ascertain code compliance for overdue abatement of previously noticed or cited violations shall be charged against the owner.

4907.5.9.2 Notice of public hearing on lien. If the amount of such expenses as shown in such statement is not paid to the fire code official within thirty (30) days after such notice, the fire code official shall prepare a written notice to the owner of the property upon which the city intends to file a lien. Upon preparation of such notice, the fire code official shall present same to the city council, and the city council shall forthwith, by resolution, fix a time and place for a public hearing on such notice. The fire code official shall cause a copy of such notice to be served on the owner of the property not less than ten (10) days prior to the time fixed for such hearing. Mailing a copy of such notice to the owner of the property at the address listed in the most recent property ownership records provided to the city by the County Assessor as of the date the fire code official causes notice to be sent by certified mail and shall comprise proper service. Service shall be deemed complete at the time of deposit in the United States mail. At the public hearing as scheduled above, the city council will hear all noticed or affected property owners who would be obligated to pay the abatement and related costs incurred by the city. The city council shall confirm the appropriateness of persons to be held responsible for the noticed abatement charges and report to the fire code official its final determinations of liability concerning the affected parties. Charges confirmed by the city council and not paid within five (5) days of the public hearing date will be subject to lien and collection procedures.

4907.5.9.3 Recording of lien. The fire code official shall record in the Office of the County Recorder of the County of Los Angeles, State of California, a certificate substantially in the following form:

“NOTICE OF SPECIAL ASSESSMENT LIEN”

Pursuant to authority vested in me by the Glendale Building and Safety Code, I did on the day of _____, _____, cause a condition to be abated or chargeable action to occur on the hereinafter-described real property at the expenses of the owner thereof, in the amount of \$ _____. Said amount has not been paid nor any part thereof, and the City of Glendale does hereby claim a lien upon the hereinafter-described real property in said amount. The same shall be a lien upon the said real property until said sum, with interest thereon from the date of recordation of this lien in the office of the County Recorder of the County of Los Angeles, State of California, and such other charges as may be set by resolution of the city council, has been paid in full. The real property hereinabove mentioned and upon which a lien is claimed is that certain parcel of land lying and being in the City of Glendale, County of Los Angeles, State of California, and particularly described as follows:

Assessor's Parcel Number _____

Dated this _____ day of _____, _____.

Fire Chief, City of Glendale

4907.5.10 Method of collection. With the confirmation of the report by the city council, the hazard abatement charges contained therein that remain unpaid by the owner of the subject property shall constitute a special assessment against said property as it has received the special benefit of city abatement services. The same shall be a lien against the property described therein until the amount.

SECTION VI-36. Section 5707 of Volume VI of the Glendale Building and Safety Code, 2023, is hereby added to read as follows

Section 5707, ON-DEMAND MOBILE FUELING OPERATIONS, of the International Fire Code, 2021 edition published and copyrighted by the International Code Council with amendments of the 2022 California Fire Code is hereby adopted by reference into Volume VI of the Glendale Building and Safety Code, 2023, and by such reference, is incorporated herein as if fully set forth.

SECTION VI-37. Appendix B Table B105.2 of Volume VI of the Glendale Building and Safety Code, 2023, is hereby amended to read as follows:

**TABLE B105.2
REQUIRED FIRE FLOW FOR BUILDINGS OTHER THAN ONE- AND TWO-FAMILY DWELLINGS, GROUP R-3 AND R-4 BUILDINGS AND TOWNHOUSES**

AUTOMATIC SPRINKLER SYSTEM (Design Standard)	MINIMUM FIRE FLOW (gallons per minute)	FLOW DURATION (hours)
No automatic sprinkler system	Value in Table B105.1(2)	Duration in Table B105.1(2)
Section 903.3.1.1 of the <i>California Fire Code</i>	Up to 50% of the value in Table B105.1(2) as approved ^a	Duration in Table B105.1(2) at the reduced flow rate

For SI: 1 gallon per minute = 3.785 L/min

a. The reduced fire flow shall be not less than ~~1,000~~ 1,500 gallons per minute.

SECTION VI-38. Section 5707 of Volume VI of the Glendale Building and Safety Code, 2023, is hereby added to read as follows.

TABLE C102.1—REQUIRED NUMBER AND SPACING OF FIRE HYDRANTS ^f

FIRE-FLOW REQUIREMENT (gpm)	MINIMUM NUMBER OF HYDRANTS	AVERAGE SPACING BETWEEN HYDRANTS ^{b, c} (feet)	MAXIMUM DISTANCE FROM ANY POINT ON STREET OR ROAD FRONTAGE TO A HYDRANT ^d

1,750 or less	1	300	250
1,751 – 2, 250	2	300	225
2,251 – 2,750	3	300	225
2,751 – 3,250	3	300	225
3,251 – 4,000	4	300 ^a	210
4,001 – 5,000	5	300 ^a	180
5,001 – 5,500	6	300 ^a	180
5,501 – 6,000	6	250 ^a	150
6,001 – 7,000	7	250 ^a	150
7,001 or more	8 more ^c	250 ^a	120

For SI: 1 foot = 304.8 mm, 1 gallon per minute = 3.785 L/min

- a. Reduce by 100 feet for dead-end streets or roads.
- b. Where streets are provided with median dividers which cannot be crossed by firefighters pulling hose lines, or arterial streets are provided with four or more traffic lanes and have a traffic count of more than 30,000 vehicles per day, hydrant spacing shall average 500 feet on each side of the street and be arranged on an alternating basis.
- c. Where new water mains are extended along streets where hydrants are not needed for protection of structures or similar fire problems, fire hydrants shall be provided at not less than 1,000-feet to provide for transportation hazards.
- d. Reduce by 50 feet for dead-end streets or roads.
- e. One hydrant for each 1,000 gallons per minute or fraction thereof.
- f. The fire code official is authorized to modify the location, number and distribution of the fire hydrants based on site-specific constraints and hazards.

SECTION VI-39. Appendix D, fire apparatus access roads, of the California Fire Code edition, published and copyrighted by the International Code Council, are hereby adopted by reference into Volume VI of the Glendale Building and Safety Code, 2023, and by such reference, are incorporated herein as if fully set forth.

SECTION VI-40. Appendix D107 of Volume VI of the Glendale Building and Safety Code, 2023 is hereby amended to read as follows:

Section D107 NEW ONE- OR TWO-FAMILY RESIDENTIAL DEVELOPMENTS, New developments of one- or two-family dwellings where the number of dwelling units exceeds 30 shall be provided with two separate and approved fire apparatus access roads.

Exceptions:

1. Where there are more than 30 dwelling units accessed from a single public or private fire apparatus access road, and all dwelling units are equipped throughout with an approved automatic sprinkler system in accordance with Section 903.3.1.1, 903.3.1.2 or 903.3.1.3, access from two directions shall not be required. This exception does not apply when the dwelling units are located in the Very High Fire Hazard Severity Zone.

VOLUME VII. SECURITY STANDARDS

SECTION VII-1. Volume VII of the Glendale Building and Safety Code, 2023

is hereby adopted to read as follows:

1. Title. This Code shall be referred to and cited as Volume VII of the Glendale Building and Safety Code, 2023.

2. Purpose. The purpose of this Code is to provide minimum standards to safeguard property and public welfare by regulating and controlling the design, construction, quality of materials, use and occupancy, location and maintenance of all buildings and structures within the City of Glendale as required in Section 14051 of the California Penal Code relating to Building Security.

3. Scope.

3.1. New Construction. The provisions of this Code shall apply to new construction and to additions or alterations to existing buildings and structures except as specifically provided by this Code.

3.2. Existing Multiple Family Dwellings. Existing multiple family dwelling units which are converted to privately owned family units (condominiums or cooperatives) shall comply with the provisions of Section 14 (Special Residential Building Provisions) in this Code.

3.3 Exemption. Any building as defined in Volume IA, IB and Title 19 - California Administrative Code, requiring special type releasing latching, or locking devices, other than described herein, shall be exempt from the provisions hereof relating to locking devices of interior and exterior doors.

4. Definitions. For the purpose of this Code certain terms are defined as follows:

APPROVED. Approved shall mean certified as meeting the requirements of this Code by the enforcing authority or its authorized agents, or by other officials designated by law to give approval on a particular matter dealt with by the provisions of this Code with regard to a given material, mode of construction, piece of equipment or device.

AUXILIARY LOCKING DEVICE. Auxiliary Locking Device shall mean a secondary locking system added to the primary locking system to provide additional security.

BOLT. Bolt shall mean a metal bar which, when actuated, is projected (or thrown) either horizontally or vertically into a retaining member, such as a strike plate, to prevent a door or window from moving or opening.

BOLT PROJECTION OR BOLT THROW. Bolt projection or bolt throw shall mean the distance from the edge of the door, at the bolt center line to the farthest point on the bolt in the projected position.

BURGLARY RESISTANT GLAZING. Burglary resistant glazing shall mean those materials as defined in Underwriter's Laboratory (U.L.) Bulletin 972.

COMMERCIAL BUILDING. Commercial building shall mean a building, or portion thereof used for a purpose other than for a dwelling.

COMPONENT. Component, as distinguished from a part, shall mean a subassembly which combines with other components to make up a total door or window assembly. For example, the primary components of a door assembly include: door, lock, hinges, jamb/wall, jamb/strike and wall.

CYLINDER. Cylinder shall mean the subassembly of a lock containing the cylinder core, tumbler mechanism and the keyway. A double cylinder lock is one which has a key-actuated cylinder on both the exterior and interior of the door.

CYLINDER CORE OR CYLINDER PLUG. Cylinder core or cylinder plug shall mean the central part of a cylinder containing the keyway, which is rotated by the key to operate the lock mechanism.

CYLINDER GUARD. Cylinder guard shall mean a tapered or flush metal ring or plate surrounding the otherwise exposed portion of a cylinder lock to resist cutting, drilling, prying, pulling, or wrenching with common tools.

DEADBOLT. Deadbolt shall mean a lock bolt which does not have a spring action as opposed to a latch bolt, which does. Deadbolts shall conform to the requirements of locks or latches prescribed in Volume IA and IB of this Code and shall comply with Grade I ANSI-designation deadbolt locks.

DEAD LATCH OR DEADLOCKING LATCH BOLT. Dead latch or deadlocking latch bolt shall mean a spring actuated latch bolt having a beveled end and incorporating a plunger which, when depressed, automatically locks the projected latch bolt against return by end pressure.

DEMISING WALL. A common wall that separates one tenant's space from another or from the building's common areas shall be constructed from the floor to the roof or floor deck above.

DOOR ASSEMBLY. Door assembly shall mean a unit composed of a group of parts or components which make up a closure for an opening to control passageway through a wall. For the purposes of this Code, a door assembly consists of the following parts:

door, hinges, locking device or devices, operation contacts (such as handles, knobs, push plates), miscellaneous hardware and closures, the frame, including the head, threshold and jambs plus the anchorage divides to the surrounding wall and a portion of the surrounding wall extending 36 inches (914mm) from each side of the jambs and 26 inches (660mm) from the head.

DOOR STOP. Door stop shall mean that projection along the top and sides of a door jamb which checks the door's swinging action.

DOUBLE CYLINDER DEADBOLT. Double cylinder deadbolt shall mean a deadbolt lock which can be activated only by a key on both the interior and exterior.

DWELLING. Dwelling shall mean a building or portion thereof designed primarily for residential occupancy, including single family and multiple family dwellings.

ENFORCING AUTHORITY. Enforcing authority shall mean the agency or person having the responsibility for enforcing the provisions of this volume.

FLUSHBOLT. Flushbolt shall mean a manual, key, or turn operated metal bolt normally used on inactive door(s) and is attached to the top and bottom of the door and engages the head and threshold of the frame.

FULLY TEMPERED GLASS. Fully tempered glass shall mean those materials meeting or exceeding ANSI standard Z 97.1 - Safety Glazing.

JAMB. Jamb shall mean the vertical members of a door frame to which the door is secured.

JAMB/WALL. Jamb/wall shall mean that component of a door assembly to which a door is attached and secured; the wall and jamb used together are considered a unit.

KEY-IN-KNOB. Key-in-knob shall mean a lockset having the key cylinder and other lock mechanisms contained in the knob.

LATCH OR LATCH BOLT. Latch or latch bolt shall mean a beveled, spring-actuated bolt which may or may not have a deadlocking device.

LOCK OR LOCKSET. Lock (or lockset) shall mean a keyed device (complete with cylinder, latch or deadbolt mechanism, and trim such as knobs, levers, thumb turns, escutcheons, or shields and guards, etc.) for securing a door in a closed position against forced entry. For the purposes of this Code, a lock does not include the strike plate.

LOCKING DEVICE. Locking device shall mean a part of a window assembly which is intended to prevent movement of the movable sash, which may be the sash lock or sash operator.

MULTIPLE FAMILY DWELLING. Multiple family dwelling shall mean a building or portion thereof designed for occupancy by two or more families living independently of each other, including hotels, motels, apartments, duplexes and townhouses.

PANIC HARDWARE. Panic hardware shall mean a latching device on a door assembly for use when emergency egress is required due to fire or other threat to life safety.

Devices shall be designed so that they will facilitate the safe egress of people in case of an emergency when a pressure not to exceed 15 lbs. (66.72N) is applied to the releasing device in the direction of exit travel. Such releasing devices are bars or panels extending not less than two-thirds of the width of the door and placed at heights suitable for the service required, not less than 30 inches (762mm) or more than 44 inches (1118mm) above the floor.

PART. Part, as distinguished from component, shall mean a unit (or subassembly) which combines with other units to make up a component.

PRIMARY LOCKING DEVICE. Primary locking device shall mean the single locking system on a door or window unit whose primary function is to prevent unauthorized intrusion.

PRIVATE OR SINGLE FAMILY DWELLING. Private or single family dwelling shall mean a building designed exclusively for occupancy by one family.

RAIL. Rail shall mean the horizontal member of a window or door. A meeting rail is one which mates with a rail of another sash or a framing member of the door or window frame when the sash is in the closed position.

SASH. Sash shall mean an assembly of stiles, rails, or mullions assembled into a single frame which supports the glazing material. A fixed sash is one which is not intended to be opened. A movable sash is intended to be open.

SILL. Sill shall mean the lowest horizontal member of a window frame.

SINGLE CYLINDER DEADBOLT. Single cylinder deadbolt shall mean a deadbolt lock which is activated from the outside by a key and from the inside by a knob, thumb-turn, lever, or similar mechanism.

SOLID CORE DOOR. Solid core door shall mean a door composed of solid wood or composed of compressed wood equal in strength to solid wood construction.

STILE. Stile shall mean a vertical framing member of a window or door.

STRIKE. Strike shall mean a metal plate attached to or mortised into a door or door jamb to receive and to hold a projected latch bolt and/or deadbolt in order to secure the door to the jamb.

SWINGING DOOR. Swinging door shall mean a door hinged at the stile or at the head and threshold.

U.L. LISTED. U.L. Listed shall mean tested and listed by Underwriter's Laboratory, Inc.

WINDOW ASSEMBLY. Window assembly shall mean a unit which includes a window and the anchorage between the window and the wall.

WINDOW FRAME. Window frame shall mean that part of a window which surrounds and supports the sashes and is attached to the surrounding wall. The members include side jambs (vertical), head jamb (upper, horizontal), sill and mullions.

5. Enforcement Provisions. The enforcing authority is directed to administer and enforce the provisions of this Code. The enforcing authority shall be the building official as defined in Volume IA of this Code.

6. Right of Entry. The enforcing authority shall have the right, and is hereby authorized and empowered, to enter or go on or about any building as provided by Chapter I Division II Section [A] 104.6 of Volume IA of this Code.

7. Violations and Penalties. It shall be unlawful for any person, firm or corporation to erect, construct, enlarge, alter, move, improve, convert, demolish, equip, use, occupy or maintain any building or structure in the City of Glendale, or cause same to be done, contrary to or in violation of any of the provisions of this Code.

8. Exemptions, Appeals. Appeals of orders, decisions or determinations made by the building official relative to the applications and interpretations of this Code shall be in accordance with Chapter I Division II Section 113 of Volume IA of this Code.

9. Alternate Materials and Methods of Construction. The provisions of this Volume are not intended to prevent the use of any material or method of construction not specifically prescribed herein, provided any such alternate has been approved by the enforcing authority or as provided in Section 5, nor is it the intention of this Volume to exclude any similarly approved sound method or structural design or analysis not specifically provided for in this Volume. Materials, methods of construction, or structural design limitations provided for in this Volume are to be used unless an exception is granted by the enforcing authority. Such alternate materials or methods may be approved provided it is found that the proposed design is satisfactory and the material and method of work is, for the purpose intended, at least equivalent to that prescribed in this Code in quality, strength, effectiveness, burglary resistance, durability and safety.

10. Keying Requirements. Upon occupancy by the owner or proprietor, each single unit in a tract or commercial development, constructed under the same general plan, shall have locks using combinations which are interchange free from locks used in all other separate dwellings, proprietorships or similar distinct occupancies. A certificate from the lock supplier declaring that all locks supplied to the project are keyed separately shall be acceptable as complying with the above requirements.

11. Frames, Jambs, Strikes, Hinges: Installation and Construction. Installation and construction of frames, jambs, strikes and hinges shall be as follows:

1. Door Jambs. Door jambs shall be installed with solid backing in such a manner that no voids exist between the strike side of the jamb and the frame opening for a vertical distance of six (6) inches (153mm) each side of the strike.

2. Framing. In wood framing, horizontal blocking shall be placed between studs at door lock height for three (3) stud spaces each side of the door openings.

Jambs shall have solid backing against sole plates.

3. Door Stops. Door stops on wooden jambs for in-swinging doors shall be of one piece construction with the jamb. Jambs for all doors shall be constructed or protected so as to prevent violation of the strike.

4. Strike Plate. The strike plate for deadbolts on all wood frame doors shall be constructed of minimum sixteen (16) U.S. gauge steel, bronze, or brass and secured to the jamb by a minimum of two screws.

5. Hinges. Hinges for out-swinging doors shall be equipped with non-removable hinge pins or a mechanical interlock to preclude removal of the door from the exterior by removing the hinge pins.

12. Windows/Sliding Glass Doors; Requirements. The following requirements must be met for windows and sliding glass doors:

1. Exterior Window; Exemptions. Except as otherwise specified in Section 14 (Special Residential Building Provisions), and Section 15 (Special Commercial Building Provisions) all operable exterior windows and sliding glass doors shall comply with the tests as set forth in Section 16 (Performance Testing).

2. Louvered Windows. Louvered windows shall not be used when any portion of the window is less than 12 feet (3658mm) vertically or 6 feet (1829mm) horizontally from an accessible surface or any adjoining roof, balcony, landing, stair tread, platform, or similar structure.

13. Garage-Type Doors. Rolling overhead, solid overhead, swing or sliding accordion garage-type doors shall conform to the following standards:

1. Wood Doors. Wood doors shall have panels a minimum of five-sixteenths (5/16) inch (8mm) in thickness with the locking hardware being attached to the support framing.

2. Aluminum Doors. Aluminum doors shall be a minimum thickness of .0215 inches (.546mm) and riveted together a minimum of eighteen (18) inches (458mm) on center along the outside seams. There shall be a full width horizontal beam attached to the main door structure which shall meet the pilot, or pedestrian access, door framing within three (3) inches (76mm) of the strike area of the pilot or pedestrian access door.

3. Fiberglass Doors. Fiberglass doors shall have panels a minimum density of six (6) ounces per square foot (1831 gram/m²) from the bottom of the door to a height of seven (7) feet (2134mm). Panels above seven (7) feet (2134mm) and panels in residential structures shall have a density not less than five (5) ounces per square foot (1526 grams/m²).

4. Cylinder Locks. Doors utilizing a cylinder lock shall have a minimum five (5) pin tumbler operation with the locking bar or bolt extending into the receiving guide a minimum of one (1) inch (25.4mm).

5. Wide Doors, Receiving Points. Doors that exceed sixteen (16) feet (4877mm) in width shall have two lock receiving points; or, if the door does not exceed nineteen (19) feet (5791mm), a single bolt may be used if placed in the center of

the door with the locking point located either at the floor or door frame header; or, torsion spring counter balance type hardware may be used.

6. Electrically Operated Doors. Except in a residential building, doors secured by electrical operation shall have a keyed-switch to open the door when in a closed position, or by a signal locking device.

7. Slide Bolt Assemblies. Doors with slide bolt assemblies shall have frames a minimum of .120 inches (3mm) in thickness, with a minimum bolt diameter of one-half (½) inch (13mm) and protrude at least one and one-half (1-1/2) inches (38mm) into the receiving guide. A bolt diameter of three-eighths (3/8) inch (10mm) may be used in a residential building. The slide bolt shall be attached to the door with non-removable bolts from the outside. Rivets shall not be used to attach slide bolt assemblies.

8. Padlock(s). Except in a residential building, padlock(s) used with exterior mounted slide bolt(s) shall have a hardened steel shackle locking both at heel and toe and a minimum five pin tumbler operation with a non-removable key when in an unlocked position. Padlock(s) used with interior mounted slide bolt(s) shall have a hardened steel shackle with a minimum four pin tumbler operation. A certificate of verification from the contractor/owner declaring that he has advised the occupant of the padlock requirements of this section shall be acceptable as complying with the above requirements.

14. Special Residential Building Provisions.

14.1. Swinging Exterior Doors. Except for vehicular access doors, all exterior swinging doors of any residential building and attached garages, including the

door leading from the garage area into the dwelling unit shall be equipped as follows:

1. Wood Doors. All wood doors shall be of solid core construction with a minimum thickness of one and three-fourths (1-3/4) inches (45mm), or with panels not less than nine-sixteenths (9/16) inch (15mm) thick.

2. Locks. A single or double door shall be equipped with a single cylinder deadbolt lock. The bolt shall have a minimum projection of one (1) inch (25.4mm) and be constructed so as to repel cutting tool attack. The deadbolt shall have an embedment of at least three-fourths (3/4) inch (19mm) into the strike receiving the projected bolt. The cylinder shall have a cylinder guard, a minimum of five pin tumblers, and shall be connected to the inner portion of the lock by connecting screws of at least one fourth (1/4) inch (6.3mm) in diameter. All installation shall be done so that the performance of the locking device will meet the intended anti-burglary requirements. A dual locking mechanism constructed so that both deadbolt and latch can be retracted by a single action of the inside door knob, or lever, may be substituted provided it meets all other specifications for locking devices.

3. Double Doors. The inactive leaf of double doors shall be equipped with metal flush bolts having a minimum embedment of five-eighths (5/8) inch (16mm) into the head and threshold or the door frame.

4. Glazing. Glazing in exterior doors or within forty (40) inches (1016mm) of any locking mechanism shall be of fully tempered glass or rated burglary resistant glazing.

5. Wide Angle Viewer. Except where clear vision panels are installed, all front exterior doors shall be equipped with a wide angle (180^o) door viewer.

14.2. Address Number and Identifying Data. Address numbers and other identifying data shall be displayed as follows:

1. Address Number. All residential dwellings shall display an address number in a prominent location on the street side of the residence in such a position that the number is easily visible to approaching emergency vehicles. The numerals shall be no less than four (4) inches (102mm) in height and shall be of a contrasting color to the background to which they are attached. In addition, any multi-family residence which affords vehicular access to the rear through any driveway, alleyway or parking lot shall also display the same numbers on the rear of the building. (See also Volume VI Section 505.1)

2. Multiple Family Dwelling; Illuminated Diagrams and Identification Numbers. There shall be positioned at each entrance of a multiple family dwelling complex an illuminated diagrammatic representation of the complex which shows the location of the viewer, the unit designations within the complex, each unit that is a “non smoking” unit (as governed by Chapter 8.52 of the Glendale Municipal Code, 1995, or any successor

legislation), the smoking permitted area authorized under Section 8.52.130 of the GMC and the complex's exits, stairwells, elevators, fire alarm annunciator panels, and standpipes. In addition, each individual unit within the complex shall display a prominent identification number, not less than four (4) inches (102mm) in height, which is easily visible to approaching vehicular and/or pedestrian traffic. In addition, any multiple family dwelling which affords vehicular access to the rear through any driveway, alleyway or parking lot shall also display the same numbers on the rear of the building.

14.3. Lighting; Multiple Family Dwellings. Lighting in multiple family dwellings shall be as follows:

1. Aisles, Passageways and Recesses. Aisles, passageways and recesses related to and within the building complex shall be illuminated with an intensity of at least twenty-five hundredths (.25) of a footcandle (2.7 lux) at the ground level during the hours of darkness. Lighting devices shall be protected by weather and vandalism-resistant covers.

2. Parking Structures, Parking Lots and Carports. Parking structures, parking lots and carports shall be provided with a minimum of two (2) foot-candles (21.5 lux) of light on the parking surface during the hours of darkness. Lighting devices shall be protected by weather and vandalism-resistant covers.

15. Special Commercial Building Provisions.

15.1. Swinging Exterior Doors; Construction and Glazing. Swinging exterior glass doors, wood or metal doors with glass panels, and solid wood or metal doors of commercial buildings shall be constructed or protected as follows:

1. Wood Doors Construction. Wood doors shall be of solid core construction with a minimum thickness of one and three-fourths (1-3/4) inches (45mm). Wood panel doors with panels less than one (1) inch (25.4mm) thick shall be covered on the inside with a minimum sixteen (16) U.S. gauge sheet steel, or its equivalent, which is to be attached with screws on minimum six (6) inch (153mm) centers. Hollow steel doors shall be a minimum of sixteen (16) U.S. gauge steel and have sufficient reinforcement to maintain the designed thickness of the door when any locking device is installed; such reinforcement being able to restrict collapsing of the door around any locking device.

2. Glazing, Iron or Steel Grills. Except when double cylinder deadbolts are utilized, any glazing within 40 inches (1016mm) of any door locking mechanism shall be constructed or protected as follows:

- 2.1. Fully tempered glass or rated burglary resistant glazing; or
- 2.2. Iron or steel grills of at least one-eighth (1/8) inch (3mm) material with a minimum two (2) inches (52mm) mesh secured on the inside of the glazing may be utilized; or
- 2.3. The glazing shall be covered with iron bars of at least one-half (1/2) inch (13mm) round or one inch by one-fourth inch (1" x 1/4") (24.5mm x 7mm) flat steel material, spaced not

more than five (5) inches (122mm) apart, secured on the inside of the glazing.

- 2.4. Items 2.2 and 2.3 above shall not interfere with the operation of opening windows if such windows are required to be openable by the Glendale Building and Safety Code, 2014.

15.2. Swinging Exterior Doors, Equipment and Construction. All swinging exterior wood and steel doors of commercial buildings shall be equipped as follows:

- 1. Deadbolts.** A single or double door shall be equipped with a double or single cylinder deadbolt. The bolt shall have a minimum projection of one (1) inch (25.4mm) and be constructed so as to repel cutting tool attack. The deadbolt shall have an embedment of at least three-fourths (3/4) inch (19mm) into the strike receiving the projected bolt. The cylinder shall have a cylinder guard, a minimum of five pin tumblers, and shall be connected to the inner portion of the lock by connecting screws of at least one-fourth (1/4) inch (7mm) in diameter. The provisions of the preceding paragraph do not apply where (1) panic hardware is required, or (2) an equivalent device is approved by the building official.

- 2. Construction and Equipment.** Double doors shall be constructed and equipped as follows:

- 2.1. The inactive leaf of double door(s) shall be equipped with metal flush bolts having a minimum embedment of five-eighths (5/8) inch (16mm) into the head and threshold of the door frame.

- 2.2. Double doors shall have an astragal constructed of steel a minimum of .125 inch (3mm) thick which will cover the opening between the doors. The astragal shall be a minimum of two (2) inches (51mm) wide, and extend a minimum of one (1) inch (25.4mm) beyond the edge of the door to which it is attached. The astragal shall be attached to the outside of the active door by means of welding or with non-removable bolts spaced apart on not more than ten (10) inch (254mm) centers.

15.3. Aluminum Door Equipment. Aluminum frame swinging doors of commercial buildings shall be equipped as follows:

1. The jamb on all aluminum frame swinging doors shall be so constructed or protected to withstand 1600 pounds (7117N) of pressure in both a vertical distance of three (3) inches (76mm) and a horizontal distance of one (1) inch (25.4mm) each side of the strike, so as to prevent violation of the strike.
2. A single or double door shall be equipped with a double cylinder deadbolt with a bolt projection exceeding one (1) inch (25.4mm), or a hook shape or expanding dog bolt that engages the strike sufficiently to prevent spreading. The deadbolt lock shall have a minimum of five pin tumblers and a cylinder guard.

15.4. Panic Hardware. Panic hardware in commercial buildings, whenever otherwise required by this Code or Title 19, California Administrative Code, shall be installed as follows:

1. Panic hardware shall contain a minimum of two (2) locking points on each door; or

2. On single doors, panic hardware may have one locking point which is not to be located at either the top or bottom rails of the door frame. The door shall have an astragal constructed of steel .125 inch (3mm) thick which shall be attached with non-removable bolts to the outside of the door. The astragal shall extend a minimum of one (1) inch (25.4mm) beyond the edge of the door to which it is attached.
3. Double doors containing panic hardware shall have an astragal attached to the doors at their meeting point which will close the opening between them, but not interfere with the operation of either door.

15.5. Sliding Doors. Horizontal sliding doors in commercial buildings shall be equipped with a metal guide track at top and bottom and a cylinder lock and/or padlock with a hardened steel shackle which locks at both heel and toe, and a minimum five pin tumbler operation with non-removable key when in an unlocked position. The bottom track shall be so designed that the door cannot be lifted from the track when the door is in a locked position.

15.6. Office Buildings; Doors to Suites. In office buildings with multiple occupancy, all entrance doors to individual office suites shall meet the construction and locking requirements for exterior doors.

15.7. Accessible Windows. Windows in commercial buildings shall be deemed accessible if less than twelve (12) feet (3658mm) above the ground. Accessible windows having a pane exceeding ninety-six (96) square inches (61935mm²) in an area with the smallest dimension exceeding six (6) inches (153mm) and not visible from a public

thoroughfare (including any street, alleyway or sidewalk supported and maintained through public funds) shall be protected in the following manner.

1. Fully tempered glass or burglary resistant glazing; or
2. The following window barriers may be used but shall be secured with non-removable bolts:
 - 2.1. Inside or outside iron bars of at least one-half ($\frac{1}{2}$) inch (13mm) round or one by one-quarter (1 x $\frac{1}{4}$) inch (25.4mm x 7mm) flat steel material, spaced not more than five (5) inches (127mm) apart and securely fastened; or
 - 2.2. Inside or outside iron or steel grills of at least one-eighth ($\frac{1}{8}$) inch (3mm) material with not more than a two (2) inch (51mm) mesh and securely fastened.
3. If a side or rear window is of the type that can be opened, it shall, where applicable, be secured on the inside with either a slide bar, bolt, crossbar, auxiliary locking device, and/or padlock with hardened steel shackle and a minimum four pin tumbler operation.
4. The protective bars or grills shall not interfere with the operation of opening windows if such windows are required to be openable by this Code.

15.8. Exterior Transoms. All exterior transoms exceeding ninety-six (96) square inches (61935mm²) on the side and rear of any commercial building or premises used for business purposes shall be protected by one of the following:

1. Fully tempered glass or rated burglary resistant glazing; or

2. The following barriers may be used but shall be secured with non-removable bolts:
 - 2.1. Outside iron bars of at least one-half ($\frac{1}{2}$) inch (13mm) round or one by one-quarter ($1 \times \frac{1}{4}$) inch (25.4mm x 7mm) flat steel material, spaced no more than five (5) inches (127mm) apart and securely fastened; or
 - 2.2. Outside iron or steel grills of at least one-eighth ($\frac{1}{8}$) inch (3mm) with not more than a two (2) inches (51mm) mesh and securely fastened.
3. The protective bars or grills shall not interfere with the operation of opening the transoms if such transoms are required to be openable by this Code or Title 19, California Administrative Code.

15.9. Roof Openings. Roof openings of commercial buildings shall be equipped as follows:

1. All skylights on the roof of any building or premise used for business purposes shall be provided with:
 - 1.1. Rated burglary resistant glazing; or
 - 1.2. Iron bars of at least one-half ($\frac{1}{2}$) inch (13mm) round or one by one-fourth ($1 \times \frac{1}{4}$) inch (25.4mm x 7mm) flat steel material under the skylight and securely fastened; or
 - 1.3. A steel grill of at least one-eighth ($\frac{1}{8}$) inch (3mm) material with a maximum two (2) inches (51mm) mesh under the skylight and securely fastened.
2. All hatchway openings on the roof of any building or premises used for business purposes shall be secured as follows:

- 2.1. If the hatchway is of wooden material, it shall be covered on the inside with at least sixteen (16) U.S. gauge sheet metal, or its equivalent, attached with screws.
 - 2.2. The hatchway shall be secured from the inside with a slide bar or slide bolts.
 - 2.3. Outside hinges on all hatchway openings shall be provided with non-removable pins when using pin-type hinges.
3. All air duct or air vent openings exceeding ninety-six (96) square inches (61935mm²) on the roof or exterior walls of any building or premises used for business purposes shall be secured by covering the same with either of the following:
- 3.1. Iron bars of at least one-half (½) inch (13mm) round or one by one-fourth (1 x 1/4) inch (25.4mm x 7mm) flat steel material spaced no more than five (5) inches (127mm) apart and securely fastened; or
 - 3.2. Iron or steel grills of at least one-eighth (1/8) inch (3mm) material with a maximum two (2) inches (51mm) mesh and securely fastened.
 - 3.3. If the barrier is on the outside, it shall be secured with bolts which are non-removable from the exterior.
 - 3.4. The above (3.1 and 3.2) must not interfere with venting requirements creating a potentially hazardous condition to health and safety or conflict with the provisions of this Code or Title 19, California Administrative Code.

Exceptions:

1. Air duct openings covered by mechanical equipment weighing more than 200 lbs. (890N) or sufficiently anchored with duct access(es) sufficiently secured.
2. A security system approved by the building official.

15.10. Permanent Ladders. Permanently affixed ladders leading to roofs of commercial buildings shall be fully enclosed with sheet metal to a height of ten feet (3048mm). This covering shall be locked against the ladder with a case hardened hasp, secured with non-removable screws or bolts. Hinges on the cover will be provided with non-removable pins when using pin-type hinges. If a padlock is used, it shall have a hardened steel shackle, locking at both heel and toe, and a minimum five pin tumbler operation with non-removable key when in an unlocked position.

15.11. Address Numbers, Identifying Data, and Illumination. The following standards shall apply to lighting, address identification and parking areas:

1. The address number of every commercial building shall be illuminated during the hours of darkness so that it shall be easily visible from the street. The numerals in these numbers shall be no less than six (6) inches (153mm) in height and be of a color contrasting to the background. In addition, any business which affords vehicular access to the rear through any driveway, alleyway or parking lot shall also display the same numbers on the rear of the building.
2. All exterior commercial doors, during the hours of darkness, shall be illuminated with a minimum of one (1) footcandle (10.796 lux) of light. All exterior bulbs shall be protected by weather and vandalism-resistant covers.

3. Parking structures, open parking lots and access thereto, providing more than ten parking spaces and for use by the general public, shall be provided with a maintained minimum of one (1) footcandle (10.769 lux) of light on the parking surface from dusk until the termination of business every operating day.

16. Performance Testing.

16.1. Responsibility of Owner. It shall be the responsibility of the owner or his or designated agent, of a building or structure falling within the provisions of this Volume, to provide the enforcing authority with a written specification performance test report indicating that the materials utilized meet the minimum requirements.

16.2. Proof of Compliance. Whenever there is sufficient evidence of compliance with the provisions of this Volume or evidence that any material or any construction does not conform to the requirements of this Volume, or in order to substantiate claims for alternate materials or methods of construction, the enforcing authority may require tests as proof of compliance to be made at the expense of the owner or his agent by any agency which is approved by the enforcing authority.

16.3. Verification. Specimens shall be representative, and the construction shall be verified by assembly drawings and bill of materials. Two complete sets of manufacturer or fabricator installation instructions and full-size or accurate scale templates for all items and hardware shall be included.

16.4. Testing Methods. The enforcing authority shall establish and adopt testing methods which shall substantially meet the minimum standards in the most recent edition of the California Building Code.

VOLUME VIII.

**COMMERCIAL AND INDUSTRIAL PROPERTY
MAINTENANCE CODE**

SECTION VIII-1. Volume VIII of the Glendale Building and Safety Code, 2023, is hereby adopted to read as follows:

10. PURPOSE. The Council of the City of Glendale has determined that the economic vitality of the City is directly impacted by the visual character and physical condition of its commercial and industrial neighborhoods. It is the purpose of this code to provide minimum standards for maintenance of properties in these districts, improve community appearance, and to protect the public health, safety and welfare of individuals who live, work, shop and/or operate business within and surrounding these districts.

The goals of this code are to promote an attractive business community that will help serve the economic and social interests of the City, to enhance the value of all commercial and industrial property and promote the overall economic development within the City by preventing commercial and industrial properties from becoming blighted resulting in diminution in the enjoyment, use, and property values of properties in and around the commercial and industrial areas. In adopting this code, it is the Council's intention to set forth maintenance standards for commercial and industrial properties.

20. SCOPE. The standards set forth in this code shall apply to all lots and parcels in all commercial and industrial zoning districts, as defined in Title 30 of the Glendale Municipal Code, 1995 ("GMC") and all structures located on such real property.

30. DEFINITIONS. For the purpose of this code, the following words and phrases shall have the following meanings:

"**COMMERCIAL LANDSCAPING AREAS**" shall be as defined by Title 30 of the GMC or as a "condition of approval" of a discretionary action in any commercial, commercial/industrial or industrial zone.

"**VISUALLY OPAQUE**" shall mean material that does not allow the viewing of images through it.

40. AUTHORIZATION. The building official or his or her designee(s) is authorized and directed to enforce the provisions of this code. For such purposes the building official shall have the powers of a law enforcement officer. The building official shall have the power to render interpretations of this code and to adopt and enforce rules and supplemental regulations in order to clarify the application of its provisions.

50. MAINTENANCE OF PROPERTY, GENERALLY. All property, buildings and structures or portions thereof shall be maintained in clean, and neat condition, in good repair and free of graffiti:

It is unlawful and deemed a public nuisance for any person owning, leasing, occupying or managing any commercial, commercial/industrial or industrial zoned property to maintain property contrary to this code.

60. SUBSTANDARD PROPERTY. Any building, structure or portion thereof which is determined to be an unsafe building in accordance with Chapter 1 Division II Section 116, Volume IA, Glendale Building and Safety Code, 2020; or any building or portion thereof, or the premises on which the same is located, in which there exists any of the following listed conditions shall be deemed and hereby is declared to be a substandard building and a violation of this code:

1. Any building, structure or portion thereof that is dilapidated, dangerous, abandoned, partially destroyed, or unsafe as defined in the Glendale Building and Safety Code, 2023, resulting from decay, damage, faulty construction or arrangement, fire, wind, earthquake, flood old age or neglect, inadequate exits, human or mechanical damage, or improper occupancy;
2. Any building, structure or portions thereof on which the condition of the paint has become so deteriorated as to permit decay, excessive checking, cracking, peeling, chalking, dry rot, warping, or termite infestation;
3. Any building, structure, wall or fence on which graffiti has been placed which is visible from a public street;
4. Any premises, building or portions thereof that are unsanitary. Unsanitary conditions shall include, but not be limited to, infestation of insects, vermin or rodents, rubbish, trash or debris maintained in any doorway or vestibule, lack of adequate garbage and rubbish storage and removal facilities, and/or lack of or improper connection to required sewage disposal system;
5. All electrical service to any electrical wiring devices, appliance, or equipment which is found to be dangerous to life or property because they are defective or improperly installed or used;
6. Plumbing which was installed in violation of GMC requirements in effect at the time of installation or which has not been maintained in a sanitary and safe operating condition;
- 7.a. All mechanical systems, materials and appurtenances, both existing and new equipment which were installed in violation of the code edition under which

installed and/or not maintained in proper operating condition in accordance with the original design and in a safe and hazard free condition.

- b. Screening devices used to obstruct the view of such devices which are not maintained in a clean and neat condition;
 - c. Any equipment and/or screening device or part thereof that is defective, broken, damaged, or weathered;
8. Any building or portions thereof which has faulty weather protection which shall include, but not be limited to, deteriorated or ineffective waterproofing of exterior walls, roofs, foundations or floors, parapets, including broken windows or doors, defective or lack of weather protection for exterior wall coverings, including lack of paint, or weathering due to lack of paint or other protective covering, or broken, rotted, split, or buckled exterior wall coverings or roof coverings and damaged or non-functioning drainage structures;
 9. Any building, premises or portions thereof, device, apparatus, equipment, combustible waste or vegetation which is in such a condition as to cause a fire or explosion or provide a ready fuel to augment the spread and intensity of fire or explosion arising from any cause; or
 10. Except as provided in Title 30 of the GMC, the accumulation of weeds, vegetation, junk, abandoned or inoperable motor vehicles, dead organic matter, debris, garbage, offal, rat harborages, stagnant water, combustible materials or similar materials on a premises or property;
 11. Inadequate or inoperative night and security lighting on a premises or property.

70. DECLARATION OF SUBSTANDARD PROPERTY. Whenever the building official or his or her designee(s) finds that a substandard condition(s) exist on any property covered by this code, he or she shall declare the building, structure, and/or premises as substandard and require the owner to complete repairs, removal or clearing of such condition(s) within the time set forth in a notification to the property owner of the substandard conditions. All notices and orders to the property owner shall be issued and recorded pursuant to Chapter 11, Volume V, Glendale Building and Safety Code, 2023.

80. VACANT OR UNOCCUPIED BUILDINGS OR STRUCTURES. Vacant or unoccupied buildings or structures, and the property on which they are constructed, shall be continuously maintained to the standards set forth in this code.

90. PREMISES, GENERALLY. Premises of commercial, commercial/industrial and industrial zoned properties shall be maintained free of dirt, litter and debris.

Entryways, porticos, alcoves and vestibules shall be maintained free of dirt, litter and debris.

Windows and window displays shall be clean. Temporary window signs and display materials as permitted by Title 30 of the GMC which have become faded, torn or in disrepair are prohibited.

Awnings must be in good repair. Awnings which are faded or torn or on which lettering is becoming detached, faded or in poor repair are prohibited.

A violation of Section 90 shall be deemed an infraction punishable as provided in Section 1.20 and 1.24 of the GMC.

100. CONSTRUCTION SITES. Work must proceed in a timely manner pursuant to Chapter I Division II Section 105.5, Volume IA of the Glendale Building and Safety Code, 2023.

The accumulation of dirt, litter, debris, and equipment in or on the adjoining street, and/or sidewalk during construction shall be prohibited, unless otherwise permitted pursuant to a City of Glendale permit.

110. SIGNS. All signs and sign structures erected or placed on properties within the Commercial and Manufacturing Zones shall be maintained in a good and safe structural condition, shall be painted on all exterior parts at least as often as required to prevent fading, chipping, peeling and rusting, and shall be maintained in good condition and appearance as specified in Section 30.33 of the GMC.

A violation of Section 110 shall be deemed an infraction punishable as provided in Section 1.20 and 1.24 of the GMC.

120. LANDSCAPING AND IRRIGATION. All planting material and planting beds shall be permanently maintained in a clean, orderly and healthy manner at all times, pursuant to requirements set forth in Title 30 of the GMC. Any landscaping that is not in a healthy or living state shall be replaced. If a landscape plan is part of any City approval, the replacement of such planting material shall be in accordance with the approved landscaping plan. Proposals to modify an approved landscaping plan, which has been in effect for more than two years, may be reviewed and approved by the Director of Community Development, without the necessity of returning to the Design Review Board or other permitting authority. For those commercial or industrial properties within a redevelopment project area, any of the modifications under the

conditions set forth above, may be reviewed and approved by the Director of Community Development.

No landscaping shall be permitted in areas where such landscaping in any way endangers the health, or public safety by creating a traffic hazard, by obstructing vision, or which is detrimental or harmful to the use of surrounding properties.

All irrigation systems shall be maintained in good repair and working condition. Said systems shall be adjusted so as not to spray across or into any sidewalk, driveway, and/or street.

Violation of Section 120 shall be deemed an infraction punishable as provided in section 1.20 and 1.24 of the GMC.

130. PARKWAYS AND PUBLIC RIGHTS-OF-WAY. All sidewalks and parkways located adjacent to and adjoining commercial or industrial properties shall be maintained free of junk, trash, debris, litter, painted or inked survey marks (after the work is completed or work in connection therewith), appliances, furniture, overgrown and unpruned privately owned trees and shrubs, weeds and grass in excess of six (6) inches in height, by the owner or the responsible party in control of such property. Landscaping in parkways shall be permanently maintained in a clean, orderly and healthy manner at all times, pursuant to requirements set forth in Chapter 8.32 of the GMC.

140. PARKING SPACES, LOTS AND STRUCTURES. All parking lots and structures and their surfaces shall be maintained in a clean, and neat condition and in good repair free of junk, trash, debris, litter, weeds, appliances, furniture, and abandoned or inoperable motor vehicles. All drainage structures shall be maintained and operable and free of standing water. All parking stalls shall be clearly identified with paint or

other approved striping materials on the surface of the parking area. All parking lot improvements, including the striping of stalls, appropriate signing and lighting, shall be permanently maintained pursuant to Chapter 30.32 of the GMC.

The following conditions or activities are prohibited:

1. The repair or servicing of any type of vehicles in any parking lot or structure, except as expressly permitted by the GMC;
2. The use of required parking spaces during regular business hours, for storage of commercial or other vehicles, including but not limited to, busses, trailers, recreational vehicles, boats and motor homes, except as otherwise expressly permitted by the GMC, or as incident to the use permitted on the site;
3. Vehicles of any type, parked or stored for sale on any parking lot or vacant parcel except in conjunction with a bona fide vehicle sales agency.

A violation of section 140 shall be deemed an infraction punishable as provided in Section 1.20 and 1.24 of the GMC.

150. LOADING AREAS. All loading areas must be maintained free and clear of junk, trash, debris, appliances, furniture or any other items. Loading areas shall be maintained in a clean and neat condition, free of any refuse that might attract or harbor rodents, vermin and/or insects.

160. OUTSIDE STORAGE AREAS. Except as provided in Title 30 of the GMC, there shall be no outside storage of tools, equipment, supplies, materials or merchandise at any time in any commercial or commercial/industrial zoning district. Temporary sheds, tents, awnings and the like are prohibited.

170. REFUSE CONTAINERS AND STORAGE AREAS. Refuse storage containers and enclosures shall be maintained in the following manner:

1. All refuse and refuse containers shall be stored within an approved storage area or within an enclosed building;
2. All refuse storage areas shall be maintained in a clean and neat manner and refuse shall not project above the height of said enclosure; and
3. All refuse storage areas shall be readily accessible to the users they serve as well as for collection operations.
4. All refuse containers shall be maintained so as to be free of graffiti. All refuse containers shall be securely covered, maintained in good repair, with no jagged or torn metal, and sealed so as not to leak liquid waste.

180. UNIMPROVED PROPERTY. Unimproved real property in any commercial, commercial/industrial or industrial zoning district shall be maintained in such a manner so as to not be a detriment to other nearby properties and not adversely affect the public's health, safety and welfare. Unimproved property shall be maintained in a clean and neat manner free of junk, trash, debris, litter, abandoned or inoperable vehicles, stagnant water, abandoned excavations, appliances and furniture, vegetation that is not in a healthy or living state and overgrown vegetation. Living vegetation shall be maintained so as not to exceed an overall height of six (6) inches except for trees and shrubs that are exempt from this requirement. Vehicles of any type shall not be parked or stored for sale on any parking lot or vacant or unimproved parcel except in conjunction with a bona fide vehicle sales agency.

190. ALTERNATIVE ACTIONS AVAILABLE. Nothing in this code shall be deemed to prevent the City from beginning a civil, criminal and/or administrative proceeding to abate the public nuisance or from pursuing the above remedies individually or collectively or pursuing any other means available to the City under the provisions of applicable ordinances or State law or as alternatives to or in conjunction with the proceedings herein set forth.

200. VIOLATIONS. Unless otherwise stated, the owner or other entity having charge or control of any structure or real property located in a commercial or industrial zoning district who maintains such structure or real property in violation of the provisions of this article is guilty of a misdemeanor.

VOLUME IX. GREEN BUILDING STANDARDS

SECTION IX-1. Volume IX of the Glendale Building and Safety Code, 2023, is amended as hereinafter provided.

SECTION IX-2. Section 301.1 of Volume IX of the Glendale Building and Safety Code, 2023, is hereby amended to read as follows:

301.1 Scope. Buildings and structures shall be designed to include the green building measures specified as mandatory in this code. Voluntary green building measures are also included in this code and may be included in the design and construction of structures covered by this code, but are not required unless adopted by a city, county, or city and county as specified in Section 101.7.

SECTION IX-3. Section 4.106.5 of Volume IX of the Glendale Building and Safety Code, 2023, is hereby added to read as follows:

4.106.5 Water permeable surfaces. Permeable paving is utilized for the parking, walking or patio surfaces in compliance with the following.

Not less than 20 percent of the total on-grade, residential uncovered parking, walking or patio surfaces shall be permeable.

Exceptions:

1. The primary driveway, primary entry walkway and entry porch or landing shall not be included when calculating the area required to be a permeable surface.

2. Required accessible routes for persons with disabilities as required by *California Code of Regulations*, Title 24, Part 2, Chapter 11A and/or Chapter 11B as applicable.

SECTION IX-4 Section 4.509 Volume IX of the Glendale Building and Safety Code, 2023, is hereby added to read as follows:

SECTION 4.509

NATURAL LIGHT AND VENTILATION

4.509.1 Natural light. The minimum net glazed area shall not be less than 10 percent of the floor area of the room served.

4.509.2 Natural ventilation. The minimum openable area to the outdoors shall be 5 percent of the floor area being ventilated.

Passed by four-fifths (4/5^{ths}) vote of the Council of the City of Glendale on the 21st day of May, 2024.



Mayor

ATTEST:



City Clerk

APPROVED AS TO FORM



CITY ATTORNEY

DATE 5/24/24

STATE OF CALIFORNIA)
COUNTY OF LOS ANGELES) SS.
CITY OF GLENDALE)

I, SUZIE ABAJIAN, Ph.D., City Clerk of the City of Glendale, certify that the foregoing Ordinance No. 6028 was passed by a four-fifths (4/5^{ths}) vote of the Council of the City of Glendale, California, at a regular meeting held on the 21st day of May, 2024, and that the same was passed by the following vote:

Ayes: Brotman, Gharpetian, Kassakhian, Najarian, Asatryan

Noes: None

Abstain: None

Absent: None



City Clerk

RESOLUTION NO. 24-80

A RESOLUTION OF THE COUNCIL OF THE CITY OF GLENDALE, ADOPTING LEGISLATIVE FINDINGS SUPPORTING AMENDMENTS AND CHANGES TO THE CALIFORNIA STATE BUILDING STANDARDS CODE AS CONTAINED IN THE GLENDALE BUILDING AND SAFETY CODE, 2023

WHEREAS, on or about November 15, 2022, the City Council of the City of Glendale adopted Ordinance No. 5998, which adopted the California Building Standards Code, which consists of the 2022 editions of the California Building Code, Residential Code, California Existing Building Code, Plumbing Code, Mechanical Code, Electrical Code, Fire Code, Green Building Standards Code, 1997 Uniform Housing Code, and made modifications and changes thereto, all of which comprise a portion of the Glendale Building and Safety Code, 2023; and

WHEREAS, on or about March of 2024, the California Building Standards Commission (CBSC) found that Ordinance No. 5998 was accepted for filing, with the exception of four specific local amendments, requiring an amendment to Ordinance No. 5998 and the previously adopted resolution adopting the legislative findings supporting amendments and changes; and

WHEREAS, the California Health and Safety Code Sections 17958, 17958.5 and 17958.7 require the governing body of a city, before making any modifications or changes to the California Building Standards Code, to make express findings that such modifications or changes are reasonably necessary because of local climatic, geological or topographical conditions; and

WHEREAS, the City Council of the City of Glendale finds that a departure from the California Building Standards Code is reasonably necessary due to local climatic, geological, or topographical conditions.

NOW THEREFORE the City Council of the City of Glendale, California, does hereby resolve as follows:

SECTION 1. Legislative Findings. Modifications and changes contained in the Glendale Building and Safety Code, 2023, are required in order to provide specific and greater protections to the public health, safety and welfare than are afforded by the California Building Standards Code due to local climatic, geological, and topographical conditions. The legislative findings for such modifications and changes are made pursuant to Sections 17958.5 and 17958.7 of the California Health and Safety Code, as set forth in the report of the Director of Community Development dated April 30, 2024, November 1, 2022 and November 15, 2022, and attachments thereto, entitled "Glendale Building and Safety Code, 2023 (Analysis of amendments to the California Code of Regulation)", attached hereto as Exhibit "1" and by this reference incorporated herein.

SECTION 2. This Resolution shall become effective on the same date as Ordinance No. 6026, which adopts and amends the California Building Standards Code, as the Glendale Building and Safety Code, 2023.

SECTION 3. The City Clerk is hereby authorized and directed to transmit a certified copy of this Resolution to the California Building Standards Commission of the State of California.

Adopted this 14th day of May, 2024.



Mayor

ATTEST:



City Clerk

APPROVED AS TO FORM



CITY ATTORNEY

STATE OF CALIFORNIA)
COUNTY OF LOS ANGELES) ss.
CITY OF GLENDALE)

DATE 5/24/24

I, SUZIE ABAJIAN, Ph.D., Clerk of the City of Glendale, certify that the foregoing Resolution was adopted by the Council of the City of Glendale, California, at a regular meeting held on the 14th day of May, 2024, and that same was adopted by the following vote:

- Ayes: Brotman, Gharpetian, Kassakhian, Najarian, Asatryan
- Noes: None
- Absent: None
- Abstain: None



City Clerk

GLENDALE BUILDING AND SAFETY CODE, 2023
(Analysis of amendments to the California Code of Regulation)

Introduction

The Glendale Building and Safety Code is comprised of ten (10) distinct volumes as follows:

- Volume IA: Building Standards (For Commercial and Multi-Family Residential)
- Volume IB: Residential Standards (For One-and-Two Family Dwellings and Townhouses)
- Volume IC: Existing Building Standards
- Volume II: Plumbing Standards
- Volume III: Mechanical Standards
- Volume IV: Electrical Standards
- Volume V: Housing Standards
- Volume VI: Fire Standards
- Volume VII: Security Standards
- Volume VIII: Commercial and Industrial Property Maintenance Standards
- Volume IX: Green Building Standards

The regulatory requirements contained within the first six (6) volumes and Volume IX contained within the California Code of Regulations (CCR), specifically, portions of Titles 19, 24, and 25. The California Building Standards Commission (CBSC) adopted such requirements into the California Building Code, California Residential Code, California Existing Building Code, California Plumbing Code, California Mechanical Code, California Electrical Code, California Fire Code, and California Green Building Standards Code. Adoption and enforcement of the Uniform Housing Code is mandated through the State Housing Law (Health and Safety Code, Division 13, Part 1.5, Section 17960). The 1997 Edition of the Uniform Housing Code was adopted by the California Department of Housing and Community Development as provided for in CCR, Title 25, Division 1, Chapter 1, Subchapter 1, Article 5, Section 32.

Local adoption of such codes is mandated on January 1, 2023. Prior to such adoption, jurisdictional bodies may amend said codes if such amendments are justified on the basis of a local climatic, local geologic or local topographic condition which makes such amendment(s) necessary.

The following summary compares the proposed amendments for the 2023 Glendale Building and Safety Code with the 2020 Glendale Building and Safety Code, and discusses the reason and justification for each such amendment. Each amendment is identified by the section number used in the proposed ordinance. Many of the proposed amendments have been renumbered to match the revised format of the International Codes upon which several of the California codes are based.

Volume IA
Building Standards

Section IA - 2.

Chapter 1 Division II, Section 101.2 Scope.

This amendment is similar to the 2008, 2011, 2014, 2017 and 2020 Glendale Building and Safety Code. This amendment refers to administrative procedures to be followed, as the State adopted the International Residential Code.

(Justification: Administrative - See justification A in the attached matrix)

Section 1A – 3.

Chapter 1 Division II, Section 104.10.2 Fire code official concurrence.

This amendment is the same as in the 1999, 2002, 2008, 2011, 2014, 2017 and 2020 Glendale Building and Safety Code.

This amendment provides administrative clarification regarding the need for concurrence by the Fire code official on appeals/slight code modifications which involve fire/life safety issues.

(Justification: Administrative - See justification A in the attached matrix)

Section IA – 4.

Chapter 1 Division II, Section 104.11.5 Fire code official concurrence.

This amendment is the same as in the 1999, 2002, 2008, 2011, 2014, 2017 and 2020 Glendale Building and Safety Code.

This amendment provides administrative clarification regarding the need for concurrence by the Fire code official on the use of alternate materials or methods of construction which involve fire/life safety issues.

(Justification: Administrative - See justification A in the attached matrix)

Section IA – 5.

Chapter 1 Division II, Section 105.1 Required.

This amendment is the same as in the 2002, 2008, 2011, 2014, 2017 and 2020 Glendale Building and Safety Code.

This amendment maintains a requirement for a permit to stripe parking lots. (Justification: Administrative - see justification A in the attached matrix)

Section IA – 6.

Chapter 1 Division II, Section 105.3 Application for permit.

This amendment is the same as the 2008, 2011, 2014, 2017 and 2020 Glendale Building and Safety Code.

This amendment establishes the requirement for a plan review fee to be paid.

(Justification: Administrative - See justification A in the attached matrix)

Section IA – 7.

Chapter 1 Division II, Section 105.3.1.1 Electric vehicle charging station review process.

This amendment is the same as in the 2017 and 2020 Glendale Building and Safety Code.

This amendment establishes administrative procedures and an expedited, streamlined permitting process for electric vehicle charging stations to facilitate convenient charging of electric vehicles and help reduce the City's reliance on environmentally damaging fossil fuels.

(Justification: Administrative, Geologic, Climatic, Topographic - See justification A, B, C, and D in the attached matrix.)

Section IA – 8.

Chapter 1 Division II, Section 105.3.2 Time limitation of application.

This amendment is the same as in the 2011, 2014, 2017 and 2020 Glendale Building and Safety Code. This amendment establishes a time limit for plan review to match legislation passed by City Council in 2005.

(Justification: Administrative - See justification A in the attached matrix)

Section IA – 9.

Chapter 1 Division II, Section 105.3.3 Plan review fees.

This amendment is the same as in the 2008, 2011, 2014, 2017 and 2020 Glendale Building and Safety Code.

This amendment provides for the establishment of fees by resolution of the City Council.

(Justification: Administrative - See justification A in the attached matrix)

Section IA – 10.

Chapter 1 Division II, Section 105.5 Expiration.

This amendment is the same as in the 2008, 2011, 2014, 2017 and 2020 Glendale Building and Safety Code.

This amendment provides a time limit for plan review to match legislation passed by city Council in 2005 and establishes the procedures for renewing action on an expired application.

(Justification: Administrative - See justification A in the attached matrix)

Section IA- 11.

Chapter 1 Division II, Section 105.8 Responsibility of permittee.

This amendment is the same as in the 1999, 2002, 2008, 2011, 2014, 2017 and 2020 Glendale Building and Safety Code. This amendment clearly establishes the permit applicant's responsibilities in express fashion, rather than reliance upon implicit understanding of same.

(Justification: Administrative - See justification A in the attached matrix)

Section IA- 12.

Chapter 1 Division II, Section 107.3.4 Design professional in responsible charge.

This amendment is the same to the 2014, 2017 and 2020 Glendale Building and Safety Code.

This amendment clearly establishes that all construction documents submitted for review shall be prepared by a registered design professional. This amendment also allows the building officials to make a determination to waive the requirement after reviewing the submitted documents and establishes the work is minor in nature.

(Justification: Administrative, Geologic, Climatic - See justification A, B and C in the attached matrix.)

Section IA – 13.

Chapter 1 Division II, Section 109.4 Work commencing before permit issuance.

This amendment is the same as in the 2011, 2014, 2017 and 2020 Glendale Building and Safety Code.

This amendment establishes the fees to be collected when a permit is issued for which the work has commenced before obtaining the permit.

(Justification: Administrative - See justification A in the attached matrix)

Section IA – 14.

Chapter 1 Division II, Section 110.3.5 Lath, gypsum board and gypsum panel product inspection.

This amendment is the same as in the 2008, 2011, 2014, 2017 and 2020 Glendale Building and Safety Code.

This amendment refers to administrative procedures to be followed when inspecting lath and gypsum board.

(Justification: Administrative - See justification A in the attached matrix)

Section IA – 15.

Chapter 1 Division II, Section 110.3.9.1 Structural observation.

This amendment is the same as in the 2008, 2011, 2104, 2017 and 2020 Glendale Building and Safety Code.

This amendment refers to administrative procedures to be followed when structural observation is required.

(Justification: Administrative - see justification A in the attached matrix)

Section IA – 16.

Chapter 1 Division II, Section R110.7 Re-inspections.

This amendment is the same as in the 2017 and 2020 Glendale Building and Safety Code.

This amendment restores and re-introduces a previous requirement in the building code that allows the Building Official to assess re-inspection fees in cases such as when inspection is called and work is not complete or when corrections called for are not made. This amendment makes the Building Standards in Volume IA of the 2020 Glendale Building and Safety Code consistent with the Residential Standards in Volume IB, Plumbing Standards in Volume II, Mechanical Standards in Volume III, and Electrical Standards in Volume IV of the 2020 Glendale Building and Safety Code.

Justification: Administrative - See justification A in the attached matrix)

Section IA – 17.

Chapter 1 Division II, Section 113 BUILDING AND FIRE BOARD OF APPEALS.

This amendment is the same as in the 2008, 2011, 2014, 2017 and 2020 Glendale Building and Safety Code.

This amendment establishes the joint Building and Fire Board of Appeals and the administrative procedures for the board.

(Justification: Administrative - See justification A in the attached matrix)

Section IA – 18.

Chapter 1 Division II, Section 114.1 Unlawful acts.

This amendment is the same as in the 2011, 2014, 2017 and 2020 Glendale Building and Safety Code.

This amendment re-introduces administrative procedures when working with unsafe buildings and structures.

(Justification: Administrative - See justification A in the attached matrix)

Section IA – 19.

Chapter 1 Division II, Section 114.4 Violation penalties.

This amendment is the same as in the 2011, 2014, 2017 and 2020 Glendale Building and Safety Code.

This amendment re-introduces administrative procedures when working with unsafe buildings and structures. This amendment is necessary to clarify administrative enforcement procedures and establishes penalties.

(Justification: Administrative - See justification A in the attached matrix)

Section IA – 20.

Chapter 1 Division II, Section 115.1 Authority.

This amendment is the same as in the 1999, 2002, 2008, 2011, 2014, 2017 and 2020 Glendale Building and Safety Code.

This amendment refers to administrative procedures to allow the building official to enforce local regulations.

(Justification: Administrative - See justification A in the attached matrix)

Section IA – 21.

Chapter 1 Division II, Section 115.3 Unlawful continuance.

This amendment is the same as in the 1999, 2002, 2008, 2011, 2014, 2017 and 2020 Glendale Building and Safety Code

This amendment identifies violations as misdemeanors.

(Justification: Administrative - see justification A in the attached matrix)

Section IA – 22.

Chapter 1 Division II, Section 116.6 Non-compliance.

This amendment is the same as in the 1999, 2002, 2008, 2011, 2014, 2017 and 2020 Glendale Building and Safety Code.

This amendment refers to administrative procedures to be followed when working with unsafe buildings or structures.

(Justification: Administrative - See justification A in the attached matrix)

Section IA – 23.

Chapter 1 Division II, Section 116.7 Vacated Buildings.

This amendment is the same as in the 1999, 2002, 2008, 2011, 2014, 2017 and 2020 Glendale Building and Safety Code.

This amendment refers to administrative procedures to be followed when working with unsafe buildings or structures.

(Justification: Administrative - See justification A in the attached matrix)

Section IA – 24.

Chapter 1 Division II, Section 118 CONSTRUCTION TOILET FACILITIES.

This amendment is the same as in the 1999, 2002, 2008, 2011, 2014, 2017 and 2020 Glendale Building and Safety Code.

This amendment requires construction sites to be equipped with available toilet facilities.

(Justification: Administrative - See justification A in the attached matrix)

Section IA – 25.

Chapter 1 Division II, Section 119 ON SITE CONSTRUCTION TRASH AND DEBRIS CONTROL.

This amendment is the same as in the 1999, 2002, 2008, 2011, 2014, 2017 and 2020 Glendale Building and Safety Code.

This amendment requires trash and debris control for facilities for construction sites,

(Justification: Administrative - See justification A in the attached matrix)

Section IA – 26.

Chapter 1 Division II, Section 120 DISASTER REPAIR AND RECONSTRUCTION.

This amendment is the same as in the 1999, 2002, 2008, 2011, 2014, 2017 and 2020 Glendale Building and Safety Code.

This amendment establishes administrative procedures related to the repair and reconstruction of structures affected by a disaster.

(Justification: Administrative - See justification A in the attached matrix)

Section IA – 27.

Chapter 1 Division II, Section 121 SANDBLASTING.

This amendment is the same as in the 1999, 2002, 2008, 2011, 2014, 2017 and 2020 Glendale Building and Safety Code.

This amendment establishes administrative regulations regarding sandblasting activities to protect adjoining property from potential damage due to over spray.

(Justification: Administrative - See justification A in the attached matrix)

Section IA – 28.

Chapter 1 Division II, Section 202 DEFINITIONS.

This amendment is new to address a new word, Intermodal Shipping Container, added to the 2020 Glendale Building and Safety Code. This amendment adds and clarifies various definitions for terms used within this Chapter. (Justification: Administrative - See justification A in the attached matrix)

Section IA – 29.

[F] 403.3 Combination automatic sprinkler/standpipe system.

This amendment makes the Building Standards in Volume IA of the 2023 Glendale Building and Safety Code consistent with the Fire Safety Standards in Volume VI of the 2023 Glendale Building and Safety Code. This amendment is an administrative amendment only, for consistency. The [F] indicates the language is copied from the Fire Code for consistency. If such amendment to the Fire Code requires further Justification pursuant to HSC 17958 and / or HSC 18941, such justifications are provided with the other local amendments to Title 24, Part 9 contained within this document.

(Justification: Geologic, Climatic, Topographic - See justification B, C, and D in the attached matrix.)

Section IA – 30.

[F] 403.3.3 Secondary water supply.

This amendment makes the Building Standards in Volume IA of the 2023 Glendale Building and Safety Code consistent with the Fire Safety Standards in Volume VI of the 2023 Glendale Building and Safety Code. This amendment is an administrative amendment only, for consistency. The [F] indicates the language is copied from the Fire Code for consistency. If such amendment to the Fire Code requires further Justification pursuant to HSC 17958 and / or HSC 18941, such justifications are provided with the other local amendments to Title 24, Part 9 contained within this document.

(Justification: Geologic, Climatic, Topographic - See justification B, C, and D in the attached matrix.)

Section IA – 31.

503.2 Construction on contiguous lots under same ownership or occupancy.

This amendment is the same as in the 1999, 2002, 2008, 2011, 2014, 2017 and 2020 Glendale Building and Safety Code.

This amendment establishes construction requirements for structures constructed on two or more contiguous lots, when such lots are held under common ownership or occupancy.

(Justification: Administrative - See justification A in the attached matrix)

Section IA – 32.

[F] 903.2.21 Where required.

This amendment makes the Building Standards in Volume IA of the 2023 Glendale Building and Safety Code consistent with the Fire Safety Standards in Volume VI of the 2023 Glendale Building and Safety Code. This amendment is an administrative amendment only, for consistency. The [F] indicates the language is copied from the Fire Code for consistency. If such amendment to the Fire Code requires further Justification pursuant to HSC 17958 and / or HSC 18941, such justifications are provided with the other local amendments to Title 24, Part 9 contained within this document.

(Justification: Administrative, Geologic, Climatic, Topographic - See justification A, B, C, and D in the attached matrix.)

Section IA – 33.

[F] 906.8 Cabinets.

This amendment makes the Building Standards in Volume IA of the 2023 Glendale Building and Safety Code consistent with the Fire Safety Standards in Volume VI of the 2023 Glendale Building and Safety Code. This amendment is an administrative amendment only, for consistency. The [F] indicates the language is copied from the Fire Code for consistency. If such amendment to the Fire Code requires further Justification pursuant to HSC 17958 and / or HSC 18941, such justifications are provided with the other local amendments to Title 24, Part 9 contained within this document.

(Justification: Geologic, Climatic, Topographic - See justification B, C, and D in the attached matrix.)

Section IA – 34.

[F] 906.9.1 Extinguishers weighing 40 pounds or less.

This amendment makes the Building Standards in Volume IA of the 2023 Glendale Building and Safety Code consistent with the Fire Safety Standards in Volume VI of the 2023 Glendale Building and Safety Code. This amendment is an administrative amendment only, for consistency. The [F] indicates the language is copied from the Fire Code for consistency. If such amendment to the Fire Code requires further Justification pursuant to HSC 17958 and / or HSC 18941, such justifications are provided with the other local amendments to Title 24, Part 9 contained within this document.

(Justification: Administrative – See justification A in the attached matrix)

Section IA – 35.

[F] 907.6.6 Monitoring.

This amendment makes the Building Standards in Volume IA of the 2023 Glendale Building and Safety Code consistent with the Fire Safety Standards in Volume VI of the 2023 Glendale Building and Safety Code. This amendment is an administrative amendment only, for consistency. The [F] indicates the language is copied from the Fire Code for consistency. If such amendment to the Fire Code requires further Justification pursuant to HSC 17958 and / or HSC 18941, such justifications are provided with the other local amendments to Title 24, Part 9 contained within this document.

(Justification: Geologic, Climatic, Topographic - See justification B, C, and D in the attached matrix.)

Section IA – 36.

[F] 907.9 Certification and Identification of Certificated Systems.

This amendment makes the Building Standards in Volume IA of the 2023 Glendale Building and Safety Code consistent with the Fire Safety Standards in Volume VI of the 2023 Glendale Building and Safety Code. This amendment is an administrative amendment only, for consistency. The [F] indicates the language is copied from the Fire Code for consistency. If such amendment to the Fire Code requires further Justification pursuant to HSC 17958 and / or HSC 18941, such justifications are provided with the other local amendments to Title 24, Part 9 contained within this document.

(Justification: Administrative - See justification A in the attached matrix.)

Section IA – 37.

[F] 913.7 Fire pumps and pump rooms.

This amendment makes the Building Standards in Volume IA of the 2023 Glendale Building and Safety Code consistent with the Fire Safety Standards in Volume VI of the 2023 Glendale Building and Safety Code. This amendment is an administrative amendment only, for consistency. The [F] indicates the language is copied from the Fire Code for consistency. If such amendment to the Fire Code requires further Justification pursuant to HSC 17958 and / or HSC 18941, such justifications are provided with the other local amendments to Title 24, Part 9 contained within this document.

(Justification: Geologic, Climatic, Topographic - See justification B, C, and D in the attached matrix.)

Section IA – 38.

NOT USED.

Section IA – 39.

NOT USED.

Section IA – 40.

1505.1 General.

This amendment is the same as in the 2008, 2011, 2014, 2017 and 2020 Glendale Building and Safety Code. This amendment prohibits the use of wood roof covering material and requires other roof coverings to have a Class A rating or be made of materials meeting the requirements of a Class B roofing assembly.

(Justification: Topographic and Climatic– See justification C and D in the attached matrix)

Section IA – 41.

TABLE 1505.1.

MINIMUM ROOF COVERING CLASSIFICATION FOR TYPES OF CONSTRUCTION

This amendment is the same as in the 2008, 2011, 2014, 2017 and 2020 Glendale Building and Safety Code.

This amendment eliminates the acceptance of Class C roofing materials.

(Justification: Topographic and Climatic– See justification C and D in the attached matrix)

Section IA – 42.

1505.1.3 Roof coverings within all other areas.

This amendment is the same as in the 2008, 2011, 2014, 2017 and 2020 Glendale Building and Safety Code. This amendment prohibits the use of wood roof covering material and requires other roof coverings to have a Class A rating or be made of materials meeting the requirements of a Class B roofing assembly in non-high fire hazard areas.

(Justification: Topographic and Climatic– See justification C and D in the attached matrix)

Section IA – 43.

1507.3.1 Deck requirements.

This amendment is the same as in the 2014, 2017 and 2020 Glendale Building and Safety Code. This amendment requires concrete and clay tiles to be installed only over solid structural sheathing boards. The change is necessary because there were numerous observations of tile roofs pulling away from wood framed buildings following the 1994 Northridge Earthquake. The SEAOSC/LA City Post Northridge Earthquake committee findings indicated significant problems with tile roofs was due to inadequate design and/or construction. Therefore, the amendment is needed to minimize such occurrences in the event of future significant earthquakes.

(Justification: Geologic and Climatic – see justification B in the attached matrix)

Section IA – 44.

Table 1507.3.7 CLAY AND CONCRETE TILE ATTACHMENT.

This amendment is the same as in the 2008, 2011, 2014, 2017 and 2020 Glendale Building and Safety Code. This amendment changes the minimum number of fasteners for tile roofing material from one fastener to two fasteners per tile even on relatively flat roofs and increases the minimum side lap requirement for roofing felt. This amendment specifies nailing edge distances to ensure a sturdy connection. This amendment also establishes corrosion resistance characteristics for nails to mitigate water intrusion and water-accelerated corrosion of fastening material which results from heavy rains which occur throughout the local region.

(Justification: Geologic and Climatic – see justification B and C in the attached matrix)

Section IA – 45.

1511.7 Roof sheathing.

This amendment is the same as in the 2008, 2011, 2014, 2017 and 2020 Glendale Building and Safety Code, renumbered from Section 1510.8 to match the new code format. This amendment requires existing buildings to be provided with a plywood diaphragm when roofing material is stripped from the structure, if such buildings do not have such a diaphragm,

(Justification: Geologic and Topographic– see justification B and D in the attached matrix)

Section IA – 46.

1613.5 Amendments to ASCE 7.

This amendment is new to the 2020 Glendale Building and Safety Code. The provisions of this section shall be permitted as an amendment to the relevant provisions of ASCE 7.

(Justification: Geologic and Topographic – See justification B and D in the attached matrix)

Section IA – 47.

1613.5.1 Values for Vertical Combinations.

This amendment is the same as in the 2008, 2011, 2014, 2017 and 2020 Glendale Building and Safety Code, renumbered from Sections 1613.5.3 to match the new code format. This amendment is a revision to Section 12.2.3.1 exception 3 12.12-1 of ASCE 7-10 reference document.

Observed damages to one- and two-family dwellings of light frame construction after the Northridge Earthquake may have been partially attributed to vertical irregularities common to this type of occupancy and construction. In an effort to improve quality of construction and incorporate lesson learned from studies after the Northridge Earthquake, the proposed modification to ASCE 7-10 Section 12.2.3.1 Exception 3 by limiting the number of stories and height of the structure to two stories will significantly minimize the impact of vertical irregularities and concentration of inelastic behavior from mixed structural systems.

(Justification: Geologic and Topographic – See justification B and D in the attached matrix)

Section IA – 48.

1613.5.2 Wood Diaphragms.

This amendment is the same as in the 2008, 2011, 2014, 2017 and 2020 Glendale Building and Safety Code, renumbered from Sections 1613.5.4 to match the new code format. This amendment is a revision to Section 12.11.2.2.3 of ASCE 7-10 reference document.

A joint Structural Engineers Association of Southern California (SEAOSC), Los Angeles County and Los Angeles City Task Force investigated the performance of concrete and masonry construction with flexible wood diaphragm failures after the Northridge earthquake. It was concluded at that time that continuous ties are needed at specified spacing to control cross grain tension in the interior of the diaphragm. Additionally, there was a need to limit subdiaphragm allowable shear loads to control combined orthogonal stresses within the diaphragm. Recognizing the importance and need to continue the recommendation made by the task force while taking into consideration the improve performances and standards for diaphragm construction today, this proposal increases the continuous tie spacing limit to 40 ft in lieu of 25 ft and to use 75% of the allowable code diaphragm shear to determine the depth of the sub-diaphragm in lieu of the 300 plf and is deemed appropriate and acceptable. Due to the frequency of this type of failure during the past significant earthquakes, various jurisdictions within the Los Angeles region have taken this additional step to prevent roof or floor diaphragms from pulling away from concrete or masonry walls.

(Justification: Geologic and Topographic – See justification B and D in the attached matrix)

Section IA – 49.

1613.5.3 Structural Separation.

This amendment is the same as in the 2008, 2011, 2014, 2017 and 2020 Glendale Building and Safety Code, renumbered from Sections 1613.5.2 to match the new code format. This amendment is a revision to Section 12.12.3 equation 12.12-1 of ASCE 7-10 reference document.

The inclusion of the importance factor in this equation has the unintended consequence of reducing the minimum seismic separation distance for important facilities such as hospitals, schools, police and fire stations from adjoining structures. The proposal to omit the importance factor from Equation 12.12-1 will ensure that a safe seismic separation distance is provided.

(Justification: Geologic and Topographic – See justification B in the attached matrix)

Section IA – 50.

1613.7 Seismic design provisions for hillside buildings.

This amendment is the same as in the 1999, 2002, 2008, 2011, 2014, 2017 and 2020 Glendale Building and Safety Code, renumbered from Section 1617 to match the new code format. This amendment establishes design parameters to mitigate the increased seismic forces which are imparted upon structures located on sloping surfaces.

Due to the difficulty of fire suppression vehicles accessing winding and narrow hillside properties and the probabilities for future earthquakes in the Los Angeles region, this technical amendment is required to address the special needs for buildings constructed on hillside locations. A joint Structural Engineers Association of Southern California (SEAOSC) and both the Los Angeles County and Los Angeles City Task Force investigated the performance of hillside building failures after the Northridge earthquake. Numerous hillside failures resulted in loss of life and millions of dollars in damage. These criteria were developed to minimize the damage to these structures and have been in use by both the City and County of Los Angeles for several years with much success.

(Justification: Geologic and Topographic– See justification B and D in the attached matrix)

Section IA – 51.

1613.7 Suspended ceilings.

This section is the same as in the 2008, 2011, 2014, 2017 and 2020 Glendale Building and Safety Code, renumbered from Section 1613.7 to match the new code format.

This amendment is necessary to address the design of suspended ceilings for seismic loads similar to what is in the current California Building Code. The California Building Code has little to no information regarding the safe design and construction requirements for ceiling suspension systems subject to seismic loads. It is through the experience of prior earthquakes, such as the Northridge Earthquake, that this amendment is proposed so as to minimize the amount of bodily and building damage within the spaces in which this type of ceiling will be installed. This amendment complements ASCE 7-10 Chapter 13 Section 13.5.6.2.2 and the cited reference to ASTM E580. The amended requirements retained herein are a continuation of portions of an amendment adopted during the previous code adoption cycles.

(Justification: Geologic– See justification B in the attached matrix)

Section IA – 52.

1701.3 Technical specialties

This amendment is the same as in the 2014 and 2017 Glendale Building and Safety Code.

This amendment establishes administrative procedures and requires complex buildings and structures where special expertise is needed as determined by the building official, the building official may require the work to be observed, inspected or certified by a third party, that has certification or has demonstrated expertise in the identified work.

(Justification: Administrative, Geologic, Climatic, Topographic - See justification A, B, C, and D in the attached matrix.)

Section IA – 53.

1704.2 Special inspections and tests.

This amendment is the same as in the 2008, 2011, 2014 and 2017 Glendale Building and Safety Code, renumbered from Section 1704.1 to match the new code format. This amendment deletes an exception for single family dwellings regarding special inspections.

(Justification: Geologic and Topographic – See justification B and D in the attached matrix)

Section IA – 54.

1704.6 Structural Observations.

This amendment is the same as in the 2008, 2011, 2014, 2017 and 2020 Glendale Building and Safety Code, renumbered from Section 1704.6 to match the new code format.

This amendment provides administrative guidelines to establish consistent structural observation procedures, necessary to provide proper structural observation of critical design features in buildings to ensure that they are constructed in accordance with the designer's parameters, to withstand the seismic forces which may be imparted on buildings within this area.

(Justification: Administrative and Geologic– See justification A and B in the attached matrix)

Section IA – 55.

1704.6.1 Structural observations for structures.

This amendment is the same as in the 2008, 2011, 2014, 2017 and 2020 Glendale Building and Safety Code, renumbered from Sections 1704.6.1 to match the new code. This amendment clarifies an exception regarding structural observation for single family dwellings.

With the higher seismic demand placed on buildings and structures in this region, the language in Section 1704.6.1 of the California Building Code would permit many low-rise buildings and structures with complex structural elements to be constructed without the benefit of a structural observation. By requiring a registered design professional to observe the construction, the quality of the observation for major structural elements and connections that affect the vertical and lateral load resisting systems of the structure will greatly be increased. An exception is provided to permit simple structures and buildings to

be excluded. This proposed amendment is a continuation of an amendment adopted during previous code adoption cycles.

(Justification: Geologic – See justification B in the attached matrix)

Section IA – 56.

1705.3 Concrete construction.

This amendment is the same as in the 2008, 2011, 2014, 2017 and 2020 Glendale Building and Safety Code.

This amendment requires special inspection for concrete with a compressive strength over 2500 psi as our code currently requires. Results from studies after the 1994 Northridge Earthquake indicated that significant damage was attributed to a lack of quality control during construction resulting in poor performance of the building or structure. Therefore, the proposed amendment requires special inspection for concrete with a compressive strength greater than 2,500 pounds per square inch. This proposed amendment is a continuation of an amendment adopted during previous code adoption cycles.

(Justification: Geologic and Topographic – See justification B and D in the attached matrix)

Section IA – 57.

1705.12 Special inspections for seismic resistance.

This amendment is similar to the 2011, 2014, 2017 and 2020 Glendale Building and Safety Code, renumbered from Section 1705.11 to match the new code format.

This amendment modifies an exception to require special inspections to detached one-or-two family dwellings located in Seismic Design Category D, E or F.

In southern California, very few detached one- or two-family dwellings not exceeding two stories above grade plane are built as “box-type” structures, especially those in hillside areas. Many steel moment frames or braced frames and/or cantilevered columns within buildings can still be shown as “regular” structures by calculations. With the higher seismic demand placed on buildings and structures in this region, the language in Sections 1705.12 Item 3 of the California Building Code would permit many detached one- or two-family dwellings not exceeding two stories above grade plane with complex structural elements to be constructed without the benefit of special inspections. By requiring special inspections, the quality of major structural elements and connections that affect the vertical and lateral load resisting systems of the structure will greatly be increased.

(Justification: Geologic – See justification B in the attached matrix)

Section IA – 58.

1805.4.3 Drainage discharge.

This amendment is the same as in the 2008, 2011, 2014, 2017 and 2020 Glendale Building and Safety Code. This amendment requires site drainage devices, for all concentrated water, to be installed to the satisfaction of the building official and city engineer. This amendment will reduce damage and help prevent injury by requiring that drainage systems be installed to minimum standards established by the building official and the city engineer, thereby providing better control of the effect of concentrated drainage on property.

(Justification: Climatic and Topographic – see justification C and D in the attached matrix)

Section IA – 59.

1807.1.4 Permanent wood foundation systems.

This amendment is the same as in the 2008, 2011, 2014, 2017 and 2020 Glendale Building and Safety Code. This amendment prohibits the use of spread wood footings. No substantiating data has been provided to show that wood foundation systems are effective in supporting buildings and structures during a seismic event while being subject to deterioration caused by the combined detrimental effects of constant moisture in the soil and wood-destroying organisms. Wood foundation systems not properly treated and protected against deterioration, have performed very poorly and have led to slope failures. Most contractors are typically accustomed to construction in dry and temperate weather in the Southern

California region and are not generally familiar with the necessary precautions and treatment of wood that makes it suitable for both seismic events and wet applications. The proposed amendment takes the precautionary steps to reduce or eliminate potential problems that may result in using wood foundation systems that experience relatively rapid decay due to the fact that the region does not experience temperatures cold enough to destroy or retard the growth and proliferation of wood-destroying organisms. (Justification: Geologic and Climatic - see justification B and C in the attached matrix)

Section IA – 60.

1807.1.6 Prescriptive design of concrete and masonry foundation walls.

This amendment is the same as in the 2008, 2011, 2014, 2017 and 2020 Glendale Building and Safety Code. This amendment requires foundation walls be designed by licensed professionals and deletes references to prescriptive tables which allow plain concrete or excessively slender walls. With the higher seismic demand placed on buildings and structures in this region, it is deemed necessary to take precautionary steps to reduce or eliminate potential problems that may result by following prescriptive design provisions that does not take into consideration the surrounding environment. Plain concrete performs poorly in withstanding the cyclic forces resulting from seismic events. In addition, no substantiating data has been provided to show that under-reinforced foundation walls are effective in resisting seismic loads and may potentially lead to a higher risk of failure. It is important that the benefit and expertise of a registered design professional be obtained to properly analyze the structure and take these issues into consideration.

(Justification: Geologic - see justification B in the attached matrix)

Section IA – 61.

1807.2 Retaining walls.

This amendment is new to the 2020 Glendale Building and Safety Code.

This proposed amendment is a continuation of an amendment adopted during previous code adoption cycles. No substantiating data has provided to show that wood foundation systems are effective in supporting buildings and structures during a seismic event while being subject to deterioration caused by the combined detrimental effects of constant moisture in the soil and wood-destroying organisms. Wood foundation systems not properly treated and protected against deterioration, have performed very poorly and have led to slope failures. Most contractors are typically accustomed to construction in dry and temperate weather in the Southern California region and are not generally familiar with the necessary precautions and treatment of wood that makes it suitable for both seismic events and wet applications. The proposed amendment takes the precautionary steps to reduce or eliminate potential problems that may result in using wood foundation systems that experience relatively rapid decay due to the fact that the region does not experience temperatures cold enough to destroy or retard the growth and proliferation or wood-destroying organisms.

(Justification: Geologic - see justification B in the attached matrix)

Section IA – 62.

1807.3.1 Limitations.

This amendment is new to the 2020 Glendale Building and Safety Code.

This proposed amendment is a continuation of an amendment adopted during previous code adoption cycles. No substantiating data has provided to show that wood foundation systems are effective in supporting buildings and structures during a seismic event while being subject to deterioration caused by the combined detrimental effects of constant moisture in the soil and wood-destroying organisms. Wood foundation systems not properly treated and protected against deterioration, have performed very poorly and have led to slope failures. Most contractors are typically accustomed to construction in dry and temperate weather in the Southern California region and are not generally familiar with the necessary precautions and treatment of wood that makes it suitable for both seismic events and wet applications. The proposed amendment takes the precautionary steps to reduce or eliminate potential problems that may result in using wood foundation systems that experience relatively rapid decay due to the fact that the

region does not experience temperatures cold enough to destroy or retard the growth and proliferation or wood-destroying organisms.

(Justification: Geologic - see justification B in the attached matrix)

Section IA – 63.

1809.3 Stepped Footings.

This amendment is the same as in the 2008, 2011, 2014, 2017 and 2020 Glendale Building and Safety Code.

This amendment clarifies additional reinforcing for stepped footing assigned to higher Seismic Design Category. With the higher seismic demand placed on buildings and structures in this region, precautionary steps are proposed to reduce or eliminate potential problems that may result for under reinforced footings located on sloped surfaces. Requiring minimum reinforcement for stepped footings is intended to address the problem of poor performance of plain or under-reinforced footings during a seismic event.

(Justification: Geologic - See justification B in the attached matrix)

Section IA – 64.

1809.7 Prescriptive footings for light-frame construction.

This amendment is the same as in the 2008, 2011, 2014, 2017 and 2020 Glendale Building and Safety Code, renumbered from Section 1805.4.2. This amendment restricts the use of plain concrete in foundations supporting light frame construction. No substantiating data has been provided to show that under-reinforced footings are effective in resisting seismic loads and may potentially lead to a higher risk of failure. Therefore, this proposed amendment requires minimum reinforcement in continuous footings to address the problem of poor performance of plain or under-reinforced footings during a seismic event. With the higher seismic demand placed on buildings and structures in this region, precautionary steps are proposed to reduce or eliminate potential problems that may result by following prescriptive design provisions for footing that does not take into consideration the surrounding environment. It was important that the benefit and expertise of a registered design professional be obtained to properly analyze the structure and take these issues into consideration. This amendment reflects the recommendations by the Structural Engineers Association of Southern California (SEAOSC) and the Los Angeles City Task Force that investigated the poor performance observed in the 1994 Northridge Earthquake.

(Justification: Geologic - See justification B in the attached matrix)

Section IA – 65.

TABLE 1809.7 PRESCRIPTIVE FOOTINGS SUPPORTING WALLS OF LIGHT-FRAME CONSTRUCTION.

This amendment is the same as in the 2008, 2011, 2014, 2017 and 2020 Glendale Building and Safety Code. This amendment restricts the use of plain concrete in foundations supporting light frame construction. No substantiating data has been provided to show that under-reinforced footings are effective in resisting seismic loads and may potentially lead to a higher risk of failure. Therefore, this proposed amendment requires minimum reinforcement in continuous footings to address the problem of poor performance of plain or under-reinforced footings during a seismic event. With the higher seismic demand placed on buildings and structures in this region, precautionary steps are proposed to reduce or eliminate potential problems that may result by following prescriptive design provisions for footing that does not take into consideration the surrounding environment. It was important that the benefit and expertise of a registered design professional be obtained to properly analyze the structure and take these issues into consideration. This amendment reflects the recommendations by the Structural Engineers Association of Southern California (SEAOSC) and the Los Angeles City Task Force that investigated the poor performance observed in the 1994 Northridge Earthquake.

(Justification: Geologic - See justification B in the attached matrix)

Section IA – 66.

1809.12 Timber footings.

This amendment is the same as in the 2008, 2011, 2014, 2017 and 2020 Glendale Building and Safety Code. This amendment prohibits the use of timber footings.

No substantiating data has been provided to show that timber footings are effective in supporting buildings and structures during a seismic event, especially while being subjected to deterioration caused by the combined detrimental effects of moisture in the soil and wood-destroying organisms. Timber footings, when they are not properly treated and protected against deterioration, have performed very poorly. Most contractors are typically accustomed to construction in dry and temperate weather in the Southern California region and are not generally familiar with the necessary precautions and treatment of wood that makes it suitable for both seismic event and wet applications. The proposed amendment takes the precautionary steps to reduce or eliminate potential problems that may result by using timber footings that experience relatively rapid decay due to the fact that the region does not experience temperatures cold enough to destroy or retard the growth and proliferation of wood-destroying organisms.

(Justification: Geologic and Climatic - See justification B and C in the attached matrix)

Section IA – 67.

1810.3.2.4 Timber.

This amendment is similar to the 2008, 2011, 2014, 2017 and 2020 Glendale Building and Safety Code. This amendment prohibits the use of timber footings.

No substantiating data has been provided to show that timber deep foundation is effective in supporting buildings and structures during a seismic event while being subject to deterioration caused by the combined detrimental effect of constant moisture in the soil and wood-destroying organisms. Timber deep foundation, when they are not properly treated and protected against deterioration, has performed very poorly. Most contractors are typically accustomed to construction in dry and temperate weather in the Southern California region and are not generally familiar with the necessary precautions and treatment of wood that makes it suitable for both seismic event and wet applications. The proposed amendment takes the precautionary steps to reduce or eliminate potential problems that may result by using timber deep foundation that experience relatively rapid decay due to the fact that the region does not experience temperatures cold enough to destroy or retard the growth and proliferation of wood-destroying organisms.

(Justification: Geologic and Climatic - See justification B and C in the attached matrix)

Section IA – 68.

1905.1 General.

This amendment is similar to the 2008, 2011, 2014, 2017 and 2020 Glendale Building and Safety Code, to add sections necessary to address deficiencies in ACI 318, as described in the adoption of Sections IA – 69 through IA- 72. If such amendment to the Building Code requires further Justification pursuant to HSC 17958 and / or HSC 18941, such justifications are provided with the pursuant sub-sections.

(Justification: Geologic- See justification A in the attached matrix)

Section IA – 69.

1905.1.7 ACI 318 Section 14.1.4.

This amendment is the same as in the 2011, 2014, 2017 and 2020 Glendale Building and Safety Code, renumbered from Sections 1905.1.8 to match the new code. This amendment addresses a deficiency in ACI 318.

This proposed amendment requires minimum reinforcement in continuous footings to address the problem of poor performance of plain or under-reinforced footings during a seismic event. This amendment reflects the recommendations by the Structural Engineers Association of Southern California (SEAOSC) and the Los Angeles City Joint Task Force that investigated the poor performance observed in 1994 Northridge Earthquake.

(Justification: Geologic- See justification B in the attached matrix)

Section IA – 70.

1905.1.9 ACI 318 Section 18.7.5.

This amendment is the same as in the 2008, 2011, 2014, 2017 and 2020 Glendale Building and Safety Code, renumbered from Section 1905.1.10 and to address a deficiency in ACI 318. This amendment was renumbered from Section 1908.1.11 and ACI 318 Section 21.6.4.1. This amendment is intended to carry over critical provisions for the design of concrete columns in moment frames from the legacy 1997 Uniform Building Code. Increased confinement is critical to the integrity of such columns and these modifications ensure that it is provided when certain thresholds are exceeded.

(Justification: Geologic- See justification B in the attached matrix)

Section IA – 71.

1905.1.10 ACI 318 Section 18.10.4.

This amendment is the same as in the 2008, 2011, 2014, 2017 and 2020 Glendale Building and Safety Code, renumbered from Section 1905.1.11 and to address a deficiency in ACI 318. This amendment was renumbered from Section 1908.1.12. This amendment carries over from the legacy 1997 Uniform Building Code a critical provision for the design of concrete shear walls. It essentially limits the use of very highly gravity-loaded walls in being included in the seismic load resisting system, since their failure could have catastrophic effect on the building.

(Justification: Geologic- See justification B in the attached matrix)

Section IA – 72.

1905.1.11 ACI 318 Section 18.12.6.

This amendment is the same as in the 2008, 2011, 2014, 2017 and 2020 Glendale Building and Safety Code, renumbered from Section 1905.1.12 and to address a deficiency in ACI 318. This amendment was renumbered from Section 1908.1.13. This amendment was incorporated in the code based on observations from the 1994 Northridge Earthquake. Rebar placed in very thin concrete topping slabs have been observed in some instances to have popped out of the slab due to insufficient concrete coverage. This modification ensures that critical boundary and collector reinforcing bars are placed in sufficiently thick topping slab to prevent buckling of such reinforcements.

(Justification: Geologic - See justification B in the attached matrix)

Section IA – 73.

2113.1 General.

This amendment is the same as in the 2011, 2014, 2017 and 2020 Glendale Building and Safety Code. It defines the requirements for a partial repair of an existing masonry chimney.

(Justification: ~~Administrative~~ Geologic - See justification ~~A~~ B in the attached matrix)

Section IA – 74.

2304.10.2 Fastener Requirements.

This amendment is the same as in the 2008, 2011, 2014, 2017 and 2020 Glendale Building and Safety Code, renumbered from Section 2304.9.1 to match the new code format.

This amendment prohibits the use of staples as fasteners to resist or transfer seismic forces and shall not be permitted without being substantiated by cyclic testing. Due to the high geologic activities in the Southern California area and the expected higher level of performance on buildings and structures, this proposed local amendment limit the use of staple fasteners in resisting or transferring seismic forces. In September 2007, limited cyclic testing data was provided to the ICC Los Angeles Chapter Structural Code Committee showing that stapled wood structural shear panels do not exhibit the same behavior as the nailed wood structural shear panels. The test results of the stapled wood structural shear panels appeared much lower in strength and drift than the nailed wood structural shear panel test results. Therefore, the use of staples as fasteners to resist or transfer seismic forces shall not be permitted without being substantiated by cyclic testing.

(Justification: Geologic - See justification B in the attached matrix)

Section IA – 75.

2304.10.3.1 Quality of nails.

This amendment is the same as in the 2008, 2011, 2014, 2017 and 2020 Glendale Building and Safety Code.

The overdriving of nails into the structural wood panel still remains a concern when pneumatic nail guns are used for wood structural panel shear wall nailing. Box nails were observed to cause massive and multiple failures of the typical 3/8-inch thick plywood during the 1994 Northridge Earthquake. The use of clipped head nails as allowed in Table A1 of AFPA SDPWS footnote referencing to ASTM F1667, continues to be restricted from being used in wood structural panel shear walls where the minimum nail head size must be maintained in order to minimize nails from pulling through sheathing materials. Clipped or mechanically driven nails used in wood structural panel shear wall construction were found to perform much less in previous wood structural panel shear wall testing done at the University of California Irvine. The existing test results indicated that, under cyclic loading, the wood structural panel shear walls were less energy absorbent and less ductile. The panels reached ultimate load capacity and failed at substantially less lateral deflection than those using same size hand-driven nails. This amendment reflects the recommendations by the Structural Engineers Association of Southern California (SEAOSC) and the Los Angeles City Joint Task Force that investigated the poor performance observed in 1994 Northridge Earthquake. (Justification: Geologic- See justification B in the attached matrix)

Section IA – 76.

2304.12.2.8 Wood used in retaining walls and cribs.

This amendment is the same as in the 2014, 2017 and 2020 Glendale Building and Safety Code to address a design deficiency not addressed in the base code, renumbered from Section 2304.11.7 to match the new code format.

No substantiating data has been provided to show that wood used in retaining or crib walls are effective in supporting buildings and structures during a seismic event while being subject to deterioration caused by the combined detrimental effect of constant moisture in the soil and wood-destroying organisms. Wood used in retaining or crib walls, when they are not properly treated and protected against deterioration, have performed very poorly. Most contractors are typically accustomed to construction in dry and temperate weather in the Southern California region and are not generally familiar with the necessary precautions and treatment of wood that makes it suitable for both seismic event and wet applications. The proposed amendment takes the precautionary steps to reduce or eliminate potential problems that may result by using wood in retaining or crib walls that experience relatively rapid decay due to the fact that the region does not experience temperatures cold enough to destroy or retard the growth and proliferation of wood-destroying organisms.

(Justification: Geologic - See justification B and C in the attached matrix)

Section IA – 77.

2305.4 Hold-down connectors.

This amendment is the same as in the 1999, 2002, 2008, 20011, 2014, 2017 and 2020 Glendale Building and Safety Code. This amendment requires seismic hold-down connectors to be designed based on cyclic load values, or 75 percent of non-cyclic load values. Additionally, steel plate washers are required when connection involves wood framing members.

ICC-ES AC 155 Acceptance Criteria for Hold-downs (Tie-Downs) Attached to Wood Members is widely used to establish allowable values for hold-down connectors in evaluation reports. AC 155 uses monotonic loading to establish allowable values. Yet, cyclic and dynamic forces imparted on buildings and structures by seismic activity cause more damage than equivalent forces that are applied in a monotonic manner. However, the engineering, regulatory and manufacturing industries have not reached consensus on the appropriate cyclic or dynamic testing protocols. This condition is expected to continue for some time. In the interim, this proposed amendment continues to limit the allowable capacity to 75% of the evaluation report value to provide an additional factor of safety for statically tested anchorage devices. Steel plate washers will reduce the additional damage that can result when hold-down connectors

are fastened to wood framing members. This amendment reflects the recommendations by the Structural Engineers Association of Southern California (SEAOSC) and the Los Angeles City Joint Task Force that investigated the poor performance observed in 1994 Northridge Earthquake.
(Justification: Geologic - See justification B in the attached matrix)

Section IA – 78.

2306.2 Wood-frame diaphragms.

This amendment is the same as in the 2008, 2011, 2014, 2017 and 2020 Glendale Building and Safety Code.

This amendment disallows the use of higher allowable (horizontal) diaphragm shear stress based on numerical calculation and requires the use of unit shear strength values as specified by the Code. The Structural Engineers Association of Southern California (SEAOSC) and the Los Angeles City Joint Task Force that investigated the damages to buildings and structures during the 1994 Northridge Earthquake recommended reducing allowable shear values in wood structural panel shear walls or diaphragms that are not substantiated by cyclic testing. That recommendation was consistent with a report to the Governor from the Seismic Safety Commission of the State of California recommending that code requirements be "more thoroughly substantiated with testing." The allowable shear values for wood structural panel shear walls or diaphragms fastened with staples are based on monotonic testing and does not take into consideration that earthquake forces load shear wall or diaphragm in a repeating and fully reversible manner.

In September 2007, limited cyclic testing was conducted by a private engineering firm to determine if wood structural panels fastened with staples would exhibit the same behavior as the wood structural panels fastened with common nails. The test result revealed that wood structural panel fastened with staples appeared to be much lower in strength and stiffness than wood structural panels fastened with common nails. It was recommended that the use of staples as fasteners for wood structural panel shear walls or diaphragms not be permitted to resist seismic forces in structures assigned to Seismic Design Category D, E and F unless it can be substantiated by cyclic testing.

Furthermore, the cities and county within the Los Angeles region has taken extra measures to maintain the structural integrity of the framing of shear walls and diaphragms designed for high levels of seismic forces by requiring wood sheathing be applied directly over the framing members and prohibiting the use of panels placed over gypsum sheathing. This proposed amendment is intended to prevent the undesirable performance of nails when gypsum board softens due to cyclic earthquake displacements and the nail ultimately does not have any engagement in a solid material within the thickness of the gypsum board.

(Justification: Geologic- See justification B in the attached matrix)

Section IA – 79.

2306.3 Wood-frame shear walls.

This amendment is the same as in the 2002, 2008, 2011, 2014, 2017 and 2020 Glendale Building and Safety Code.

This amendment disallows the use of higher allowable diaphragm shear stress based on numerical calculation and requires the use of unit shear strength values as specified by the Code. This amendment also limits the minimum thickness of wood structural panel sheathing and establishes minimum nail spacing requirements. This amendment is necessary because unit shear strength values specified in the Code are based on actual cyclic tests, thereby providing a more reliable design strength. Furthermore, review of actual damage caused by recent earthquakes has revealed that diaphragms sheathed with thinner wood structural panels performed poorly and may have contributed to increased structural damage.

(Justification: Geologic- See justification B in the attached matrix)

Section IA – 80.

2307.2 Wood-frame shear walls.

This amendment is the same as in the 2020 Glendale Building and Safety Code.

This proposed amendment continues the previous amendment adopted during the 2010 code adoption cycle.

The greater Los Angeles region is a densely populated area having buildings and structures constructed over and near a vast array of fault systems capable of producing major earthquakes, including but not limited to the recent 1994 Northridge Earthquake. The proposed modification to place design and construction limits on stapled nail fasteners used in wood structural panel shear walls or diaphragms not substantiated with cyclic testing will help to maintain minimum quality of construction and performance standards of structures and therefore need to be incorporated into the code to assure that new buildings and structures and additions or alterations to existing buildings or structures are designed and constructed in accordance with the scope and objectives of the International Building Code.

(Justification: Geologic- See justification B in the attached matrix)

Section IA – 81.

TABLE 2308.6.1 WALL BRACING REQUIREMENTS.

This amendment is the same as in the 2014, 2017 and 2020 Glendale Building and Safety Code to address a design deficiency not addressed in the base code, renumbered from Section 2309.3.1 to match the new code format.

During the Northridge Earthquake, 3/8” thick, 3 ply-plywood shear walls experienced many failures. Box nails were observed to cause massive and multiple failures of the typical 3/8” thick 3-ply plywood during the Northridge Earthquake. This proposed amendment specifies minimum sheathing thickness, nail size and spacing so as to provide a uniform standard of construction for designers and buildings to follow.

This is intended to improve the performance level of buildings and structures that are subject to the higher seismic demands and reduce and limit potential damages to property. This proposed amendment reflects the recommendations by the Structural Engineers Association of Southern California (SEAOSC) and the Los Angeles City Joint Task Force that investigated the poor performance observed in 1994 Northridge Earthquake.

(Justification: Geologic See justification B in the attached matrix)

Section IA – 82.

2308.6.5.1 Alternative braced wall (ABW).

This amendment is the same as in the 2014, 2017 and 2020 Glendale Building and Safety Code to address a design deficiency not addressed in the base code, renumbered from Section 2309.3.1 to match the new code format.

During the Northridge Earthquake, 3/8” thick, 3 ply-plywood shear walls experienced many failures. Box nails were observed to cause massive and multiple failures of the typical 3/8” thick 3-ply plywood during the Northridge Earthquake. This proposed amendment specifies minimum sheathing thickness, nail size and spacing so as to provide a uniform standard of construction for designers and buildings to follow.

This is intended to improve the performance level of buildings and structures that are subject to the higher seismic demands and reduce and limit potential damages to property. This proposed amendment reflects the recommendations by the Structural Engineers Association of Southern California (SEAOSC) and the Los Angeles City Joint Task Force that investigated the poor performance observed in 1994 Northridge Earthquake.

(Justification: Geologic See justification B in the attached matrix)

Section IA – 83.

Figure 2308.6.5.1 ALTERNATE BRACED WALL PANEL (ABW).

This amendment is the same as in the 2014, 2017 and 2020 Glendale Building and Safety Code to address a design deficiency not addressed in the base code, renumbered from Section 2309.3.1 to match the new code format.

During the Northridge Earthquake, 3/8” thick, 3 ply-plywood shear walls experienced many failures. Box nails were observed to cause massive and multiple failures of the typical 3/8” thick 3-ply plywood during the Northridge Earthquake. This proposed amendment specifies minimum sheathing thickness, nail size and spacing so as to provide a uniform standard of construction for designers and buildings to follow.

This is intended to improve the performance level of buildings and structures that are subject to the higher seismic demands and reduce and limit potential damages to property. This proposed amendment reflects the recommendations by the Structural Engineers Association of Southern California (SEAOSC) and the Los Angeles City Joint Task Force that investigated the poor performance observed in 1994 Northridge Earthquake.

(Justification: Geologic See justification B in the attached matrix)

Section IA – 84.

2308.6.5.2 Portal frame with hold-downs (PFH).

This amendment is the same as in the 2014, 2017 and 2020 Glendale Building and Safety Code to address a design deficiency not addressed in the base code, renumbered from Section 2309.3.1 to match the new code format.

During the Northridge Earthquake, 3/8” thick, 3 ply-plywood shear walls experienced many failures. Box nails were observed to cause massive and multiple failures of the typical 3/8” thick 3-ply plywood during the Northridge Earthquake. This proposed amendment specifies minimum sheathing thickness, nail size and spacing so as to provide a uniform standard of construction for designers and buildings to follow.

This is intended to improve the performance level of buildings and structures that are subject to the higher seismic demands and reduce and limit potential damages to property. This proposed amendment reflects the recommendations by the Structural Engineers Association of Southern California (SEAOSC) and the Los Angeles City Joint Task Force that investigated the poor performance observed in 1994 Northridge Earthquake.

(Justification: Geologic See justification B in the attached matrix)

Section IA – 85.

Figure 2308.6.5.2 PORTAL FRAME WITH HOLD-DOWNS (PFH).

This amendment is the same in the 2014, 2017 and 2020 Glendale Building and Safety Code to address a design deficiency not addressed in the base code, renumbered from Section 2309.3.1 to match the new code format.

During the Northridge Earthquake, 3/8” thick, 3 ply-plywood shear walls experienced many failures. Box nails were observed to cause massive and multiple failures of the typical 3/8” thick 3-ply plywood during the Northridge Earthquake. This proposed amendment specifies minimum sheathing thickness, nail size and spacing so as to provide a uniform standard of construction for designers and buildings to follow.

This is intended to improve the performance level of buildings and structures that are subject to the higher seismic demands and reduce and limit potential damages to property. This proposed amendment reflects the recommendations by the Structural Engineers Association of Southern California (SEAOSC) and the Los Angeles City Joint Task Force that investigated the poor performance observed in 1994 Northridge Earthquake.

(Justification: Geologic See justification B in the attached matrix)

Section IA – 86.

2308.6.8.1 Foundation requirements.

This amendment is similar to the 1999, 2002, 2008, 2011, 2014, 2017 and 2020 Glendale Building and Safety Code, renumbered from Section 2308.3.4 to match the new code format.

This amendment requires interior braced walls (shear walls) to be supported by continuous foundations, thereby ensuring a substantial means of transferring loads to the supporting material.

With the higher seismic demand placed on buildings and structures in this region, interior walls can easily be called upon to resist over half of the seismic loading imposed on simple buildings or structures.

Without a continuous foundation to support the braced wall line, seismic loads would be transferred through other elements such as non-structural concrete slab floors, wood floors, etc. The proposed change is to limit the use of the exception to structures assigned to Seismic Design Category A, B or C where lower seismic demands are expected. Requiring interior braced walls be supported by continuous foundations is intended to reduce or eliminate the poor performance of buildings or structures. This proposed amendment is a continuation of an amendment adopted during previous code adoption cycles. (Justification: Geologic See justification B in the attached matrix)

Section IA – 87.

2308.6.9 Attachment of sheathing.

This amendment is the same as in the 2008, 2011, 2104, 2017 and 2020 Glendale Building and Safety Code, renumbered from 2308.12.5 to match the new code format.

This amendment eliminates a provision which would otherwise allow reduced nailing of floor diaphragm sheathing when wood structural panel floors are glued to joists. This proposed amendment is intended to improve the performance level of buildings and structures that are subject to the higher seismic demands placed on buildings or structure in this region. This proposed amendment reflects the recommendations by the Structural Engineers Association of Southern California (SEAOSC) and the Los Angeles City Joint Task Force that investigated the poor performance observed in 1994 Northridge Earthquake.

(Justification: Geologic - See justification B in the attached matrix)

Section IA – 88.

3101.1 Scope.

This amendment is the same as in the 2017 and 2020 Glendale Building and Safety Code.

This amendment is based on similar code provision adopted into the 2021 Edition of the International Building Code. It is intended to assist code officials address the environmental impact of unused materials, reduce consumption of traditional raw materials, minimize non-industrial waste, and ensure minimum design and safety standards associated with the repurposing of existing intermodal shipping containers as buildings or structures or component of buildings and structures are achieved.

(Justification: Administrative and Topographic - See justification A and D in the attached matrix)

Section IA – 89.

3102.2.3 Membrane Structures Used as Shade Covers for Specific Uses.

This amendment makes the Building Standards in Volume IA of the 2023 Glendale Building and Safety Code consistent with the Fire Safety Standards in Volume VI of the 2023 Glendale Building and Safety Code. This amendment is an administrative amendment only, for consistency. This amendment will help expedite Building and Safety’s plan review process.

(Justification: Geologic, Climatic, Topographic - See justification B, C, and D in the attached matrix.)

Section IA – 90.

3102.6.2 Membrane less than 20 feet (6096 mm).

This amendment is the same as in the 2011, 2014, 2017 and 2020 Glendale Building and Safety Code. This amendment codifies conditions of approvals for a building code modification to allow membranes less than 20 feet above finish floor. This amendment will help expedite Building and Safety's plan review process.

(Justification: Administrative and Topographic - See justification A and D in the attached matrix)

Section IA – 91.

3109.4.4.2 Construction permit; safety features required.

This amendment is the same as in the 2014, 2017 and 2020 Glendale Building and Safety Code. This amendment modifies the requirements for swimming pool alarms at residences in hillside locations. This amendment requires the plan review and permitting of swimming pool alarms on a case-by-case basis to ensure that the proposed swimming pool alarm design meets the intent of the code, given the remoteness and topographical conditions surrounding the residence and or pool location.

(Justification: Topographic see justification D in the attached matrix)

Section IA – 92.

3109.4.4.3 Enclosure; required characteristic.

This amendment is the same as in the 1999, 2002, 2008, 2011, 2014, 2017 and 2020 Glendale Building and Safety Code. This amendment modifies the requirements for swimming pool enclosures in a hillside location.

(Justification: Topographic see justification D in the attached matrix)

Section IA – 93.

3115 Intermodal Shipping Containers.

This amendment is new to the 2020 Glendale Building and Safety Code.

This amendment is based on similar code provision adopted into the 2021 Edition of the International Building Code. It is intended to assist code officials address the environmental impact of unused materials, reduce consumption of traditional raw materials, minimize non-industrial waste, and ensure minimum design and safety standards associated with the repurposing of existing intermodal shipping containers as buildings or structures or component of buildings and structures are achieved.

(Justification: Administrative and Topographic - See justification A and D in the attached matrix)

Section IA – 94.

3202.1.2.1 Change of use/occupancy.

This amendment is the same as in the 2011, 2014, 2017 and 2020 Glendale Building and Safety Code. This amendment establishes additional requirements for work to existing structures below grade within the public right of way which is not addressed in the 2016 California Building Code.

(Justification: Administrative and Topographic - See justifications A or D in the attached matrix)

Section IA – 95.

3202.3.2 Windows, architectural features and mechanical equipment.

This amendment is the same as in the 2014, 2017 and 2020 Glendale Building and Safety Code.

This amendment prohibits the encroachment of balconies into the public right-of-way.

(Justification: Administrative - See justifications A in the attached matrix)

Section IA – 96.

3203 PROJECTIONS INTO ALLEYS.

This amendment is the same as in 2014, 2017 and 2020 California Building Code. This amendment establishes additional requirements for work below grade and above grade within the public right-of-way of alleys.

This amendment prohibits part of any structure or appendage to project into any alley with an exception of footings located at least 8 feet below grade may project no more than 12 inches.

(Justification: Administrative and Topographic - See justifications A and D in the attached matrix)

Section IA – 97.

3303.8 Storm water drainage and retention during demolition.

This amendment is the same as in the 2017 and 2020 Glendale Building and Safety Code.

This amendment establishes administrative regulations and contributes to current states mandated storm water drainage and retention objectives during construction.

This amendment is necessary to clarify storm water drainage and retention as mandated by the state shall also be provided during the demolition phase of construction.

(Justification: Administrative, Climatic, Topographic - See justification A, C, and D in the attached matrix.)

Section IA – 98.

3306.2 Walkways.

This amendment is the same as in the 1999, 2002, 2008, 2011, 2014, 2017 and 2020 Glendale Building and Safety Code.

This amendment establishes administrative regulations regarding the construction of protective walkways adjacent to construction sites.

(Justification: Administrative See justification A in the attached matrix)

Section IA – 99.

3306.9.1 Shoring.

This amendment is the same as in the 2002, 2008, 2011, 2014, 2017 and 2020 Glendale Building and Safety Code.

This amendment establishes administrative regulations regarding the construction of shoring to protect the public right-of-way.

(Justification: Administrative - See justification A in the attached matrix)

Section IA – 100.

3306.10 Protection of sidewalk excavations.

This amendment is the same as in the 1999, 2002, 2008, 2011, 2014, 2017 and 2020 Glendale Building and Safety Code.

This amendment establishes administrative regulations regarding excavations within the public right-of-way or other public property.

(Justification: Administrative - See justification A in the attached matrix)

Section IA – 101.

3306.11 Protection of Obstructions.

This amendment is the same as in the 1999, 2002, 2008, 2011, 2014, 2017 and 2020 Glendale Building and Safety Code.

This amendment establishes administrative regulations regarding the placement of protective barriers to prevent accidents resulting from excavations or obstructions within the public right-of-way.

(Justification: Administrative - See justification A in the attached matrix)

Section IA – 102.

3308.3 Street Use Permits.

This amendment is the same as in the 1999, 2002, 2008, 2011, 2014, 2017 and 2020 Glendale Building and Safety Code.

This amendment establishes administrative regulations regarding the use of the public right-of-way.

(Justification: Administrative - See justification A in the attached matrix)

Section IA – 103.

3308.4 Mixing mortar on public property.

This amendment is the same as in the 1999, 2002, 2008, 2011, 2014, 2017 and 2020 Glendale Building and Safety Code.

This amendment establishes administrative regulations regarding the use of public property to mix mortar, concrete or similar material.

(Justification: Administrative - See justification A in the attached matrix)

Section IA – 104.

NOT USED.

Section IA – 105.

Appendix I PATIO COVERS.

This amendment is the same as in the 2014, 2017 and 2020 Glendale Building and Safety Code.

This amendment adopts Appendix Chapter I which permits patio covers meeting the requirements of the appendix section to be designed for different loads than the residence to which it is accessory.

(Justification: Administrative - See justification A in the attached matrix)

Section IA – 106.

Appendix I1505.1 Design loads.

This amendment is the same as in the 2014, 2017 and 2020 Glendale Building and Safety Code.

This amendment prohibits the installation of any solar energy systems on patio covers designed by this section.

(Justification: Geologic and Topographic – See justification B and D in the attached matrix)

Section IA – 107.

Appendix J. GRADING.

This amendment is essentially the same as in the 2011, 2014, 2017 and 2020 Glendale Building and Safety Code.

This amendment establishes grading standards for the 2023 Glendale Building and Safety Code by adopting and amending Appendix Chapter J of the 2022 California Building Code (CBC). In general, the basic grading standards are similar, but not identical, to previous standards. Local amendments are proposed where such amendments are deemed necessary to provide adequate protection from personal injury and property protection due to specific local conditions.

(Justification: Administrative, Geologic, Climatic and Topographic - See justifications E, F, G and H in the attached matrix.)

Section IA – 108.

Appendix J101.1 Scope.

This amendment is the same as in the 2008, 2011, 2014, 2017 and 2020 Glendale Building and Safety Code.

This amendment clarifies the scope of the Glendale Building and Safety Code pertaining to grading. (Justification: Administrative - See justification E in the attached matrix.)

Section IA – 109.

Appendix J101.3 Hazards.

This amendment is the same as in the 2008, 2011, 2014, 2017 and 2020 Glendale Building and Safety Code.

This amendment adds administrative standards to regulate the manner in which hazardous grading conditions must be addressed.

(Justification: Administrative - See justification E in the attached matrix.)

Section IA – 110.

Appendix J101.4 Safety precautions.

This amendment is the same as in the 2008, 2011, 2014, 2017 and 2020 Glendale Building and Safety Code.

This amendment adds administrative standards to establish minimum standards which are necessary to ensure that grading operations are conducted in a safe manner and establishes the authority for the building official to require a property owner to correct and/or abate unacceptable grading conditions. This amendment also identifies areas of the City that are subject to specific hillside grading standards. (Justification: Administrative - See justification E in the attached matrix.)

Section IA – 111.

Appendix J101.5 Protection of utilities.

This amendment is the same as in the 2008, 2011, 2014, 2017 and 2020 Glendale Building and Safety Code.

This amendment adds administrative standards to establish the permittee's responsibility related to protection of utilities during all grading operations. Such express responsibility is not contained within the model International Building Code (IBC).

(Justification: Administrative - See justification E in the attached matrix.)

Section IA – 112.

Appendix J101.6 Protection of adjacent property.

This amendment is the same as in the 2008, 2011, 2014, 2017 and 2020 Glendale Building and Safety Code.

This amendment adds administrative standards to establish the permittee's responsibility related to protection of adjacent property during all grading operations. Such express responsibility is not contained within the model International Building Code (IBC).

(Justification: Administrative – See justification E in the attached matrix.)

Section IA – 113.

Appendix J101.7 Storm water control measures.

This amendment is the same as in the 2008, 2011, 2014, 2017 and 2020 Glendale Building and Safety Code.

This amendment adds administrative standards and construction standards to establish the permittee's responsibility related to control of storm water contamination. This amendment ensures that grading operations are conducted in a manner that is consistent with mandatory requirements under regional and federal storm water protection statutes.

(Justification: Administrative and Climatic - See justifications E and G in the attached matrix.)

Section IA – 114.

Appendix J101.8 Conditions of approval.

This amendment is the same as in the 2008, 2011, 2014, 2017 and 2020 Glendale Building and Safety Code.

This amendment adds administrative standards to establish standard conditions of approval for all grading permits.

(Justification: Administrative - See justification E in the attached matrix.)

Section IA – 115.

Appendix J101.9 Rules and regulations.

This amendment is the same as in the 2008, 2011, 2014, 2017 and 2020 Glendale Building and Safety Code.

This amendment adds administrative standards to establish standard rules and regulations that apply to the issuance of all grading permits. This amendment establishes the preemptive application of more restrictive standards when multiple, conflicting standards exist.

(Justification: Administrative - See justification E in the attached matrix.)

Section IA – 116.

Appendix J102 DEFINITIONS.

This amendment is the same as in the 2008, 2011, 2014, 2017 and 2020 Glendale Building and Safety Code.

This amendment adds and clarifies various definitions for terms used within Appendix Chapter J.

(Justification: Administrative - See justification E in the attached matrix.)

Section IA – 117.

Appendix J103.1 Permits required.

This amendment is the same as in the 2008, 2011, 2014, 2017 and 2020 Glendale Building and Safety Code.

This amendment adds and modifies administrative standards pertaining to permit requirements for grading operations.

(Justification: Administrative - See justification E in the attached matrix.)

Section IA – 118.

Appendix J103.2 Exemptions.

This amendment is the same as in the 2008, 2011, 2014, 2017 and 2020 Glendale Building and Safety Code.

This amendment adds and modifies the types of projects which are exempt from grading permit requirements. In general, the types of grading projects for which a grading permit is not required are similar to exempted projects under the 2008 Glendale Building and Safety Code.

(Justification: Administrative - See justification E in the attached matrix.)

Section IA – 119.

Appendix J103.3 Unpermitted grading.

This amendment is the same as in the 2008, 2011, 2014, 2017 and 2020 Glendale Building and Safety Code.

This amendment establishes administrative standards, including the permittee's responsibility, pertaining to grading operations that are performed which exceed the scope of a validly issued grading permit.

(Justification: Administrative - See justification E in the attached matrix.)

Section IA – 120.

Appendix J103.4 Grading fees.

This amendment is the same as in the 2008, 2011, 2014, 2017 and 2020 Glendale Building and Safety Code.

This amendment establishes administrative standards necessary to determine fees that are associated with grading plan check and grading permit issuance. Furthermore, this amendment establishes said fees by resolution of the City Council.

(Justification: Administrative - See justification E in the attached matrix.)

Section IA – 121.

Appendix J103.5 Bonds and insurance.

This amendment is the same as in the 2008, 2011, 2014, 2017 and 2020 Glendale Building and Safety Code.

This amendment establishes various administrative standards related to grading bonds that are required as a condition of permit issuance.

(Justification: Administrative - See justification E in the attached matrix.)

Section IA – 122.

Appendix J104.2 Grading plan requirements.

This amendment is the same as in the 2008, 2011, 2014, 2017 and 2020 Glendale Building and Safety Code.

This amendment establishes administrative requirements related to information required on grading plans.

(Justification: Administrative - See justification E in the attached matrix.)

Section IA – 123.

Appendix J104.2.1 Grading designation.

This amendment is the same as in the 2008, 2011, 2014, 2017 and 2020 Glendale Building and Safety Code.

This amendment establishes administrative and technical standards related to grading plan requirements for projects that are located within hillside areas (mountainous terrain) or exceeding 5,000 cubic yards in all other areas. Projects that are located within hillside areas or which exceed 5,000 cubic yards shall comply with “engineered grading” standards.

(Justification: Administrative, Geologic, Climatic and Topographic - See justifications E, F, G and H in the attached matrix.)

Section IA – 124.

Appendix J104.2.2 Regular grading requirements.

This amendment is the same as in the 2014, 2017 and 2020 Glendale Building and Safety Code.

This amendment establishes administrative and technical standards related to grading plan requirements for projects that are not located within hillside areas (mountainous terrain) or involve less than 5,000 cubic yards in all other areas. Projects that are not located within hillside areas and which involve less than 5,000 cubic yards shall comply with “regular grading” standards. This amendment also clarifies a licensed professional shall prepare such grading plans for projects which slope of grade exceeds 3:1.

(Justification: Administrative, Geologic, Climatic and Topographic – See justifications E, F, G and H in the attached matrix.)

Section IA – 125.

Appendix J104.2.3 Engineered grading requirements.

This amendment is the same as in the 2008, 2011, 2014, 2017 and 2020 Glendale Building and Safety Code.

This amendment establishes administrative and technical standards related to grading plan requirements for projects that are located within hillside areas (mountainous terrain) or exceeding 5,000 cubic yards in all other areas. Projects that are located within hillside areas or which exceed 5,000 cubic yards shall comply with “engineered grading” standards.

(Justification: Administrative, Geologic, Climatic and Topographic - See justifications E, F, G and H in the attached matrix)

Section IA – 126.

Appendix J104.3 Geotechnical engineering and engineering geology report.

This amendment is the same as in the 2011, 2014, 2017 and 2020 Glendale Building and Safety Code.

This amendment identifies that a geotechnical report shall be required on all projects requiring a grading permit.

This amendment establishes minimum requirements for information that is to be included in soils engineering and engineering geology reports, by adding additional requirements beyond what is required under the 2019 California Building Code (CBC).

(Justification: Administrative, Geologic, Climatic and Topographic - See justifications E, F, G and H in the attached matrix.)

Section IA – 127.

Appendix J104.4 Liquefaction study.

This amendment is the same as in the 2008, 2011, 2014, 2017 and 2020 Glendale Building and Safety Code.

This amendment establishes parameters to identify when a liquefaction study is required. These amended standards are consistent with state-mandated requirements associated with the California Seismic Hazard Map Act.

(Justification: Geologic and Topographic - See justifications F and H in the attached matrix.)

Section IA – 128.

Appendix J104.5 Slope failure reports.

This amendment is the same as in the 2008, 2011, 2014, 2017 and 2020 Glendale Building and Safety Code.

This amendment establishes minimum requirements for information that is to be included in slope failure reports, by adding additional requirements that are deficient in the 2019 California Building Code (CBC).

Slope failure report requirements will be based on the classification of the failure, as either a Class I, Class II or Class III slope failure as defined in Appendix J.

(Justification: Geologic, Climatic and Topographic - See justifications F, G and H in the attached matrix.)

Section IA – 129.

Appendix J104.6 Permit issuance.

This amendment is the same as in the 2008, 2011, 2014, 2017 and 2020 Glendale Building and Safety Code.

This amendment establishes various administrative standards related to the issuance of grading permits.

(Justification: Administrative - See justification E in the attached matrix.)

Section IA – 130.

Appendix J105.3 Field engineer.

This amendment is the same as in the 2008, 2011, 2014, 2017 and 2020 Glendale Building and Safety Code.

This amendment establishes the administrative responsibility of the field engineer for all grading projects. (Justification: Administrative - See justification E in the attached matrix.)

Section IA – 131.

Appendix J105.4 Geotechnical engineer.

This amendment is the same as in the 2008, 2011, 2014, 2017 and 2020 Glendale Building and Safety Code.

This amendment establishes the administrative responsibility of the soils engineer for all grading projects. (Justification: Administrative - See justification E in the attached matrix.)

Section IA – 132.

Appendix J105.5 Engineering geologist.

This amendment is the same as in the 2008, 2011, 2014, 2017 and 2020 Glendale Building and Safety Code.

This amendment establishes the administrative responsibility of the engineering geologist for all grading projects.

(Justification: Administrative - See justification E in the attached matrix.)

Section IA – 133.

Appendix J105.6 Permittee.

This amendment is the same as in the 2008, 2011, 2014, 2017 and 2020 Glendale Building and Safety Code.

This amendment establishes the administrative responsibility of the permittee for all grading projects. (Justification: Administrative - See justification E in the attached matrix.)

Section IA – 134.

Appendix J105.7 Building official.

This amendment is the same as in the 2008, 2011, 2014, 2017 and 2020 Glendale Building and Safety Code.

This amendment establishes the authority of the building official, and identifies various stages of grading inspection activity that are generally required for, and must be approved for, all grading projects.

(Justification: Administrative - See justification E in the attached matrix.)

Section IA – 135.

Appendix J105.8 Notification of noncompliance.

This amendment is the same as in the 2008, 2011, 2014, 2017 and 2020 Glendale Building and Safety Code.

This amendment establishes the administrative responsibility of the field engineer, the soils engineer and the engineering geologist in reporting any observation that work is not being performed in conformance with the approved grading plans.

(Justification: Administrative - See justification E in the attached matrix.)

Section IA – 136.

Appendix J105.9 Transfer of responsibility.

This amendment is the same as in the 2008, 2011, 2014, 2017 and 2020 Glendale Building and Safety Code.

This amendment establishes the permittee’s responsibility in identifying changes in responsibility when there is a change in the field engineer, the soils engineer or the engineering geologist.

(Justification: Administrative - See justification E in the attached matrix.)

Section IA – 137.

Appendix J105.10 Non-inspected grading

This amendment is the same as in the 2008, 2011, 2014, 2017 and 2020 Glendale Building and Safety Code.

This amendment expressly prohibits any person from owning, using, occupying or maintaining any grading which is not authorized by a grading permit and an approved grading plan.

(Justification: Administrative - See justification E in the attached matrix.)

Section IA – 138.

Appendix J105.11 Routine field inspections and reports.

This amendment is the same as in the 2008, 2011, 2014, 2017 and 2020 Glendale Building and Safety Code.

This amendment establishes various administrative standards pertaining to grading inspection reports.

(Justification: Administrative - See justification E in the attached matrix.)

Section IA – 139.

Appendix J105.12 Completion of work.

This amendment is the same as in the 2008, 2011, 2014, 2017 and 2020 Glendale Building and Safety Code.

This amendment establishes various administrative requirements related to final plans and technical reports that shall be submitted to the building official upon completion of all grading projects.

(Justification: Administrative - See justification E in the attached matrix.)

Section IA – 140.

Appendix J105.13 Notification of completion.

This amendment is the same as in the 2008, 2011, 2014, 2017 and 2020 Glendale Building and Safety Code.

This amendment establishes the administrative responsibility of the permittee to notify the building official of completion of grading operations.

(Justification: Administrative - See justification E in the attached matrix.)

Section IA – 141.

Appendix J105.14 Change of ownership.

This amendment is the same as in the 2008, 2011, 2014, 2017 and 2020 Glendale Building and Safety Code.

This amendment establishes the administrative responsibility of the property owner to secure a new grading permit when property ownership changes.

(Justification: Administrative - See justification E in the attached matrix.)

Section IA – 142.

Appendix J106.1 Maximum cut slope.

This amendment is the same as in the 2008, 2011, 2014, 2017 and 2020 Glendale Building and Safety Code.

This amendment establishes the maximum permissible slope for grading projects that involve cut slopes. (Justification: Geologic, Climatic and Topographic - See justifications F, G and H in the attached matrix.)

Section IA – 143.

Appendix J106.2 Drainage.

This amendment is the same as in the 2008, 2011, 2014, 2017 and 2020 Glendale Building and Safety Code.

This amendment establishes drainage parameters to ensure the proper disposal of excess storm water from a site.

(Justification: Climatic and Topographic - See justifications G and H in the attached matrix.)

Section IA – 144.

Appendix J107.1 General.

This amendment is the same as in the 2008, 2011, 2014, 2017 and 2020 Glendale Building and Safety Code.

This amendment establishes general provisions applicable to the placement of fill material on a site.

(Justification: Geologic, Climatic and Topographic - See justifications F, G and H in the attached matrix.)

Section IA – 145.

Appendix J107.2 Surface preparation.

This amendment is the same as in the 2008, 2011, 2014, 2017 and 2020 Glendale Building and Safety Code.

This amendment establishes specific requirements pertaining to the proper surface preparation of a site prior to the placement of fill material.

(Justification: Geologic, Climatic and Topographic - See justifications F, G and H in the attached matrix.)

Section IA – 146.

Appendix J107.3 Benching.

This amendment is the same as in the 2008, 2011, 2014, 2017 and 2020 Glendale Building and Safety Code.

This amendment establishes general provisions applicable to the construction of bench cuts within the supporting surface beneath certain fill slopes to increase stability.

(Justification: Geologic, Climatic and Topographic - See justifications F, G and H in the attached matrix.)

Section IA – 147.

Appendix J107.6 Maximum slope.

This amendment is the same as in the 2008, 2011, 2014, 2017 and 2020 Glendale Building and Safety Code.

This amendment establishes the maximum permissible slope for grading projects that involve fill slopes.

(Justification: Geologic, Climatic and Topographic - See justifications F, G and H in the attached matrix.)

Section IA – 148.

Appendix J107.7 Slopes to receive fill.

This amendment is the same as in the 2008, 2011, 2014, 2017 and 2020 Glendale Building and Safety Code.

This amendment establishes a minimum setback for certain fill slopes from the top edge of a slope, when such fill is placed above an existing slope.

(Justification: Geologic, Climatic and Topographic – See justifications F, G and H in the attached matrix.)

Section IA – 149.

Appendix J107.8 Inspection of fill

This amendment is the same as in the 2008, 2011, 2014, 2017 and 2020 Glendale Building and Safety Code.

This amendment establishes minimum inspection and observation responsibilities for the soils engineer during the placement of fill material.

(Justification: Geologic, Climatic and Topographic - See justifications F, G and H in the attached matrix.)

Section IA – 150.

Appendix J107.9 Testing of fills.

This amendment is the same as in the 2008, 2011, 2014, 2017 and 2020 Glendale Building and Safety Code.

This amendment establishes minimum soil testing requirements for grading activities that involve the placement of fill material.

(Justification: Geologic, Climatic and Topographic - See justifications F, G and H in the attached matrix.)

Section IA – 151.

Appendix J108 SETBACKS AND RETAINING WALLS.

This amendment is the same as in the 2008, 2011, 2014, 2017 and 2020 Glendale Building and Safety Code.

This amendment establishes standards related to setbacks for graded slopes and retaining walls relative to both the top and/or toe of a graded slope in relationship to property lines or structures. This amendment also establishes specific requirements that are applicable to the design, construction and inspection of retaining walls and crib walls that are intended to retain earth material. Additionally, this amendment authorizes the building official to approve an alternate setback dimension from a graded slope and authorizes the building official to require an investigation and recommendation from a qualified soils engineer or engineering geologist.

(Justification: Geologic, Climatic and Topographic - See justifications F, G and H in the attached matrix.)

Section IA – 152.

Appendix J109.1 General.

This amendment is the same as in the 2008, 2011, 2014, 2017 and 2020 Glendale Building and Safety Code.

This amendment establishes general requirements pertaining to drainage facilities associated with sites which will involve grading activities.

(Justification: Geologic, Climatic and Topographic - See justifications F, G and H in the attached matrix.)

Section IA – 153.

Appendix J109.3 Interceptor drains and overflow protection.

This amendment is the same as in the 2008, 2011, 2014, 2017 and 2020 Glendale Building and Safety Code.

This amendment establishes drainage requirements that are specifically associated with interceptor drains and overflow protection.

(Justification: Geologic, Climatic and Topographic - See justifications F, G and H in the attached matrix.)

Section IA – 154.

Appendix J109.5 Disposal.

This amendment is the same as in the 2008, 2011, 2014, 2017 and 2020 Glendale Building and Safety Code.

This amendment establishes specific requirements to regulate the disposal of concentrated storm water that is collected by drainage facilities that are constructed as part of an approved grading plan.

(Justification: Geologic, Climatic and Topographic – See justifications F, G and H in the attached matrix.)

Section IA – 155.

Appendix J110.1 General.

This amendment is the same as in the 2008, 2011, 2014, 2017 and 2020 Glendale Building and Safety Code.

This amendment establishes general requirements to control erosion of graded slopes.

(Justification: Geologic, Climatic and Topographic - See justifications F, G and H in the attached matrix.)

Section IA – 156.

Appendix J111 REFERENCED STANDARDS.

This amendment is the same as in the 2008, 2011, 2014, 2017 and 2020 Glendale Building and Safety Code.

This amendment identifies referenced standards that are applicable to the proper design, construction and inspection of grading projects.

(Justification: Administrative - See justification E in the attached matrix.)

Section IA – 157.

Appendix J112 NATIONAL POLLUTANT DISCHARGE ELIMINATION SYSTEM (NPDES) COMPLIANCE.

This amendment is the same as in the 2014, 2017 and 2020 Glendale Building and Safety Code, renumbered from Section J113 to match the new code format.

This amendment establishes minimum standards that apply to all grading and construction related projects to comply with statutorily mandated requirements associated with the National Pollutant Discharge Elimination System (NPDES).

(Justification: Geologic, Climatic and Topographic - See justifications F, G and H in the attached matrix.)

Volume IB
Residential Standards

Section 1B – 2.

Chapter 1 Division II, Section R104.10.2 Fire code official concurrence.

This amendment is the same as in the 2011, 2014, 2017 and 2020 Glendale Building and Safety Code. This amendment provides administrative clarification regarding the need for concurrence by the Fire code official on appeals/slight code modifications which involve fire/life safety issues.
(Justification: Administrative - See justification A in the attached matrix)

Section IB – 3.

Chapter 1 Division II, Section R104.11.2 Fire code official concurrence.

This amendment is the same as in the 2011, 2014, 2017 and 2020 Glendale Building and Safety Code. This amendment provides administrative clarification regarding the need for concurrence by the Fire code official on the use of alternate materials or methods of construction which involve fire/life safety issues.
(Justification: Administrative - See justification A in the attached matrix)

Section IB – 4.

Chapter 1 Division II, Section R105.3 Application for permit.

This amendment is the same as in the 2011, 2014, 2017 and 2020 Glendale Building and Safety Code. This amendment establishes the requirement for a plan review fee to be paid.
(Justification: Administrative - See justification A in the attached matrix)

Section IB - 5.

Chapter 1 Division II, Section R105.3.1.1 Determination of substantially improved or substantially damaged existing buildings in flood hazard areas.

This amendment is the same as in the 2011, 2014, 2017 and 2020 Glendale Building and Safety Code. This amendment is necessary to be consistent with building code language.
(Justification: Administrative - See justification A in the attached matrix)

Section IB - 6.

Chapter 1 Division II, Section R105.3.1.2 Small residential rooftop solar energy system review process.

This amendment is the same as in the 2017 and 2020 Glendale Building and Safety Code. This amendment is necessary to be consistent with the State's Assembly Bill 2188 and to establish administrative regulations and provide an expedited, streamlined review process for the permitting and installation of small rooftop solar energy systems as adopted by Ordinance 5937.
(Justification: Administrative, Geologic, Climatic, Topographic - See justification A, B, C, and D in the attached matrix.)

Section IB – 7.

Chapter 1 Division II, Section R105.3.2 Time limitation of application.

This amendment is the same as in the 2011, 2014, 2017 and 2020 Glendale Building and Safety Code. This amendment establishes a time limit for plan review to match legislation passed by City Council in 2005.
(Justification: Administrative – See justification A in the attached matrix)

Section IB – 8.

Chapter 1 Division II, Section R105.3.3 Plan review fees.

This amendment is the same as in the 2011, 2014, 2017 and 2020 Glendale Building and Safety Code. This amendment provides for the establishment of fees by resolution of the City Council.

(Justification: Administrative - See justification A in the attached matrix)

Section IB – 9.

Chapter 1 Division II, Section R105.5 Expiration.

This amendment is the same as in the 2011, 2014, 2017 and 2020 Glendale Building and Safety Code.

This amendment provides a time limit for plan review to match legislation passed by city Council in 2005 and establishes the procedures for renewing action on an expired application.

(Justification: Administrative - See justification A in the attached matrix)

Section IB- 10.

Chapter 1 Division II, Section R105.8 Responsibility of permittee.

This amendment is the same as in the 2011, 2014, 2017 and 2020 Glendale Building and Safety Code.

This amendment clearly establishes the permit applicant's responsibilities in express fashion, rather than reliance upon implicit understanding of same.

(Justification: Administrative - See justification A in the attached matrix)

Section IB - 11.

Chapter 1 Division II, Section R106.3.4 Deferred submittals.

This amendment is the same as in the 2011, 2014, 2017 and 2020 Glendale Building and Safety Code.

This amendment makes the Residential Standards in Volume IB of the 2017 Glendale Building and Safety Code consistent with the Building Standards in Volume IA of the 2017 Glendale Building and Safety Code. This amendment provides portions of design work to be deferred and submitted within a specified period.

(Justification: Administrative - See justification A in the attached matrix)

Section IB - 12.

Chapter 1 Division II, Section R108.6 Work commencing before permit issuance.

This amendment is the same as in the 2011, 2014, 2017 and 2020 Glendale Building and Safety Code.

This amendment establishes the fees to be collected when a permit is issued for which the work has commenced before obtaining the permit.

(Justification: Administrative - See justification A in the attached matrix)

Section IB – 13.

Chapter 1 Division II, Section R109.1.5.4 Structural observation.

This amendment is the same as in the 2011, 2014, 2017 and 2020 Glendale Building and Safety Code.

This amendment refers to administrative procedures to be followed when structural observation is required.

(Justification: Administrative - See justification A in the attached matrix)

Section IB – 14.

Chapter 1 Division II, Section R109.1.5.4 Sound transmission control.

This amendment is the same as in the 2011, 2014, 2017 and 2020 Glendale Building and Safety Code.

This amendment refers to administrative procedures to be followed when inspecting lath and gypsum board.

(Justification: Administrative - See justification A in the attached matrix)

Section IB – 15.

Chapter 1 Division II, Section R109.5 Reinspections.

This amendment is the same as in the 2017 and 2020 Glendale Building and Safety Code.

This amendment restores and re-introduces a previous requirement in the building code that allows the Building Official to assess re-inspection fees in cases such as when inspection is called and work is not complete or when corrections called for are not made. This amendment makes the Residential Standards in Volume IB of the 2020 Glendale Building and Safety Code consistent with the Building Standards in Volume IA, Plumbing Standards in Volume II, Mechanical Standards in Volume III, and Electrical Standards in Volume IV of the 2020 Glendale Building and Safety Code.

(Justification: Administrative - See justification A in the attached matrix)

Section IB – 16.

Chapter 1 Division II, Section R112 BUILDING AND FIRE BOARD OF APPEALS.

This amendment is the same as in the 2011, 2014, 2017 and 2020 Glendale Building and Safety Code.

This amendment establishes the joint Building and Fire Board of Appeals and the administrative procedures for the board.

(Justification: Administrative - See justification A in the attached matrix)

Section IB – 17.

Chapter 1 Division II, Section R113.1 Unlawful acts.

This amendment is the same as in the 2011, 2014, 2017 and 2020 Glendale Building and Safety Code.

This amendment re-introduces administrative procedures when working with unsafe buildings and structures.

(Justification: Administrative - See justification A in the attached matrix)

Section IB – 18.

Chapter 1 Division II, Section R113.4 Violation penalties.

This amendment is the same as in the 2011, 2014, 2017 and 2020 Glendale Building and Safety Code.

This amendment re-introduces administrative procedures when working with unsafe buildings and structures. This amendment is necessary to clarify administrative enforcement procedures, and establishes penalties

(Justification: Administrative - See justification A in the attached matrix)

Section IB – 19.

Chapter 1 Division II, Section R114.1 Notice to owner or the owner's authorized agent.

This amendment is the same as in the 2011, 2014, 2017 and 2020 Glendale Building and Safety Code.

This amendment refers to administrative procedures to allow the building official to enforce local regulations.

(Justification: Administrative - See justification A in the attached matrix)

Section IB – 20.

Chapter 1 Division II, Section R114.2 Unlawful continuance.

This amendment is the same as in the 2011, 2014, 2017 and 2020 Glendale Building and Safety Code.

This amendment identifies violations as misdemeanors.

(Justification: Administrative - See justification A in the attached matrix)

Section IB - 21.

Chapter 1 Division II, Section R115 UNSAFE STRUCTURES AND EQUIPMENT.

This amendment is the same as in the 2011, 2014, 2017 and 2020 Glendale Building and Safety Code.

This amendment refers to administrative procedures to be followed when working with unsafe buildings or structures.

(Justification: Administrative - See justification A in the attached matrix)

Section IB – 22.

Chapter 1 Division II, Section R116 CONSTRUCTION TOILET FACILITIES.

This amendment is the same as in the 2011, 2014, 2017 and 2020 Glendale Building and Safety Code. This amendment requires construction sites to be equipped with available toilet facilities.

(Justification: Administrative - See justification A in the attached matrix)

Section IB – 23.

Chapter 1 Division II, Section R117 ON SITE CONSTRUCTION TRASH AND DEBRIS CONTROL.

This amendment is the same as in the 2011, 2014, 2017 and 2020 Glendale Building and Safety Code. This amendment requires trash and debris control for facilities for construction sites.

(Justification: Administrative - See justification A in the attached matrix)

Section IB – 24.

Chapter 1 Division II, Section R118 DISASTER REPAIR AND RECONSTRUCTION.

This amendment is the same as in the 2011, 2014, 2017 and 2020 Glendale Building and Safety Code. This amendment establishes administrative procedures related to the repair and reconstruction of structures affected by a disaster.

(Justification: Administrative - See justification A in the attached matrix)

Section IB - 25.

Chapter 1 Division II, Section R119 SANDBLASTING.

This amendment is the same as in the 2011, 2014, 2017 and 2020 Glendale Building and Safety Code. This amendment establishes administrative regulations regarding sandblasting activities to protect adjoining property from potential damage due to over spray.

(Justification: Administrative - See justification A in the attached matrix)

Section IB - 26.

Chapter 1 Division II, Section R120 PROTECTION OF PEDESTRIANS.

This amendment is the same as in the 2011, 2014, 2017 and 2020 Glendale Building and Safety Code. This amendment makes the Residential Standards in Volume IB of the 2020 Glendale Building and Safety Code consistent with the Building Standards in Volume IA of the 2020 Glendale Building and Safety Code. This amendment provides for the protection of pedestrians during construction.

(Justification: Administrative - See justification A in the attached matrix)

Section IB - 27.

R301.1.3.1 California licensed architect or engineer.

This amendment is the same as in the 2017 and 2020 Glendale Building and Safety Code.

This amendment require all construction documents submitted for permit shall be approved and stamped by a California licensed architect or engineer with the exception when the building official determines, based upon a review of the construction documents submitted, that the scope of work is minor in nature.

(Justification: Geologic and Topographic – See justification B and D in the attached matrix)

Section IB - 28.

R301.1.3.2 Woodframe structures.

This amendment is the same as in the 2017 and 2020 Glendale Building and Safety Code.

This amendment require all construction documents submitted for permit shall be approved and stamped by a California licensed architect or engineer with the exception when the building official determines, based upon a review of the construction documents submitted, that the scope of work is minor in nature.

(Justification: Geologic – See justification B in the attached matrix)

Section IB - 29.

R301.1.3.3 Structures other than woodframe.

This amendment is the same as in the 2017 and 2020 Glendale Building and Safety Code.

This amendment require all construction documents submitted for permit shall be approved and stamped by a California licensed architect or engineer with the exception when the building official determines, based upon a review of the construction documents submitted, that the scope of work is minor in nature. (Justification: Geologic – See justification B in the attached matrix)

Section IB - 30.

R301.1.5 Seismic design provisions for buildings constructed on or into slopes steeper than one unit vertical in three units horizontal (33.3 percent slope).

This amendment is the same as in the 2011, 2014, 2017 and 2020 Glendale Building and Safety Code.

This amendment prohibits non-engineered wood frame construction on a steep slope greater than 3 to 1. (Justification: Geologic and Topographic – See justification B and D in the attached matrix)

Section IB - 31.

Table R301.2 CLIMATIC AND GEOGRAPHIC DESIGN CRITERIA.

This table is similar to the table in the 2014, 2017 and 2020 Glendale Building and Safety Code with some updates.

This table establishes the design criteria for the application of the California Residential Code to the regional climatic and geographic conditions that exist in the City of Glendale.

(Justification: Administrative - See justification A in the attached matrix.)

Section IB - 32.

R301.2.2.2.6 Irregular buildings.

This amendment is the same as in the 2011, 2014, 2017 and 2020 Glendale Building and Safety Code, renumbered from Section R301.2.2.5 to match the new code format.

This amendment expands the definition of an irregular building by eliminating the exceptions.

(Justification: Geologic and Topographic – See justification B and D in the attached matrix)

Section IB - 33.

R301.2.2.11 Anchorage of mechanical, electrical, or plumbing components and equipment.

This amendment is the same as in the 2011, 2014, 2017 and 2020 Glendale Building and Safety Code, renumbered from Section R301.2.2.3.8 to match the new code format.

This amendment makes the Residential Standards in Volume IB of the 2020 Glendale Building and Safety Code consistent with the Building Standards in Volume IA of the 2020 Glendale Building and Safety Code.

This amendment limits the prescriptive equipment anchorage design weight to a maximum of 400 pounds and a maximum center of gravity height of 4 feet above the floor or attic level or when the equipment weight is 20 lbs maximum or when the distributed system weight is limited to 5 lbs/ft without engineered design. Requirements from ASCE 7 and the California Building Code would permit equipment weighing up to 400 lbs. with center of gravity height 4 feet or less above the floor or attic level or when the equipment weight is 20 lbs maximum or when the distributed system weight is limited to 5 lbs/ft without engineering design.

Where equipment exceeds these requirements, it is the intent of this proposed amendment that a registered design professional be required to analyze the equipment anchorage.

(Justification: Geologic – See justification B in the attached matrix)

Section IB – 34.

R302.1.1 Construction on contiguous lots under same ownership or occupancy.

This amendment is the same as in the 2011, 2014, 2017 and 2020 Glendale Building and Safety Code.

This amendment establishes construction requirements for structures constructed on two or more contiguous lots, when such lots are held under common ownership or occupancy.

(Justification: Administrative - See justification A in the attached matrix)

Section IB – 35.

R313 AUTOMATIC FIRE SPRINKLER SYSTEMS.

This amendment is the same as in the 2011, 2014, 2017 and 2020 Glendale Building and Safety Code. This amendment makes the Residential Standards in Volume IB of the 2020 Glendale Building and Safety Code consistent with the Building Standards in Volume IA of the 2020 Glendale Building and Safety Code.

(Justification: Geologic, Climatic, Topographic - See justification B, C, and D in the attached matrix.)

Section IB – 36.

R314.6 Power source.

This amendment is the same as in the 2011, 2014, 2017 and 2020 Glendale Building and Safety Code. This amendment makes the Residential Standards in Volume IB of the 2020 Glendale Building and Safety Code consistent with the Building Standards in Volume IA of the 2020 Glendale Building and Safety Code.

(Justification: Administrative, Geologic, Climatic, Topographic - See justification A, B, C, and D in the attached matrix.)

Section IB – 37.

R319.1 Address numbers.

This amendment is the same as in the 2011, 2014, 2017 and 2020 Glendale Building and Safety Code. This amendment makes the Residential Standards in Volume IB of the 2023 Glendale Building and Safety Code consistent with the Building Standards in Volume IA of the 2023 Glendale Building and Safety Code.

(Justification: Administrative - See justification A in the attached matrix)

Section IB – 38.

R401.1 Application.

This amendment is the same as in the 2011, 2014, 2017 and 2020 Glendale Building and Safety Code. This amendment makes the Residential Standards in Volume IB of the 2023 Glendale Building and Safety Code consistent with the Building Standards in Volume IA of the 2023 Glendale Building and Safety Code. This amendment prohibits the use of wood foundations.

(Justification: Geologic and Climatic – See justification B and C in the attached matrix)

Section IB – 39.

R401.4 Soils test.

This amendment is the same as in the 2011, 2014, 2017 and 2020 Glendale Building and Safety Code. This amendment codifies conditions of approvals for a building code modification for small projects less than 500 square feet in size. This amendment will also help expedite Building and Safety's plan review process.

(Justification: Geologic – See justification B in the attached matrix)

Section IB – 40.

Section R401.5 Grading.

This amendment is the same as in the 2011, 2014, 2017 and 2020 Glendale Building and Safety Code. This amendment makes the Residential Standards in Volume IB of the 2020 Glendale Building and Safety Code consistent with the Building Standards in Volume IA of the 2020 Glendale Building and Safety Code.

(Justification: Administrative, Geologic, Climatic, and Topographic: – See justification E, F, G, and H in the attached matrix)

Section IB – 41.

R402.1 Wood Foundation.

This amendment is the same as in the 2011, 2014, 2017 and 2020 Glendale Building and Safety Code. This amendment makes the Residential Standards in Volume IB of the 2020 Glendale Building and Safety Code consistent with the Building Standards in Volume IA of the 2020 Glendale Building and Safety Code. Additionally, the local region is in an area with a very temperate climate, which is not subject to frequent ground freezing. As a combined result of constant moisture and soil which does not experience temperatures cold enough to destroy or retard the growth and proliferation of wood-destroying organisms, wood footings experience relatively rapid decay. This amendment will mitigate the detrimental affect of such organisms by prohibiting the use of wood foundations.

(Justification: Climatic - See justification C in the attached matrix)

Section IB – 42.

R403.1.2 Continuous footing in Seismic Design Category D₀, D₁, and D₂.

This amendment is the same as in the 2011, 2014, 2017 and 2020 Glendale Building and Safety Code. This amendment requires all interior braced wall panels in buildings be supported on continuous footings.

(Justification: Geologic: – See justification B in the attached matrix)

Section IB – 43.

Figure R403.1(2) PERMANENT WOOD FOUNDATION BASEMENT WALL SECTION.

This amendment is the same as in the 2011, 2014, 2017 and 2020 Glendale Building and Safety Code. This amendment makes the Residential Standards in Volume IB of the 2020 Glendale Building and Safety Code consistent with the Building Standards in Volume IA of the 2020 Glendale Building and Safety Code. Additionally, the local region is in an area with a very temperate climate, which is not subject to frequent ground freezing. As a combined result of constant moisture and soil which does not experience temperatures cold enough to destroy or retard the growth and proliferation of wood-destroying organisms, wood footings experience relatively rapid decay. This amendment will mitigate the detrimental affect of such organisms by prohibiting the use of wood foundations.

(Justification: Climatic - See justification B and C in the attached matrix)

Section IB - 44.

Figure R403.1(3) PERMANENT WOOD FOUNDATION CRAWL SPACE SECTION.

This amendment is the same as in the 2011, 2014, 2017 and 2020 Glendale Building and Safety Code. This amendment makes the Residential Standards in Volume IB of the 2020 Glendale Building and Safety Code consistent with the Building Standards in Volume IA of the 2020 Glendale Building and Safety Code. Additionally, the local region is in an area with a very temperate climate, which is not subject to frequent ground freezing. As a combined result of constant moisture and soil which does not experience temperatures cold enough to destroy or retard the growth and proliferation of wood-destroying organisms, wood footings experience relatively rapid decay. This amendment will mitigate the detrimental affect of such organisms by prohibiting the use of wood foundations.

(Justification: Climatic - See justification Band C in the attached matrix)

Section IB – 45.

R403.1.3.6 Isolated concrete footings.

This amendment is the same as in the 2011, 2014, 2017 and 2020 Glendale Building and Safety Code. This amendment eliminates the section and prohibits the use of plain concrete footings without reinforcing.

(Justification: Geologic: – See justification B in the attached matrix)

Section IB - 46.

R403.1.5 Slope.

This amendment is the same as in the 2011, 2014, 2017 and 2020 Glendale Building and Safety Code. This amendment makes the Residential Standards in Volume IB of the 2020 Glendale Building and Safety Code consistent with the Building Standards in Volume IA of the 2020 Glendale Building and Safety Code.

This amendment clarifies additional reinforcing for stepped footing assigned to higher Seismic Design Category. With the higher seismic demand placed on buildings and structures in this region, precautionary steps are proposed to reduce or eliminate potential problems that may result for under reinforced footings located on sloped surfaces. Requiring minimum reinforcement for stepped footings is intended to address the problem of poor performance of plain or under-reinforced footings during a seismic event.

(Justification: Geologic: – See justification B in the attached matrix)

Section IB – 47.

R404.2 Wood foundation wall.

This amendment is the same as in the 2011, 2014, 2017 and 2020 Glendale Building and Safety Code. This amendment makes the Residential Standards in Volume IB of the 2020 Glendale Building and Safety Code consistent with the Building Standards in Volume IA of the 2020 Glendale Building and Safety Code. This amendment essentially prohibits the use of spread wood footings. Additionally, the local region is in an area with a very temperate climate, which is not subject to frequent ground freezing. As a combined result of constant moisture and soil which does not experience temperatures cold enough to destroy or retard the growth and proliferation of wood-destroying organisms, wood footings experience relatively rapid decay. This amendment will mitigate the detrimental affect of such organisms by prohibiting the use of wood foundations.

(Justification: Climatic - See justification B and C in the attached matrix)

Section IB – 48.

R501.1 Application.

This amendment is the same as in the 2011, 2014, 2017 and 2020 Glendale Building and Safety Code. This amendment makes the Residential Standards in Volume IB of the 2020 Glendale Building and Safety Code consistent with the Building Standards in Volume IA of the 2020 Glendale Building and Safety Code. There is no limitation for weight of mechanical and plumbing fixtures and equipment in the California Residential Code. It is the intent of this proposed amendment that a registered design professional be required to analyze if the floor/attic/structure support is adequate and structurally sound.

(Justification: Geologic: – See justification B in the attached matrix)

Section IB – 49.

R503.2.4 Openings in horizontal diaphragms.

This amendment is the same as in the 2011, 2014, 2017 and 2020 Glendale Building and Safety Code. This amendment establishes prescriptive requirements for openings greater than 4 feet without engineering.

(Justification: Geologic: – See justification B in the attached matrix)

Section IB – 50.

FIGURE R503.2.4 OPENINGS IN HORIZONTAL DIAPHRAGMS.

This amendment is the same as in the 2011, 2014, 2017 and 2020 Glendale Building and Safety Code. This amendment establishes prescriptive requirements for openings greater than 4 feet without engineering.

(Justification: Geologic: – See justification B in the attached matrix)

Section IB – 51.

R503.3 Particleboard.

This amendment is the same as in the 2011, 2014, 2017 and 2020 Glendale Building and Safety Code. This amendment makes the Residential Standards in Volume IB of the 2020 Glendale Building and Safety Code consistent with the Building Standards in Volume IA of the 2020 Glendale Building and Safety Code. This amendment prohibits the use of particle board diaphragms. This amendment is necessary because the severe lateral ground displacement that is frequently experienced throughout the local region results in very strong lateral forces on buildings. Investigations after the Northridge earthquake revealed that this material performed poorly as a lateral force-resisting element. (Justification: Geologic- see justification B in the attached matrix)

Section IB – 52.

TABLE R602.3(1) FASTENING SCHEDULE.

This amendment is the same as in the 2011, 2014, 2017 and 2020 Glendale Building and Safety Code. This amendment prohibits the use of staples as fasteners for wood structural panel walls to resist high seismic forces. (Justification: Geologic: – See justification B in the attached matrix)

Section IB – 53.

R602.3.2 Top plate.

This amendment is the same as in the 2011, 2014, 2017 and 2020 Glendale Building and Safety Code. This amendment eliminates the use of single top plate construction to maintain the structural integrity of the framing of shear wall systems for building and structures subject to high seismic loads. The performance of modern-day braced wall panel construction is directly related to an adequate load path extending from the roof diaphragm to the foundation system. A single top plate is likely to be over nailed due to the nailing requirements at a rafter, stud, top plate splice, and braced wall panel edge in a single location. In addition, notching on a single top plate for plumbing, ventilation and electrical wiring may reduce the load transfer capacity of the plate without proper detailing. Majority of buildings and structures designed and built per the California Residential Code with a single top plate may not need structural observation and special inspections. The potential construction mistakes mentioned above could not be caught and corrected by knowledgeable engineers and inspectors and could jeopardize structural performance of buildings and structures located in high seismic areas. (Justification: Geologic: – See justification B in the attached matrix)

Section IB – 54.

TABLE R602.3.2 SINGLE TOP PLATE SPLICE CONNECTION DETAILS.

This amendment is the same as in the 2017 and 2020 Glendale Building and Safety Code. This amendment eliminates the use of single top plate construction to maintain the structural integrity of the framing of shear wall systems for building and structures subject to high seismic loads. The performance of modern-day braced wall panel construction is directly related to an adequate load path extending from the roof diaphragm to the foundation system. A single top plate is likely to be over nailed due to the nailing requirements at a rafter, stud, top plate splice, and braced wall panel edge in a single location. In addition, notching on a single top plate for plumbing, ventilation and electrical wiring may reduce the load transfer capacity of the plate without proper detailing. Majority of buildings and structures designed and built per the California Residential Code with a single top plate may not need structural observation and special inspections. The potential construction mistakes mentioned above could not be caught and corrected by knowledgeable engineers and inspectors and could jeopardize structural performance of buildings and structures located in high seismic areas. (Justification: Geologic: – See justification B in the attached matrix)

Section IB – 55.

TABLE R602.3(2) ALTERNATE ATTACHMENTS TO TABLE R602.3(1).

This amendment is the same as in the 2011, 2014, 2017 and 2020 Glendale Building and Safety Code. This amendment prohibits the use of staples as fasteners for wood structural panel walls to resist high seismic forces.

(Justification: Geologic: – See justification B in the attached matrix)

Section IB – 56.

R602.10.2.3 Minimum number of braced wall panels.

This amendment is the same as in the 2014, 2017 and 2020 Glendale Building and Safety Code. This proposed amendment is consistent with an amendment adopted during previous code adoption cycles for the California Building Code. Plywood shear walls with high aspect ratio experienced many failures during the Northridge Earthquake. This amendment specifies a minimum braced wall length to meet an aspect ratio consistent with other sections of the Residential Code as to provide a uniform standard of construction for designers and buildings to follow. This is intended to improve the performance level of buildings and structures that are subject to the higher seismic demands and reduce and limit potential damages to property. This amendment reflects the recommendations by the Structural Engineers Association of Southern California (SEAOSC) and the Los Angeles City Joint Task Force that investigated the poor performance observed in 1994 Northridge Earthquake.

(Justification: Geologic: – See justification B in the attached matrix)

Section IB – 57.

TABLE R602.10.3(3) BRACING REQUIREMENTS BASED ON SEISMIC DESIGN CATEGORY.

This amendment is the same as in the 2014, 2017 and 2020 Glendale Building and Safety Code. This amendment is also consistent with an amendment adopted during previous code adoption cycles for the California Building Code.

Due to the high geologic activities in the Southern California area and the expected higher level of performance on buildings and structures, this amendment increases the length and limits the location where shear walls sheathed with lath, plaster or gypsum board are used in multi-level buildings. In addition, shear walls sheathed with other materials are prohibited in Seismic Design Category D₀, D₁ and D₂ to be consistent with the design limitation for similar shear walls found in the California Building Code. The poor performance of such shear walls in the 1994 Northridge Earthquake was investigated by the Structural Engineers Association of Southern California (SEAOSC) and the Los Angeles City Task Force and formed the basis for this proposed amendment. Considering that shear walls sheathed with lath, plaster or gypsum board are less ductile than steel moment frames or wood structural panel shear walls, the cities and county of the Los Angeles region has taken the necessary measures to limit the potential structural damage that may be caused by the use of such walls at the lower level of multi-level building that are subject to higher levels of seismic loads.

(Justification: Geologic: – See justification B in the attached matrix)

Section IB – 58.

TABLE R602.10.4 BRACING METHODS.

This amendment is the same as in the 2014, 2017 and 2020 Glendale Building and Safety Code. This amendment is also consistent with an amendment adopted during previous code adoption cycles for the California Building Code.

3/8" thick 3 ply-plywood shear walls experienced many failures during the Northridge Earthquake. Box nails were observed to cause massive and multiple failures of the typical 3/8" thick 3-ply plywood during the Northridge Earthquake. This amendment specifies minimum sheathing thickness, nail size and spacing so as to provide a uniform standard of construction for designers and buildings to follow. This is intended to improve the performance level of buildings and structures that are subject to the higher seismic demands and reduce and limit potential damages to property. This proposed amendment reflects

the recommendations by the Structural Engineers Association of Southern California (SEAOSC) and the Los Angeles City Joint Task Force that investigated the poor performance observed in 1994 Northridge Earthquake.

In September 2007, limited cyclic testing was conducted by a private engineering firm to determine if wood structural panels fastened with staples would exhibit the same behavior as the wood structural panels fastened with common nails. The test result revealed that wood structural panel fastened with staples appeared to be much lower in strength and stiffness than wood structural panels fastened with common nails. It was recommended that the use of staples as fasteners for wood structural panel shear walls or diaphragms not be permitted to resist seismic forces in structures assigned to Seismic Design Category D₀, D₁ and D₂ unless it can be substantiated by cyclic testing.

(Justification: Geologic: – See justification B in the attached matrix)

Section IB – 59.

TABLE R602.10.5 MINIMUM LENGTH OF BRACE WALL PANELS.

This amendment is the same as in the 2014, 2017 and 2020 Glendale Building and Safety Code.

This amendment is also consistent with an amendment adopted during previous code adoption cycles for the California Building Code.

3/8” thick 3 ply-plywood shear walls experienced many failures during the Northridge Earthquake. Box nails were observed to cause massive and multiple failures of the typical 3/8” thick 3-ply plywood during the Northridge Earthquake. High aspect ratio shear walls experienced many failures during the Northridge Earthquake. This proposed amendment specifies minimum sheathing thickness, nail size and spacing so as to provide a uniform standard of construction for designers and buildings to follow. This is intended to improve the performance level of buildings and structures that are subject to the higher seismic demands and reduce and limit potential damages to property. This proposed amendment reflects the recommendations by the Structural Engineers Association of Southern California (SEAOSC) and the Los Angeles City Joint Task Force that investigated the poor performance observed in 1994 Northridge Earthquake.

(Justification: Geologic: – See justification B in the attached matrix)

Section IB – 60.

FIGURE R602.10.6.1 METHOD ABW-ALTERNATE BRACED WALL PANEL.

This amendment is the same as in the 2014, 2017 and 2020 Glendale Building and Safety Code.

3/8” thick 3 ply-plywood shear walls experienced many failures during the Northridge Earthquake. Box nails were observed to cause massive and multiple failures of the typical 3/8” thick 3-ply plywood during the Northridge Earthquake. This proposed amendment specifies minimum sheathing thickness, nail size and spacing so as to provide a uniform standard of construction for designers and buildings to follow. This is intended to improve the performance level of buildings and structures that are subject to the higher seismic demands and reduce and limit potential damages to property. This proposed amendment reflects the recommendations by the Structural Engineers Association of Southern California (SEAOSC) and the Los Angeles City Joint Task Force that investigated the poor performance observed in 1994 Northridge Earthquake.

(Justification: Geologic: – See justification B in the attached matrix)

Section IB – 61.

FIGURE R602.10.6.2 METHOD PFH: PORTAL FRAME WITH HOLD-DOWNS.

This amendment is the same as in the 2014, 2017 and 2020 Glendale Building and Safety Code.

3/8” thick 3 ply-plywood shear walls experienced many failures during the Northridge Earthquake. Box nails were observed to cause massive and multiple failures of the typical 3/8” thick 3-ply plywood during the Northridge Earthquake. This proposed amendment specifies minimum sheathing thickness, nail size and spacing so as to provide a uniform standard of construction for designers and buildings to follow. This is intended to improve the performance level of buildings and structures that are subject to the higher seismic demands and reduce and limit potential damages to property. This proposed amendment reflects

the recommendations by the Structural Engineers Association of Southern California (SEAOSC) and the Los Angeles City Joint Task Force that investigated the poor performance observed in 1994 Northridge Earthquake.

(Justification: Geologic: – See justification B in the attached matrix)

Section IB – 62.

FIGURE R602.10.6.4 METHOD CS-PF – CONTINUOUSLY SHEATHED PORTAL FRAME PANEL CONSTRUCTION.

This amendment is the same as in the 2014, 2017 and 2020 Glendale Building and Safety Code. 3/8” thick 3 ply-plywood shear walls experienced many failures during the Northridge Earthquake. Box nails were observed to cause massive and multiple failures of the typical 3/8” thick 3-ply plywood during the Northridge Earthquake. This proposed amendment specifies minimum sheathing thickness, nail size and spacing so as to provide a uniform standard of construction for designers and buildings to follow. This is intended to improve the performance level of buildings and structures that are subject to the higher seismic demands and reduce and limit potential damages to property. This proposed amendment reflects the recommendations by the Structural Engineers Association of Southern California (SEAOSC) and the Los Angeles City Joint Task Force that investigated the poor performance observed in 1994 Northridge Earthquake.

(Justification: Geologic: – See justification B in the attached matrix)

Section IB – 63.

R606.4.4 Parapet walls.

This amendment is the same as in the 2011, 2014, 2017 and 2020 Glendale Building and Safety Code. This amendment clarifies the requirement by adding the word “or”. This addition will prevent the use of unreinforced parapets in Seismic Design Category D₀, D₁ or D₂.

(Justification: Geologic: – See justification B in the attached matrix)

Section IB – 64.

R606.12.2.2.3 Reinforcement of requirements for masonry elements.

This amendment is the same as in the 2014, 2017 and 2020 Glendale Building and Safety Code. Reinforcement using longitudinal wires for buildings and structures located in high seismic areas are deficient and not as ductile as deformed rebar. Having vertical reinforcement closer to the ends of masonry walls help to improve the seismic performance of masonry buildings and structures.

(Justification: Geologic: – See justification B in the attached matrix)

Section IB – 65.

R803.2.4 Openings in horizontal diaphragms.

This amendment is the same as in the 2011, 2014, 2017 and 2020 Glendale Building and Safety Code. This amendment provides a reference to Section R503.2.4 for the prescriptive requirements for openings greater than 4 feet. Section R802 of the Code does not provide any prescriptive criteria to limit the maximum roof opening size nor does Section R803 provide any details to address the issue of shear transfer near larger roof openings. With the higher seismic demand placed on buildings and structures in this region, it is important to ensure that a complete load path is provided to reduce or eliminate potential damages caused by seismic forces. Requiring blocking with metal ties around larger roof openings and limiting opening size is consistent with the requirements of Section R301.2.2.2.5.

(Justification: Geologic: – See justification B in the attached matrix)

Section IB – 66.

902.1 Roofing covering materials.

This amendment is the same as in the 2011, 2014, 2017 and 2020 Glendale Building and Safety Code. This amendment eliminates the acceptance of Class C roofing materials. (Justification: Topographic and Climatic– see justification C and D in the attached matrix)

Section IB – 67.

R902.1.3 Roof coverings within all other areas.

This amendment is the same as in the 2011, 2014, 2017 and 2020 Glendale Building and Safety Code. This amendment prohibits the use of wood roof covering material and requires other roof coverings to have a Class A rating, or be made of materials meeting the requirements of a Class B roofing assembly in non-high fire hazard areas. (Justification: Topographic and Climatic– See justification C and D in the attached matrix)

Section IB – 68.

R902.4 Rooftop-mounted photovoltaic panels and modules.

This amendment is the same as in the 2017 and 2020 Glendale Building and Safety Code. This amendment is consistent with Volume IA of the 2023 Glendale Building and Safety Code to eliminate the acceptance of Class C roofing assembly. (Justification: Administrative, Geologic and Climatic- See justification A, B and C attached matrix)

Section IB – 69.

R905.3.7 Application.

This amendment is the same as in the 2011, 2014, 2017 and 2020 Glendale Building and Safety Code. This amendment changes the minimum number of fasteners for tile roofing material from one fastener to two fasteners per tile even on relatively flat roofs and increases the minimum side lap requirement for roofing felt. This amendment specifies nailing edge distances to ensure a sturdy connection. This amendment also establishes corrosion resistance characteristics for nails to mitigate water intrusion and water-accelerated corrosion of fastening material which results from heavy rains which occur throughout the local region. (Justification: Geologic and Climatic- See justification A attached matrix)

Section IB – 70.

TABLE R905.3.7 CLAY AND CONCRETE TILE ATTACHEMENT.

This amendment is the same as in the 2011, 2014, 2017 and 2020 Glendale Building and Safety Code. This amendment changes the minimum number of fasteners for tile roofing material from one fastener to two fasteners per tile even on relatively flat roofs and increases the minimum side lap requirement for roofing felt. This amendment specifies nailing edge distances to ensure a sturdy connection. This amendment also establishes corrosion resistance characteristics for nails to mitigate water intrusion and water-accelerated corrosion of fastening material which results from heavy rains which occur throughout the local region. (Justification: Geologic and Climatic- See justification A attached matrix)

Section IB – 71.

R908.7 Roof sheathing.

This amendment is the same as in the 2011, 2014, 2017 and 2020 Glendale Building and Safety Code. This amendment requires existing buildings to be provided with a plywood diaphragm when roofing material is stripped from the structure, if such buildings do not have such a diaphragm, (Justification: Geologic and Topographic– see justification B and D in the attached matrix)

Section IB – 72.

R918.1.7 Structural fire-resistance.

This amendment is the same as in the 2017 and 2020 Glendale Building and Safety Code.

This amendment incorporates the State Fire Marshalls for installation of solar photovoltaic power systems along with local amendments. This amendment is necessary to provide adequate protection from personal injury and property protection due to specific local conditions.

(Justification: Administrative, Topographic and Climatic - See justifications A, B and C in the attached matrix)

Section IB – 73.

R1001.3.1 Vertical reinforcing.

This amendment is the same as in the 2011, 2014, 2017 and 2020 Glendale Building and Safety Code to address structural deficiencies in the base codes.

This amendment establishes fireplace/chimney be adequately anchored into the concrete foundation. The performance of fireplace/chimney without anchorage to the foundation has been observed to be inadequate during major earthquakes. The lack of anchorage to the foundation can result in the overturning or displacement of the fireplace/chimney.

(Justification: Geologic: – See justification B in the attached matrix)

Section IB – 74.

Appendix AH. PATIO COVERS.

This amendment is the same as in the 2011, 2014, 2017 and 2020 Glendale Building and Safety Code.

This amendment adopts appendix Chapter AH which permits patio covers meeting the requirements of the appendix section to be designed for different loads than the residence to which it is accessory.

(Justification: Administrative- see justification A in the attached matrix)

Section IA – 75.

Appendix AH105.1 Design loads.

This amendment is the same as in the 2017 and 2020 Glendale Building and Safety Code.

This amendment prohibits the installation of any solar energy systems on patio covers designed by this section. This amendment is consistent Volume 1A of the 2020 Glendale Building and Safety Code.

(Justification: Geologic and Topographic – See justification B and D in the attached matrix)

Section IB – 76.

Appendix Chapter A1 SEISMIC STRENGTHENING PROVISIONS FOR UNREINFORCED MASONRY BEARING WALL BUILDINGS.

This amendment is the same as in the 2011, 2014, 2017 and 2020 Glendale Building and Safety Code.

This amendment clarifies the adoption of the Appendix Chapter A1 of the Existing Building Code as part of Volume IB of the 2020 Glendale Building and Safety Code.

(Justification: Geologic and Topographic– See justification B and D in the attached matrix)

Volume IC
Existing Building Standards

Section 1C – 2.

Chapter 1 Division II, Section 104.10.2 Fire code official concurrence.

This amendment is the same as in the 2017 and 2020 Glendale Building and Safety Code. This amendment provides administrative clarification regarding the need for concurrence by the Fire code official on appeals/slight code modifications which involve fire/life safety issues.
(Justification: Administrative - See justification A in the attached matrix)

Section IC – 3.

Chapter 1 Division II, Section 104.11.3 Fire code official concurrence.

This amendment is the same as in the 2017 and 2020 Glendale Building and Safety Code. This amendment provides administrative clarification regarding the need for concurrence by the Fire code official on the use of alternate materials or methods of construction which involve fire/life safety issues.
(Justification: Administrative - See justification A in the attached matrix)

Section IC – 4.

Chapter 1 Division II, Section 105.1 Permit Required.

This amendment is the same as in the 2017 and 2020 Glendale Building and Safety Code. This amendment maintains a requirement for a permit to stripe parking lots. (Justification: Administrative - see justification A in the attached matrix)

Section IC – 5.

Chapter 1 Division II, Section 105.3 Application for permit.

This amendment is the same as in the 2017 and 2020 Glendale Building and Safety Code. This amendment establishes the requirement for a plan review fee to be paid.
(Justification: Administrative - See justification A in the attached matrix)

Section IC – 6.

Chapter 1 Division II, Section 105.3.2 Time limitation of application.

This amendment is the same as in the 2017 and 2020 Glendale Building and Safety Code. This amendment establishes a time limit for plan review to match legislation passed by City Council in 2005.
(Justification: Administrative - See justification A in the attached matrix)

Section IC – 7.

Chapter 1 Division II, Section 105.3.3 Plan review fees.

This amendment is the same as in the 2017 and 2020 Glendale Building and Safety Code
This amendment provides for the establishment of fees by resolution of the City Council.
(Justification: Administrative - See justification A in the attached matrix)

Section IC – 8.

Chapter 1 Division II, Section 105.5 Expiration.

This amendment is the same as in the 2017 and 2020 Glendale Building and Safety Code. This amendment provides a time limit for plan review to match legislation passed by city Council in 2005 and establishes the procedures for renewing action on an expired application.
(Justification: Administrative - See justification A in the attached matrix)

Section IC- 9.

Chapter 1 Division II, Section 105.8 Responsibility of permittee.

This amendment is the same as in the 2017 and 2020 Glendale Building and Safety Code. This amendment clearly establishes the permit applicant's responsibilities in express fashion, rather than reliance upon implicit understanding of same.

(Justification: Administrative - See justification A in the attached matrix)

Section IC- 10.

Chapter 1 Division II, Section 106.6 Design professional in responsible charge.

This amendment is the same as in the 2017 and 2020 Glendale Building and Safety Code.

This amendment clearly establishes that all construction documents submitted for review shall be prepared by a registered design professional. This amendment also allows the building official to make a determination to waive the requirement after reviewing the submitted documents and establishes the work is minor in nature.

(Justification: Administrative - See justification A in the attached matrix)

Section IC – 11.

Chapter 1 Division II, Section 108.4 Work commencing before permit issuance.

This amendment is the same as in the 2017 and 2020 Glendale Building and Safety Code. This amendment establishes the fees to be collected when a permit is issued for which the work has commenced before obtaining the permit.

(Justification: Administrative - See justification A in the attached matrix)

Section IC – 12.

Chapter 1 Division II, Section 109.3.5 Lath and gypsum board inspection.

This amendment is the same as in the 2017 and 2020 Glendale Building and Safety Code. This amendment refers to administrative procedures to be followed when inspecting lath and gypsum board.

(Justification: Administrative - See justification A in the attached matrix)

Section IC – 13.

Chapter 1 Division II, Section 109.3.8.1 Structural observation.

This amendment is the same as in the 2017 and 2020 Glendale Building and Safety Code. This amendment refers to administrative procedures to be followed when structural observation is required.

(Justification: Administrative - see justification A in the attached matrix)

Section IC – 14.

Chapter 1 Division II, Section R109.7 Reinspections.

This amendment is the same as in the 2017 and 2020 Glendale Building and Safety Code. This amendment allows the Building Official to assess re-inspection fees in cases such as when inspection is called and work is not complete or when corrections called for are not made. This amendment makes the Building Standards in Volume IC of the 2020 Glendale Building and Safety Code consistent with the Building Standards in Volume IA, Residential Standards in Volume IB, Plumbing Standards in Volume II, Mechanical Standards in Volume III, and Electrical Standards in Volume IV of the 2020 Glendale Building and Safety Code.

Justification: Administrative - See justification A in the attached matrix)

Section IC – 15.

Chapter 1 Division II, Section 112 BUILDING AND FIRE BOARD OF APPEALS.

This amendment is the same as in the 2020 Glendale Building and Safety Code. This amendment establishes the joint Building and Fire Board of Appeals and the administrative procedures for the board.

(Justification: Administrative - See justification A in the attached matrix)

Section IC – 16.

Chapter 1 Division II, Section 113.1 Unlawful acts.

This amendment is the same as in the 2017 and 2020 Glendale Building and Safety Code. This amendment re-introduces administrative procedures when working with unsafe buildings and structures. (Justification: Administrative - See justification A in the attached matrix)

Section IC – 17.

Chapter 1 Division II, Section 113.4 Violation penalties.

This amendment is the same as in the 2017 and 2020 Glendale Building and Safety Code. This amendment re-introduces administrative procedures when working with unsafe buildings and structures. This amendment is necessary to clarify administrative enforcement procedures, and establishes penalties. (Justification: Administrative - See justification A in the attached matrix)

Section IC – 18.

Chapter 1 Division II, Section 114.1 Authority.

This amendment is the same as in the 2017 and 2020 Glendale Building and Safety Code. This amendment refers to administrative procedures to allow the building official to enforce local regulations. (Justification: Administrative - See justification A in the attached matrix)

Section IC – 19.

Chapter 1 Division II, Section 114.3 Unlawful continuance.

This amendment is the same as in the 2017 and 2020 Glendale Building and Safety Code. This amendment identifies violations as misdemeanors. (Justification: Administrative - see justification A in the attached matrix)

Section IC – 20.

Chapter 1 Division II, Section 115.6 Non-compliance.

This amendment is the same as in the 2017 and 2020 Glendale Building and Safety Code. This amendment refers to administrative procedures to be followed when working with unsafe buildings or structures. (Justification: Administrative - See justification A in the attached matrix)

Section IC – 21.

Chapter 1 Division II, Section 115.7 Vacated Buildings.

This amendment is the same as in the 2017 and 2020 Glendale Building and Safety Code. This amendment refers to administrative procedures to be followed when working with unsafe buildings or structures. (Justification: Administrative - See justification A in the attached matrix)

Section IC – 22.

Chapter 1 Division II, Section 118 CONSTRUCTION TOILET FACILITIES.

This amendment is the same as in the 2017 and 2020 Glendale Building and Safety Code. This amendment requires construction sites to be equipped with available toilet facilities. (Justification: Administrative - See justification A in the attached matrix)

Section IC – 23.

Chapter 1 Division II, Section 119 ON SITE CONSTRUCTION TRASH AND DEBRIS CONTROL.

This amendment is the same as in the 2017 and 2020 Glendale Building and Safety Code. This amendment requires trash and debris control for facilities for construction sites, (Justification: Administrative - See justification A in the attached matrix)

Section IC – 24.

Chapter 1 Division II, Section 120 DISASTER REPAIR AND RECONSTRUCTION.

This amendment is the same as in the 2017 and 2020 Glendale Building and Safety Code. This amendment establishes administrative procedures related to the repair and reconstruction of structures affected by a disaster.

(Justification: Administrative - See justification A in the attached matrix)

Section IC – 25.

Chapter 1 Division II, Section 121 SANDBLASTING.

This amendment is the same as in the 2017 and 2020 Glendale Building and Safety Code. This amendment establishes administrative regulations regarding sandblasting activities to protect adjoining property from potential damage due to over spray.

(Justification: Administrative - See justification A in the attached matrix)

Section IC – 26.

502.1 General.

This amendment is the same as in the 2017 and 2020 Glendale Building and Safety Code. This amendment determines when a building is being altered over 50% of its replacement value, the Building Official may require that all portions of the building be brought up to the standards of the current California Building Code or California Residential Code.

(Justification: Administrative- See justification A in the attached matrix)

Section IC – 27.

503.1 General.

This amendment is the same as in the 2017 and 2020 Glendale Building and Safety Code. This amendment determines when a building is being altered over 50% of its replacement value, the building official may require that all portions of the building be brought up to the standards of the current California Building Code or California Residential Code.

(Justification: Administrative- See justification A in the attached matrix)

Section IC – 28.

505.1 Replacement glass and windows.

This amendment is the same as in the 2017 and 2020 Glendale Building and Safety Code. This amendment keeps in place the standards that have been used in Building and Safety as we adopt the existing building code.

(Justification: Climatic, Topographic - See justification C, and D in the attached matrix.)

Section IC – 29.

1501.6.1 Walkways.

This amendment is the same as in the 2017 and 2020 Glendale Building and Safety Code. This amendment establishes administrative regulations regarding the construction of protective walkways adjacent to construction sites.

(Justification: Administrative See justification A in the attached matrix)

Section IC – 30.

1501.6.7.1 Shoring.

This amendment is the same as in the 2017 and 2020 Glendale Building and Safety Code. This amendment establishes administrative regulations regarding the construction of shoring to protect the public right-of-way.

(Justification: Administrative - See justification A in the attached matrix)

Section IC – 31.

1501.8 Protection of sidewalk excavations.

This amendment is the same as in the 2017 and 2020 Glendale Building and Safety Code. This amendment establishes administrative regulations regarding excavations within the public right-of-way or other public property.

(Justification: Administrative - See justification A in the attached matrix)

Section IC – 32.

1501.9 Protection of obstructions.

This amendment is the same as in the 2017 and 2020 Glendale Building and Safety Code. This amendment establishes administrative regulations regarding the placement of protective barriers to prevent accidents resulting from excavations or obstructions within the public right-of-way.

(Justification: Administrative - See justification A in the attached matrix)

Section IC – 33.

1503.4 Street Use Permits.

This amendment is the same as in the 2017 and 2020 Glendale Building and Safety Code. This amendment establishes administrative regulations regarding the use of the public right-of-way.

(Justification: Administrative - See justification A in the attached matrix)

Section IC – 34.

1503.5 Mixing mortar on public property.

This amendment is the same as in the 2017 and 2020 Glendale Building and Safety Code. This amendment establishes administrative regulations regarding the use of public property to mix mortar, concrete or similar material.

(Justification: Administrative - See justification A in the attached matrix)

Section IC – 35.

Appendix Chapter A1 SEISMIC STRENGTHENING PROVISIONS FOR UNREINFORCED MASONRY BEARING WALL BUILDINGS.

This amendment is the same as in the 2011, 2014, 2017 and 2020 Glendale Building and Safety Code. This amendment adopts to promote public welfare and safety by reducing the risk of death and injury from the effects of earthquake-induced damaged on existing unreinforced masonry wall buildings. These minimum standards for seismic strengthening will improve the seismic performance of these masonry buildings.

(Justification: Geologic and Topographic– See justification B and D in the attached matrix)

Section IC – 36.

Appendix Chapter A3 PRESCRIPTIVE PROVISIONS FOR SEIMIC STRENGTHENING OF CRIPPLE WALLS AND SILL PLATE ANCHORAGE OF LIGHT, WOOD-FRAME RESIDENTIAL BUILDINGS.

This amendment is the same as in the 2011, 2014, 2017 and 2020 Glendale Building and Safety Code. This amendment adopts to promote public welfare and safety by reducing the risk of earthquake-induced damaged to existing wood-frame, residential buildings. These prescriptive minimum standards will improve the seismic performance of these residential buildings.

(Justification: Geologic and Topographic– See justification B and D in the attached matrix)

Section IC – 37.

Appendix Chapter A4 EARTHQUAKE RISK REDUCTION IN WOOD-FRAME RESIDENTIAL BUILDINGS WITH SOFT, WEAK OR OPEN FRONT WALLS.

This amendment is the same as in the 2011, 2014, 2017 and 2020 Glendale Building and Safety Code. This amendment adopts to promote public welfare and safety by reducing the risk of death or injury as a result of the effect of earthquakes on existing wood-frame, multiple-unit residential buildings. The ground motion of past earthquakes has caused the loss of human life, personal injury and property damage in these types of buildings. Adopting Appendix A4 creates minimum standards to strengthen more vulnerable portion of these structures. These minimum standards will improve the performance of these buildings.

(Justification: Geologic and Topographic– See justification B and D in the attached matrix)

Section IC – 38.

Appendix Chapter A5 REFERENCE STANDARDS

This amendment is the same as in the 2011, 2014, 2017 and 2020 Glendale Building and Safety Code. This amendment adopts referenced standards that are referenced in various sections of Appendix A. This amendment clarifies the adoption of the Appendix Chapter A5 of the Existing Building Code as part of Volume IC of the 2020 Glendale Building and Safety Code.

(Justification: Administrative – See justification A in the attached matrix)

Volume II
Plumbing Standards

Section II – 2.

Chapter 1 Division II, 104.3.2 Plan Review Fees.

This amendment is the same as in the 1999, 2002, 2008, 2011, 2014, 2017 and 2020 Glendale Building and Safety Code.

This amendment provides for the establishment of fees by resolution of the City Council.

(Justification: Administrative- See justification A in the attached matrix)

Section II – 3.

Chapter 1 Division II, 104.5 Fees.

This amendment is the same as in the 1999, 2002, 2008, 2011, 2014, 2017 and 2020 Glendale Building and Safety Code.

This amendment provides for the establishment of fees by resolution of the City Council.

(Justification: Administrative- See justification A in the attached matrix)

Section II – 4.

Chapter 1 Division II, 105.2.6 Reinspections.

This amendment is the same as in the 2017 and 2020 Glendale Building and Safety Code.

This amendment makes the Plumbing Standards in Volume II of the 2020 Glendale Building and Safety Code consistent with the Building Standards in Volume IA, Residential Standards in Volume IB, Mechanical Standards in Volume III, and Electrical Standards in Volume IV of the 2020 Glendale Building and Safety Code.

(Justification: Administrative- See justification A in the attached matrix)

Section II – 5.

Chapter 1 Division II, 107 Building and Fire Board of Appeals.

This amendment is the same as in the 2002, 2008, 2011, 2014, 2017 and 2020 Glendale Building and Safety Code.

This amendment establishes administrative procedures regarding appeals.

(Justification: Administrative- See justification A in the attached matrix)

Section II – 6.

815 Water Softener Using Dry Wells for Discharge.

This amendment is the same as in the 1999, 2002, 2008, 2011, 2014, 2017 and 2020 Glendale Building and Safety Code.

This amendment restricts the use of water softener systems using dry wells for the discharge of effluents. Use of dry wells to dispose of effluents cannot be controlled in a manner which will prevent pollution of ground water.

(Justification: Geologic- See justification B in the attached matrix)

Volume III
Mechanical Standards

Section III – 2.

Chapter 1 Division II, 104.3.2 Plan Review Fees.

This amendment is essentially the same as in the 1999, 2002, 2008, 2011, 2014, 2017 and 2020 Glendale Building and Safety Code.

This amendment provides for the establishment of fees by resolution of the City Council.

(Justification: Administrative - See justification A in the attached matrix)

Section III – 3.

Chapter 1 Division II, 104.5 Fees.

This amendment is the same as in the 1999, 2002, 2008, 2011, 2014, 2017 and 2020 Glendale Building and Safety Code.

This amendment provides for the establishment of fees by resolution of the City Council.

(Justification: Administrative - See justification A in the attached matrix)

Section II – 4.

Chapter 1 Division II, 105.2.6 Reinspections.

This amendment is the same as in the 2017 and 2020 Glendale Building and Safety Code,

This amendment makes the Mechanical Standards in Volume III of the 2020 Glendale Building and Safety Code consistent with the Building Standards in Volume IA, Residential Standards in Volume IB, Plumbing Standards in Volume II and Electrical Standards in Volume IV of the 2020 Glendale Building and Safety Code.

(Justification: Administrative- See justification A in the attached matrix)

Section III – 5.

Chapter 1 Division II, 107.0 Building and Fire Board of Appeals.

This amendment is the same as in the 1999, 2002, 2008, 2011, 2014, 2017 and 2020 Glendale Building and Safety Code.

This amendment establishes the creation of the Building and Fire Board of Appeals.

(Justification: Administrative - See justification A in the attached matrix)

Volume IV
Electrical Standards

Section IV – 2.

90.10 Materials and equipment.

This amendment is the same as in the 2002, 2008, 2011, 2014, 2017 and 2020 Glendale Building and Safety Code. This amendment establishes administrative standards used to consider electrical materials and equipment as approved for use. Such administrative standards include determinations by the building official.

(Justification: Administrative - See justification A in the attached matrix)

Section IV – 3.

90.11 Revocation and approval for use.

This amendment is the same as in the 2002, 2008, 2011, 2014, 2017 and 2020 Glendale Building and Safety Code. This amendment establishes administrative standards regarding the revocation of approvals granted by the building official to use electrical materials and equipment.

(Justification: Administrative - See justification A in the attached matrix)

Section IV – 4.

90.12 Building and Fire Board of Appeals.

This amendment is the same as in the 2002, 2008, 2011, 2014, 2017 and 2020 Glendale Building and Safety Code. This amendment establishes the creation of the joint Building and Fire Board of Appeals.

(Justification: Administrative- see justification A in the attached matrix)

Section IV – 5.

Article 91 ENFORCEMENT.

This amendment is the same as in the 2002, 2008, 2011, 2014, 2017 and 2020 Glendale Building and Safety Code. This amendment establishes administrative procedures regarding the enforcement of electrical standards throughout the city.

(Justification: Administrative - See justification A in the attached matrix)

Section IV – 6.

Article 92 PERMITS AND FEES.

This amendment is the same as in the 2002, 2008, 2011, 2014, 2017 and 2020 Glendale Building and Safety Code. This amendment establishes administrative provisions regarding the determination and collection of fees for services, and the administration of permits and inspections and deleting the special annual permit for maintenance work. This amendment also deleted the special permit to owners for work in own residence which is already contained in the state license laws.

(Justification: Administrative - See justification A in the attached matrix)

Section IV – 7.

690.96 Solar Photovoltaic panels/modules.

This amendment is the same as in the 2011, 2014, 2017 and 2020 Glendale Building and Safety Code. This amendment establishes the requirements for the design and installation of photovoltaic panels/modules which is not provided in the base codes. This amendment is necessary to provide adequate protection from personal injury and property protection due to specific local conditions.

(Justification: Administrative, Topographic and Climatic - See justifications A, B and C in the attached matrix)

Volume V
Housing Standards

Section V – 2.

203 BUILDING AND FIRE BOARD OF APPEALS.

This amendment is the same as in the 2002, 2008, 2011, 2014, 2017 and 2020 Glendale Building and Safety Code.

This amendment establishes the creation of the joint Building and Fire Board of Appeals.

(Justification: Administrative - See justification A in the attached matrix)

Section V – 3.

1101.2 Notice and Order.

This amendment is the same as in the 2002, 2008, 2011, 2014, 2017 and 2020 Glendale Building and Safety Code.

This amendment replaces references to "substandard" and "dangerous" conditions with the term "unsafe", as determined by the building official. Additionally, this amendment makes proper reference to the Building and Fire Board of Appeals.

(Justification: Administrative - See justification A in the attached matrix)

Volume VI
Fire Standards

Section VI – 2.

Chapter 1, division II, Scope and Administration

Since this chapter is not adopted by the State Fire Marshal, this amendment is required in order to adopt the administrative provisions of the model code related to the fire prevention bureau's organization, authority, duties, permits, fees, and similar administrative subjects. This amendment adopts the chapter overall; subsequent amendments (VI-3 through VI-12) make amendments to specific sections within the chapter. This chapter is similar to the provisions of the 2020 Glendale Building and Safety Code Chapter 1. This amendment is administrative and does not affect any building standards.

(Justification: Administrative)

Section VI – 3.

103.1 Creation of agency

This amendment specifies that the authority having jurisdiction shall be the Glendale Fire Department, Fire Prevention Bureau as responsible for the implementation, administration and enforcement of the provisions of the Fire Code.

(Justification: Administrative)

Section VI – 4.

104.1.1 Environmental protection

This amendment is essentially the same as the 2020 Glendale Building and Safety Code which summarizes the existing environmental programs the Glendale Fire Department is responsible for which have effective dates ranging between 1986 and 1997. This amendment is administrative and does not affect any building standards.

(Justification: Administrative)

Section VI – 5.

105.6 Required operational permits

This amendment is administrative in nature to adjust code section numbering to be consistent with the amendment of Section VI-5 and is the same as the 2020 Glendale Building and Safety Code. This amendment is administrative and does not affect any building standards.

(Justification: Administrative)

Section VI – 6.

105.6.51 Additional operational permits

This amendment is the same as the 2020 Glendale Building and Safety Code which adds permits that are not addressed by the model code. This amendment is administrative and does not affect any building standards.

(Justification: Administrative)

Section VI – 7.

105.6 Required construction permits

This amendment is administrative in nature to adjust code section numbering to be consistent with the amendment of Section VI-8 and is the same as the 2020 Glendale Building and Safety Code. This amendment is administrative and does not affect any building standards.

(Justification: Administrative)

Section VI – 8.

Attachment 13_GBSC_2023_Analysis of Amendments

105.6.25 Additional construction permits

This amendment is the same as the 2020 Glendale Building and Safety Code which adds permits that are not addressed by the model code. This amendment is administrative and does not affect any building standards.

(Justification: Administrative)

Section VI – 9.

107.7 Fees for services

This amendment is essentially the same as the 2020 Glendale Building and Safety Code. This amendment provides the Fire Department with administrative provisions for the establishment of fees for services. Essentially, all issues associated with fees are established by Resolution of the City Council. This amendment is administrative and does not affect any building standards.

(Justification: Administrative)

Section VI – 10.

107.8 False alarms or nuisance alarms

This amendment is the same as the 2020 Glendale Building and Safety Code. This amendment authorizes a service charge for Fire Department response to false or nuisance alarms. As described in other provisions related to fees, all issues related to fees are established by Resolution of the City Council. This amendment is administrative and does not affect any building standards.

(Justification: Administrative)

Section VI – 11.

109 building and fire board of appeals

This amendment is the same as the 2020 Glendale Building and Safety Code. This amendment establishes the joint Building and Fire Board of Appeals, establishes administrative appeals procedures, and refers to the detailed provisions contained in Volume IA. This amendment is administrative and does not affect any building standards.

(Justification: Administrative)

Section VI – 12.

112.4 Violation penalties

This amendment is the same as the 2020 Glendale Building and Safety Code. It revises the provisions for penalties associated with fire code violations and refers such provisions to Volume IA and Volume VI Chapter 49, as applicable. Essentially, all issues associated with fees are established by Resolution of the City Council as well as the Glendale Municipal Code. This amendment is administrative and does not affect any building standards.

(Justification: Administrative)

Section VI – 13.

202 FALSE ALARMS

This amendment is the same as the 2020 Glendale Building and Safety Code. It provides for a more comprehensive definition of the term “false alarm”. This amendment is administrative and does not affect any building standards. It is also related to Sections VI-9.

(Justification: Administrative)

Section VI – 14.

CHAPTER 3 GENERAL REQUIREMENTS

This amendment is the same as in the 2020 Glendale Building and Safety Code. Since chapter 3 of the International Fire Code is not entirely adopted by the State Fire Marshal, this amendment is necessary in order to apply the guidelines not adopted by the State Fire Marshal. This amendment is administrative and does not affect any building standards.

(Justification: Administrative)

Section VI-15.

307.4.3 Portable outdoor fireplaces.

This amendment is the same as in the 2020 Glendale Building and Safety Code. This amendment adds restrictions related to the use of portable outdoor fireplaces when used in conjunction with one- and two-family dwellings located within a wildland-urban interface fire area. Glendale is located in a region that has a seasonally dry climate, which often experiences strong Santa Ana wind conditions. The additional restrictions require a minimum separation of 15 feet between the portable outdoor fire place and any structure, combustible material or vegetation, to address the increased fire hazards that are associated with seasonal high-wind conditions which increase the risk of open-flame devices in the wildland-urban interface fire areas. The wildland-urban interface fire areas are located in areas of the city where steep, hillside topography increase the difficulty in addressing wind-driven fire events.

(Justification: Climatic)

Section VI-16.

307.4.4 “Red-flag” and other high fire risk conditions.

This amendment is essentially the same as in the 2020 Glendale Building and Safety Code with some minor editorial updates. This amendment adds restrictions on open burning activities, including recreational fires and fires within portable outdoor fireplaces, on “red-flag” days or other days which pose a high fire risk. Glendale is located in a region that has a seasonally dry climate, which often experiences strong Santa Ana wind conditions. The additional restrictions reduce the risk of wind-driven fires that could occur on “red-flag” days that result from a combination of dry conditions and strong winds that frequently occur as a result of Glendale’s seasonal climate.

(Justification: Climatic)

Section VI-17.

308.1.5 Location near combustibles.

This amendment is the same as in the 2020 Glendale Building and Safety Code. This amendment expands restrictions on open flame sources located in wildland-urban interface fire areas and located within 10 feet of combustible construction or vegetation. Glendale is located in a region that has a seasonally dry climate, which often experiences strong Santa Ana wind conditions. The additional restrictions reduce the risk of unintentional fire ignition of combustible construction and/or vegetation, which would pose an extreme safety risk due to the dry and windy climate.

(Justification: Climatic)

Section VI-18.

308.1.9 Outdoor fires.

This amendment was part of Section VI-40 in Chapter 49 of the 2020 Glendale Building and Safety Code but is being relocated to Chapter 3. This amendment provides for restrictions on outdoor fires located in the wildland-urban interface fire areas, or High Fire Hazard Areas. Glendale is located in a region that has a seasonally dry climate, which often experiences strong Santa Ana wind conditions. The additional restrictions reduce the risk of unintentional fire ignition of combustible construction and/or vegetation, which would pose an extreme safety risk due to the dry and windy climate.

(Justification: Climatic)

Section VI – 19.

503 FIRE APPARATUS ACCESS ROADS

This amendment is the same as in the 2020 Glendale Building and Safety Code. Since Section 503 of the International Fire Code is not adopted by the State Fire Marshal, this amendment is necessary in order to apply the important provisions they contain. Geologically, the City of Glendale is exposed to a high degree of seismicity that increases the likelihood of earthquake-induced fires. Climatically, seasonal

Santa Ana wind conditions have the potential to exacerbate fire conditions, thereby requiring reliable access by fire suppression crews and equipment. Topographically, portions of Glendale are located within hillside areas that are accessible by steep, narrow and winding streets. All of these conditions contribute to the need to maintain minimum fire access standards to enable fire suppression crews to properly respond to structure and wildland fires in a manner that will prevent rapid spread throughout the community. This is related to Section VI-46.

(Justification: Administrative, Geologic, Climatic, Topographic)

Section VI – 20.

510.3 Permit required

This amendment is the same as the 2020 Glendale Building and Safety Code. This amendment facilitates emergency responder communication coverage within buildings. This amendment established administrative standards for the proper radio coverage within buildings located within the City of Glendale.

(Justification: Administrative)

Section VI – 21.

806 Natural decorative vegetation in new and existing building

This amendment facilitates the enforcement of natural cut trees used for decorative purposes. The amendment also includes the enforcement of fire-retardant treatment used for natural cut trees within the City of Glendale.

(Justification: Administrative)

Section VI – 22.

807 Decorative materials and artificial decorative vegetation in new and existing materials

This amendment facilitates the enforcement of natural and decorative vegetation materials. The amendment also includes the enforcement of fire-retardant treatment used for combustible decorative materials within the City of Glendale.

(Justification: Administrative)

Section VI – 23.

901.1.1 Aesthetics

This amendment is the same as the 2020 Glendale Building and Safety Code and is provided to ensure aesthetics of fire protection systems are taken into consideration by designers and installers, and to provide consistency with the city’s zoning code and with direction from City Council in passing the sprinkler ordinance of 1989. This amendment is administrative and does not affect any building standards.

(Justification: Administrative)

Section VI – 24.

901.6 Inspection, testing, and maintenance

This amendment is the same as the 2020 Glendale Building and Safety Code. This amendment identifies the inspection, testing, and maintenance intervals of fire protection equipment and other critical systems. This amendment also establishes professional credential requirements for those performing such services.

This amendment is administrative and does not affect any building standards. It is associated with the next amendment, VI-22.

(Justification: Administrative)

Section VI – 25.

TABLE 901.6 REQUIRED TESTING, TESTER QUALIFICATIONS, AND CERTIFICATION SUBMITTAL INTERVALS

This amendment is a continuation of the previous section, VI-21, and is essentially the same as the 2020

Glendale Building and Safety Code. The changes involve the removal electrical buss duct testing and infrared testing. This amendment also identifies the requirements of testing equipment in one convenient table format, making it much easier and faster to understand the expectations of system maintenance / testing. This amendment is administrative and does not affect any building standards.
(Justification: Administrative)

Section VI – 26.

901.11 Critical equipment

This amendment is the same as the 2020 Glendale Building and Safety Code. This amendment defines “critical equipment”, and then establishes criteria for its location, ventilation, signage, and graphics. Geologically, the City of Glendale is exposed to a high degree of seismicity that increases the likelihood of structural damage within buildings. Placement of critical equipment above the first floor of a building increases the likelihood that such equipment will be inaccessible for proper use after an earthquake. Furthermore, earthquake-induced fires are more likely to occur in regions of high seismicity, and proper ventilation of critical equipment is necessary to maintain a tenable environment where such critical equipment must be accessed during an earthquake-induced fire.
(Justification: Geologic)

Section VI – 27.

903.2.21 Where required

This amendment is the same as the 2020 Glendale Building and Safety Code reflecting Glendale’s fire sprinkler ordinance for both new and existing buildings originally adopted in 1989. Geologically, the City of Glendale is exposed to a high degree of seismicity that increases the likelihood of earthquake-induced fires. Climatically, seasonal Santa Ana wind conditions have the potential to exacerbate fire conditions, thereby placing a higher degree of reliance upon automatic fire sprinkler systems to assist in the early abatement of structure fires. Topographically, portions of Glendale are located within hillside areas that are accessible by steep, narrow and winding streets, which can delay the arrival of fire suppression resources; automatic fire sprinkler systems can provide early suppression until fire suppression resources can arrive on scene. All of these conditions contribute to the need for increased fire sprinkler standards. This amendment also includes administrative procedures for notification and enforcement.
(Justification: Administrative, Geologic, Climatic, Topographic)

Section VI – 27.

906.8 Cabinets

This amendment is the same as the 2020 Glendale Building and Safety Code. This amendment establishes administrative standards for the placement of fire extinguisher cabinets, to ensure that fire extinguishers are located in cabinets to ensure location control of fire extinguishers. The height provision contained in the amendment is intended to coordinate with disabled access provisions to ensure fire extinguishers are accessible to individuals with physical disabilities. This amendment is administrative and does not affect any building standards.
(Justification: Administrative)

Section VI – 28.

906.9.1 Extinguishers weighing 40 pounds or less

This amendment is the same as in the 2020 Glendale Building and Safety Code and is also the same as VI-26. The code has two separate provisions for fire extinguishers weighing less than or more than 40 pounds. This amendment establishes administrative standards for the placement of fire extinguisher cabinets, to ensure that fire extinguishers are located in cabinets to ensure location control of fire extinguishers. The height provision contained in the amendment is intended to coordinate with disabled access provisions to ensure fire extinguishers are accessible to individuals with physical disabilities. This amendment is administrative and does not affect any building standards.

(Justification: Administrative)

Section VI – 29.

907.6.6 Monitoring

This amendment is essentially the same as the 2020 Glendale Building and Safety Code with a revision to further ensure the reliability of fire alarm monitoring systems by requiring monitoring systems to comply with NFPA 72's provisions for central station monitoring service, a more reliable and accountable monitoring method. This amendment is administrative and does not affect any building standards.

Section VI-29 is also related to this amendment.

(Justification: Administrative)

Section VI – 30.

907.11 Certification and Identification of Certificated Systems

This amendment is essentially the same as the 2020 Glendale Building and Safety Code with revised language to clarify requirements related to alterations of existing fire alarm systems. This amendment originally appeared in the 1989 Glendale Building and Safety Code and has remained essentially the same in all editions since. This amendment establishes an administrative requirement that all new fire alarm systems, and certain existing systems, such as those that have proven to be unreliable or undergo extensive alteration, to be certificated with a nationally recognized testing laboratory and to have maintenance contract in force. This amendment is related to Section VI-28.

(Justification: Administrative)

Section VI – 31.

1032 Special egress graphics

This amendment is the same as the 2020 Glendale Building and Safety Code. This amendment establishes administrative standards for signage and graphics which may be required by the fire code official to address special circumstances.

(Justification: Administrative)

Section VI – 32.

1103.2 Emergency responder communication coverage in existing buildings

This amendment contains the provisions for adequate signal strength for emergency responder communications, which may be required by the fire code official to address special circumstances.

(Justification: Administrative)

Section VI – 33.

1103.3 Existing elevators

This amendment contains the provisions for maintenance and inspection of existing elevators which may be required by the fire code official to address special circumstances.

(Justification: Administrative)

Section VI – 34.

1104 Means of egress for existing buildings

This amendment contains provisions for required exiting of all buildings with the continue maintenance of properly functioning door hardware which may be required by the fire code official to address special circumstances.

(Justification: Administrative)

Section VI – 35.

Chapter 49 - 4901.3 Liability for damage – 4907.510 Method of Collection

The amendment is the same as the 2020 Glendale Building and Safety Code. This amendment provides the implementation, administration and enforcement provisions of Chapter 49, the chapter elated to the High Fire Hazard Area. Glendale is located in a region that has a seasonally dry climate, which often experiences strong Santa Ana wind conditions. The wildland-urban interface fire areas are located in areas of the city where steep, hillside topography increase the difficulty in addressing wind-driven fire events.

(Justification: Administrative, Climatic, Geologic, Topographic)

Section VI – 36.

5707 On-demand mobile fueling operations

This amendment contains the safety provisions for mobile fueling operations that dispense Class I, II and III liquids into the fuel tanks of motor vehicles.

(Justification: Administrative)

Section VI – 37.

Appendix B, Table B105.2, Required fire flow for buildings other than one- and two-family dwellings, group R-3 and R-4 buildings and townhouses

This amendment is the same as the 2020 Glendale Building and Safety. This amendment revises the model code’s reduction of fire flow from 75% to no more than 50% for buildings other than one- and two- family dwellings. Geologically, the City of Glendale is exposed to a high degree of seismicity that increases the likelihood of earthquake-induced damage to municipal water supply lines. Additionally, large magnitude seismic events often result in loss of power at water distribution pump stations, thereby interfering with water pressure throughout the city. The proposed amendment requires a greater fire flow requirement for buildings other than one- and two-family dwellings, thereby increasing the likelihood of adequate water supply to fight fires after a major seismic event that compromises the municipal water supply.

(Justification: Geologic)

Section VI – 38.

Appendix C, Table C102.1, Required number and spacing of fire hydrants

This amendment is the same as the 2020 Glendale Building and Safety Code which establishes fire hydrant spacing requirements, with some minor editorial clarifications. The amendment requires the average spacing between fire hydrants to be closer than permitted by the model code. Geologically, the City of Glendale is exposed to a high degree of seismicity that increases the likelihood of earthquake-induced damage to municipal water supply lines. Additionally, large magnitude seismic events often result in loss of power at water distribution pump stations, thereby interfering with water pressure throughout the city. The proposed amendment requires a closer spacing of fire hydrants, thereby resulting in better access to water to fight fires after the municipal water supply is compromised after an earthquake.

(Justification: Geologic)

Section VI – 39.

Appendix D, Fire apparatus access roads

This amendment is the same as the 2020 Glendale Building and Safety Code. Since this appendix is not adopted by the State Fire Marshal, this amendment is required in order to adopt the provisions they contain. This is related to VI-18. Geologically, the City of Glendale is exposed to a high degree of seismicity that increases the likelihood of earthquake-induced fires. Climatically, seasonal Santa Ana wind conditions have the potential to exacerbate fire conditions, thereby requiring reliable access by fire suppression crews and equipment. Topographically, portions of Glendale are located within hillside areas that are accessible by steep, narrow and winding streets. All of these conditions contribute to the need to maintain minimum fire access standards to enable fire suppression crews to properly respond to structure and wildland fires in a manner that will prevent rapid spread throughout the community.

(Justification: Administrative, Geologic, Climatic, Topographic)

Section VI – 40.

Appendix D107, one or two-family residential developments

This amendment requires new developments of one- or two-family dwellings where the number of dwelling units exceeds 30 shall be provided with two separate and approved fire apparatus access roads. This is related to VI-18. Geologically, the City of Glendale is exposed to a high degree of seismicity that increases the likelihood of earthquake-induced fires. Climatically, seasonal Santa Ana wind conditions have the potential to exacerbate fire conditions, thereby requiring reliable access by fire suppression crews and equipment. Topographically, portions of Glendale are located within hillside areas that are accessible by steep, narrow and winding streets. All of these conditions contribute to the need to maintain minimum fire access standards to enable fire suppression crews to properly respond to structure and wildland fires in a manner that will prevent rapid spread throughout the community.

(Justification: Administrative, Geologic, Climatic, Topographic)

Volume VII
Security Standards

Volume VII is hereby added to the 2023 Glendale Building and Safety Code for administrative reasons to establish Security Standards, with no changes from its previous form as it appears in the 2020 Glendale Building and Safety Code.

Volume VIII
Commercial and Industrial Property Maintenance Standards

Volume VIII is hereby added to the 2023 Glendale Building and Safety Code for administrative reasons to establish Commercial and Industrial Property Maintenance Standards, with minor changes from its previous form as it appears in the 2020 Glendale Building and Safety Code.

Volume IX
Green Building Standards

Section IX – 2.

301.1 Scope.

This amendment is the same as in the 2014, 2017 and 2020 Glendale Building and Safety Code.

This amendment clarifies the scope of the green building standards.

(Justification: Administrative and Climatic - See justification A and I in the attached Key to Justifications)

Section IX – 3.

4.106.4 Water permeable surfaces.

This amendment is the same as in the 2011, 2014, 2017 and 2020 Glendale Building and Safety Code.

This amendment reduces water runoff from exposed paved areas associated with residential development, and encourages natural percolation and on-site water retention which provides many environmental benefits.

(Justification: Climatic - See justification I in the attached Key to Justifications)

Section IX – 4.

4.509 NATURAL LIGHT AND VENTILATION.

This amendment is the same as in the 2011, 2014, 2017 and 2020 Glendale Building and Safety Code.

This amendment increases the available natural ventilation and fresh air circulation. Larger openable windows and doors also enable the occupants to rely upon artificial interior lights less, thereby saving energy each day.

(Justification: Climatic and Topographic - See justification I and J in the attached Key to Justifications)

Volume IA						
ORD SEC	Section	Title	Added to CBC	Deleted from CBC	Amended from CBC	Justification (See below for key to Justifications)
IA-2	Chapter 1 Division II, 101.2	Scope			X	A
IA-3	Chapter 1 Division II, 104.10.2	Fire code official concurrence	X			A
IA-4	Chapter 1 Division II, 104.11.5	Fire code official concurrence	X			A
IA-5	Chapter 1 Division II, 105.1	Required			X	A
IA-6	Chapter 1 Division II, 105.3	Application for permit			X	A
IA-7	Chapter 1 Division II, 105.3.1.1	Electric vehicle charging station review process			X	A, B, C & D
IA-8	Chapter 1 Division II, 105.3.2	Time limitation of application			X	A
IA-9	Chapter 1 Division II, 105.3.3	Plan review fees	X			A
IA-10	Chapter 1 Division II, 105.5	Expiration			X	A
IA-11	Chapter 1 Division II, 105.8	Responsibility of permittee	X			A
IA-12	Chapter 1 Division II, 107.3.4	Design professional in responsible charge			X	A, B & C
IA-13	Chapter 1 Division II, 109.4	Work commencing before permit issuance			X	A
IA-14	Chapter 1 Division II, 110.3.5	Lath, gypsum board and gypsum panel product inspection			X	A
IA-15	Chapter 1 Division II, 110.3.9.1	Structural observation	X			A
IA-16	Chapter 1 Division II, 110.7	Re-inspections	X			A
IA-17	Chapter 1 Division II, 113	BUILDING AND FIRE BOARD OF APPEALS			X	A
IA-18	Chapter 1 Division II, 114.1	Unlawful acts			X	A
IA-19	Chapter 1 Division II, 114.4	Violation penalties			X	A
IA-20	Chapter 1 Division II, 115.1	Authority			X	A
IA-21	Chapter 1 Division II, 115.3	Unlawful continuance			X	A
IA-22	Chapter 1 Division II, 116.6	Non-compliance	X			A
IA-23	Chapter 1 Division II, 116.7	Vacated Buildings	X			A
IA-24	Chapter 1 Division II, 118	CONSTRUCTION TOILET FACILITIES	X			A

Volume IA

ORD SEC	Section	Title	Added to CBC	Deleted from CBC	Amended from CBC	Justification (See below for key to Justifications)
IA-25	Chapter 1 Division II, 119	ON SITE CONSTRUCTION TRASH AND DEBRIS CONTROL	X			A
IA-26	Chapter 1 Division II,120	DISASTER REPAIR AND RECONSTRUCTION	X			A
IA-27	Chapter 1 Division II, 121	SANDBLASTING	X			A
IA-28	Chapter 1 Division II, 202	DEFINITIONS				A
IA-29	[F] 403.3	Combination automatic sprinkler/standpipe system			X	B, C, & D
IA-30	[F] 403.3.3	Secondary water supply			X	B, C, & D
IA-31	503.2	Construction on contiguous lots under same ownership or occupancy	X			A
IA-32	[F] 903.2.21	Where required	X			A, B, C & D
IA-33	[F] 906.8	Cabinets			X	B, C, & D
IA-34	[F] 906.9.1	Extinguishers weighing 40 pounds or less.			X	A
IA-35	[F] 907.6.6	Monitoring			X	B, C, & D
IA-36	[F] 907.9	Certification and Identification of Certificated Systems	X			A
IA-37	[F] 913.7	Fire pumps and pump rooms.	X			B, C, & D
IA-38	NOT USED					
IA-39	NOT USED					
IA-40	1505.1	General			X	C & D
IA-41	TABLE 1505.1	MINIMUM ROOF COVERING CLASSIFICATION FOR TYPES OF CONSTRUCTION			X	C & D
IA-42	1505.1.3	<i>Roof coverings within all other areas</i>			X	C & D
IA-43	1507.3.1	Deck Requirements	X			B
IA-44	TABLE 1507.3.7	CLAY AND CONCRETE TILE ATTACHMENT			X	B & C
IA-45	1511.7	Roof sheathing	X			B & D
IA-46	1613.5	Amendments to ASCE 7			X	B & D
IA-47	1613.5.1	Values for Vertical Combinations	X			B & D

Volume IA						
ORD SEC	Section	Title	Added to CBC	Deleted from CBC	Amended from CBC	Justification (See below for key to Justifications)
IA-48	1613.5.2	Wood Diaphragms	X			B & D
IA-49	1613.5.3	Structural Separation	X			B
IA-50	1613.6	Seismic design provisions for hillside buildings	X			B & D
IA-51	1613.7	Suspended ceilings	X			B
IA-52	1701.2	Technical specialties	X			B & D
IA-53	1704.2	Special inspections and tests			X	B & D
IA-54	1704.6	Structural Observation			X	A & B
IA-55	1704.6.2	Structural observation for seismic resistance			X	B
IA-56	1705.3	Concrete construction			X	B & D
IA-57	1705.13	Special inspections for seismic resistance			X	B
IA-58	1805.4.3	Drainage discharge			X	C & D
IA-59	1807.1.4	Permanent wood foundation systems		X		C
IA-60	1807.1.6	Prescriptive design of concrete and masonry foundation walls			X	B
IA-61	1807.2	Retaining walls	X			B
IA-62	1807.3.1	Limitations	X			B
IA-63	1809.3	Stepped footing			X	B
IA-64	1809.7	Prescriptive footings for light-frame construction			X	B
IA-65	TABLE 1809.7	PREScriptive FOOTINGS SUPPORTING WALLS OF LIGHT FRAME CONSTRUCTION			X	B
IA-66	1809.12	Timber footings		X		B & C
IA-67	1810.3.2.4	Timber		X		C
IA-68	1905.1	General			X	A
IA-69	1905.1.7	ACI 318 Section 14.1.4			X	B
IA-70	1905.1.9	ACI 318 Section 18.7.5	X			B
IA-71	1905.1.10	ACI 318 Section 18.10.4	X			B
IA-72	1905.1.11	ACI 318 Section 18.12.6	X			B
IA-73	2113.1	General			X	B
IA-74	2304.10.2	Fastener requirements			X	B
IA-75	2304.10.3.1	Quality of nails	X			B

Volume IA

ORD SEC	Section	Title	Added to CBC	Deleted from CBC	Amended from CBC	Justification (See below for key to Justifications)
IA-76	2304.12.2.8	Wood used in retaining walls and cribs		X		B & C
IA-77	2305.4	Hold-down connectors	X			B
IA-78	2306.2	Wood-frame diaphragms			X	B
IA-79	2306.3	Wood-frame shear walls			X	B
IA-80	2307.2	Wood-frame shear walls	X			B
IA-81	TABLE 2308.6.1	WALL BRACING REQUIREMENTS			X	B
IA-82	2308.6.5.1	Alternative braced wall (ABW)			X	B
IA-83	Figure 2308.6.5.1	ALTERNATE BRACED WALL PANEL (ABW)			X	B
IA-84	2308.6.5.2	Portal frame with hold-downs (PFH)			X	B
IA-85	Figure 2308.6.5.2	PORTAL FRAMES WITH HOLDDOWNS (PFH)			X	B
IA-86	2308.6.8.1	Foundation requirements			X	B
IA-87	2308.6.9	Attachment of sheathing			X	B
IA-88	3101.1	Scope	X			A & D
IA-89	3102.2.3	Membrane Structures Used as Shade Covers for Specific Uses	X			A & D
IA-90	3102.6.2	Membrane less than 20 feet (6096 mm)	X			A
IA-91	3109.4.4.2	Coinstruction permit; safety features required			X	D
IA-92	3109.4.4.3	Enclosure; required characteristics			X	D
IA-93	3115	Intermodal Shipping Containers	X			A & D
IA-94	3202.1.2.1	Change of use/occupancy	X			A
IA-95	3202.3.2	Windows, architectural features and mechanical equipment			X	A
IA-96	3203	PROJECTIONS INTO ALLEYS	X			A & D
IA-97	3303.8	Storm water drainage and retention during demolition	X			A
IA-98	3306.2	Walkways			X	A
IA-99	3306.9.1	Shoring	X			A
IA-100	3306.10	Protection of sidewalk excavations	X			A
IA-101	3306.11	Protection of obstructions	X			A
IA-102	3308.3	Street Use Permits	X			A
IA-103	3308.4	Mixing mortar on public property	X			A
IA-104	NOT USED					

Volume IA						
ORD SEC	Section	Title	Added to CBC	Deleted from CBC	Amended from CBC	Justification (See below for key to Justifications)
IA-105	APPENDIX I	PATIO COVERS	X			A
IA-106	Appendix I 105.1	Design Loads	X			B & D
IA-107	APPENDIX J	GRADING	X			E, F, G, H
IA-108	Appendix J101.1	Scope			X	E
IA-109	Appendix J101.3	Hazards	X			E
IA-110	Appendix J101.4	Safety precautions	X			E
IA-111	Appendix J101.5	Protection of utilities	X			E
IA-112	Appendix J101.6	Protection of adjacent property	X			E
IA-113	Appendix J101.7	Storm water control measures	X			E & G
IA-114	Appendix J101.8	Conditions of approval	X			E
IA-115	Appendix J101.9	Rules and regulations	X			E
IA-116	Appendix J102	DEFINITIONS			X	E
IA-117	Appendix J103.1	Permits required			X	E
IA-118	Appendix J103.2	Exemptions			X	E
IA-119	Appendix J103.3	Unpermitted grading	X			E
IA-120	Appendix J103.4	Grading fees	X			E
IA-121	Appendix J103.5	Bonds and insurance	X			E
IA-122	Appendix J104.2	Grading plan requirements			X	E
IA-123	Appendix J104.2.1	Grading designation	X			E, F, G & H
IA-124	Appendix J104.2.2	Regular grading requirements	X			E, F, G & H
IA-125	Appendix J104.2.3	Engineered grading requirements	X			E, F, G & H
IA-126	Appendix J104.3	Geotechnical engineering and engineering geology report			X	E, F, G & H
IA-127	Appendix J104.4	Liquefaction study			X	F & H
IA-128	Appendix J104.5	Slope failure reports	X			F, G & H
IA-129	Appendix J104.6	Permit issuance	X			E
IA-130	Appendix J105.3	Field engineer	X			E

Volume IA

ORD SEC	Section	Title	Added to CBC	Deleted from CBC	Amended from CBC	Justification (See below for key to Justifications)
IA-131	Appendix J105.4	Geotechnical engineer	X			E
IA-132	Appendix J105.5	Engineering geologist	X			E
IA-133	Appendix J105.6	Permittee	X			E
IA-134	Appendix J105.7	Building official	X			E
IA-135	Appendix J105.8	Notification of noncompliance	X			E
IA-136	Appendix J105.9	Transfer of responsibility	X			E
IA-137	Appendix J105.10	Non-inspected grading	X			E
IA-138	Appendix J105.11	Routine field inspections and reports	X			E
IA-139	Appendix J105.12	Completion of work	X			E
IA-140	Appendix J105.13	Notification of completion	X			E
IA-141	Appendix J105.14	Change of ownership	X			E
IA-142	Appendix J106.1	Maximum cut slope			X	F, G & H
IA-143	Appendix J106.2	Drainage	X			G & H
IA-144	Appendix J107.1	General			X	F, G & H
IA-145	Appendix J107.2	Surface preparation			X	F, G & H
IA-146	Appendix J107.3	Benching			X	F, G & H
IA-147	Appendix J107.6	Maximum slope			X	F, G & H
IA-148	Appendix J107.7	Slopes to receive fill	X			F, G & H
IA-149	Appendix J107.8	Inspection of fill	X			F, G & H
IA-150	Appendix J107.9	Testing of fills	X			F, G & H
IA-151	Appendix J108	SETBACKS AND RETAINING WALLS			X	F, G & H
IA-152	Appendix J109.1	General			X	F, G & H
IA-153	Appendix J109.3	Interceptor drains and overflow protection			X	F, G & H
IA-154	Appendix J109.5	Disposal	X			F, G & H
IA-155	Appendix J110.1	General			X	F, G & H
IA-156	Appendix J111	REFERENCED STANDARDS			X	E
IA-157	Appendix J112	NATIONAL POLLUTANT DISCHARGE ELIMINATION SYSTEM (NPDES) COMPLIANCE	X			F, G & H

Volume IB						
ORD SEC	Section	Title	Added to CRC	Deleted from CRC	Amended from CRC	Justification (See below for key to Justifications)
IB-2	Chapter 1 Division II, R104.10.2	Fire code official concurrence	X			A
IB-3	Chapter 1 Division II, R104.11.2	Fire code official concurrence	X			A
IB-4	Chapter 1 Division II, R105.3	Application for permit			X	A
IB-5	Chapter 1 Division II, R105.3.1.1	Determination of substantially improved or substantially damaged existing buildings in flood hazard areas			X	A
IB-6	Chapter 1 Division II, R105.3.1.2	Small residential rooftop solar energy system review process	X			A, B, C & D
IB-7	Chapter 1 Division II, R105.3.2	Time limitation of application			X	A
IB-8	Chapter 1 Division II, R105.3.3	Plan review fees	X			A
IB-9	Chapter 1 Division II, R105.5	Expiration			X	A
IB-10	Chapter 1 Division II, R105.8	Responsibility of permittee			X	A
IB-11	Chapter 1 Division II, R106.3.4	Deferred submittals	X			A
IB-12	Chapter 1 Division II, R108.6	Work commencing before permit issuance			X	A
IB-13	Chapter 1 Division II, R109.1.5.4	Structural observation	X			A
IB-14	Chapter 1 Division II, R109.1.5.5	Sound transmission control	X			A
IB-15	Chapter 1 Division II, R109.5	Reinspections	X			A
IB-16	Chapter 1 Division II, R112	BUILDING AND FIRE BOARD OF APPEALS			X	A
IB-17	Chapter 1 Division II, R113.1	Unlawful acts			X	A
IB-18	Chapter 1 Division II, R113.4	Violation penalties			X	A
IB-19	Chapter 1 Division II, R114.1	Notice to owner or owner's authorized agent			X	A
IB-20	Chapter 1 Division II, R114.2	Unlawful continuance			X	A
IB-21	Chapter 1 Division II, R115	UNSAFE STRUCTURES AND EQUIPMENT	X			A
IB-22	Chapter 1 Division II, R116	CONSTRUCTION TOILET FACILITIES	X			A
IB-23	Chapter 1 Division II, R117	ON SITE CONSTRUCTION TRASH AND DEBRIS CONTROL	X			A
IB-24	Chapter 1 Division II, R118	DISASTER REPAIR AND RECONSTRUCTION	X			A

Volume IB						
ORD SEC	Section	Title	Added to CRC	Deleted from CRC	Amended from CRC	Justification (See below for key to Justifications)
IB-25	Chapter 1 Division II, R119	SANDBLASTING	X			A
IB-26	Chapter 1 Division II, R120	PROTECTION OF PEDESTRIANS	X			A
IB-27	R301.1.3.1	<i>California licensed architect or engineer</i>			X	B & D
IB-28	R301.1.3.2	Woodframe structures			X	B
IB-29	R301.1.3.3	<i>Structures other than woodframe</i>			X	B
IB-30	R301.1.4	Seismic design provisions for buildings constructed on or into slopes steeper than one unit vertical in three units horizontal (33.3 percent slope)	X			B & D
IB-31	TABLE R301.2(1)	CLIMATIC AND GEOGRAPHIC DESIGN CRITERIA			X	A
IB-32	R301.2.2.2.5	Irregular buildings			X	B & D
IB-33	R301.2.2.3.8	Anchorage of mechanical, electrical, or plumbing components and equipment	X			B & D
IB-34	R302.1.1	Construction on contiguous lots under same ownership or occupancy	X			A
IB-35	R313	AUTOMATIC FIRE SPRINKLER SYSTEMS	X	X		B, C & D
IB-36	R314.6	Power source			X	A, B, C & D
IB-37	R319.1	Address numbers			X	A
IB-38	R401.1	Application			X	B & C
IB-39	R401.4	Soils test			X	B
IB-40	R401.5	Grading	X			E, F, G, H
IB-41	R402.1	Wood foundation		X		B & C
IB-42	R403.1.2	Continuous footing in Seismic Design Category D ₀ , D ₁ , and D ₂			X	B
IB-43	FIGURE R403.1(2)	PERMANENT WOOD FOUNDATION BASEMENT WALL SECTION		X		B & C
IB-44	FIGURE R403.1(3)	PERMANENT WOOD FOUNDATION CRAWL SPACE SECTION		X		B & C
IB-45	R403.1.3.6	Isolated concrete footings			X	B
IB-46	R403.1.5	Slope			X	B
IB-47	R404.2	Wood foundation walls		X		B & C
IB-48	R501.1	Application			X	B

Volume IB						
ORD SEC	Section	Title	Added to CRC	Deleted from CRC	Amended from CRC	Justification (See below for key to Justifications)
IB-49	R503 2.4	Openings in horizontal diaphragms	X			B
IB-50	FIGURE R503 2.4	OPENINGS IN HORIZONTAL DIAPHRAGMS	X			B
IB-51	R503 3	Particleboard		X		B
IB-52	TABLE R602 3(1)	FASTENING SCHEDULE			X	B
IB-53	R602 3 2	Top plate			X	B
IB-54	TABLE R602 3 2	SINGLE TOP PLATE SPLICE CONNECTION DETAILS			X	B
IB-55	TABLE R602 3(2)	ALTERNATE ATTACHMENTS TO TABLE R602 3(1)			X	B
IB-56	R602.10 2 3	Minimum number of braced wall panels			X	B
IB-57	TABLE R602.10 3(3)	BRACING REQUIREMENTS BASED ON SEISMIC DESIGN CATEGORY			X	B
IB-58	TABLE R602 10 4	BRACING METHODS			X	B
IB-59	TABLE R602 10 5	MINIMUM LENGTH OF BRACED WALL PANELS			X	B
IB-60	FIGURE R602 10 6.1	METHOD ABW-ALTERNATE BRACED WALL PANEL			X	B
IB-61	FIGURE R602 10 6.2	METHOD PFH- PORTAL FRAME WITH HOLD-DOWNS			X	B
IB-62	FIGURE R602 10 6.4	METHOD CS-PF-CONTINUOUSLY SHEATHED PORTAL FRAME PANEL CONSTRUCTION			X	B
IB-63	R606 4 4	Parapet walls			X	B
IB-64	R606 12 2 2 3	Reinforcement of requirements for masonry elements			X	B
IB-65	R803 2.4	Openings in horizontal diaphragms	X			B
IB-66	R902 1	Roofing covering materials			X	C & D
IB-67	R902.1 3	Roof coverings in all other areas			X	C & D
IB-68	R902 4	Roof-top-mounted photovoltaic (PV) panels systems			X	A, B & C
IB-69	R905 3 7	Application			X	A
IB-70	TABLE R905 3 7	CLAY AND CONCRETE TILE ATTACHMENT			X	A
IB-71	R907 7	Roof sheathing	X			B & D
IB-72	R918 1 7	Structural fire-resistance	X			A, B & C
IB-73	R1001 3.1	Vertical reinforcing			X	B
IB-74	APPENDIX H	PATIO COVERS	X			A
IB-75	Appendix AH105 1	Design loads			X	B & D
IB-76	Appendix Chapter A1	SEISMIC STRENGTHENING PROVISIONS FOR UNREINFORCED MASONRY BEARING WALL BUILDINGS	X			B & D

Volume IC						
ORD SEC	Section	Title	Added to CBC	Deleted from CBC	Amended from CBC	Justification (See below for key to Justifications)
IC-2	Chapter 1 Division II, 104.10.2	Fire code official concurrence	X			A
IC-3	Chapter 1 Division II, 104.11.3	Fire code official concurrence	X			A
IC-4	Chapter 1 Division II, 105.1	Permit Required			X	A
IC-5	Chapter 1 Division II, 105.3	Application for permit			X	A
IC-6	Chapter 1 Division II, 105.3.2	Time limitation of application			X	A
IC-7	Chapter 1 Division II, 105.3.3	Plan review fees	X			A
IC-8	Chapter 1 Division II, 105.5	Expiration			X	A
IC-9	Chapter 1 Division II, 105.8	Responsibility of permittee	X			A
IC-10	Chapter 1 Division II, 106.6	Design professional in responsible charge			X	A
IC-11	Chapter 1 Division II, 108.4	Work commencing before permit issuance			X	A
IC-12	Chapter 1 Division II, 109.3.5	Lath and gypsum board inspection			X	A
IC-13	Chapter 1 Division II, 110.3.8.1	Structural observation	X			A
IC-14	Chapter 1 Division II, 109.7	Reinspections	X			A
IC-15	Chapter 1 Division II, 112	BUILDING AND FIRE BOARD OF APPEALS			X	A
IC-16	Chapter 1 Division II, 113.1	Unlawful acts			X	A
IC-17	Chapter 1 Division II, 113.4	Violation penalties			X	A
IC-18	Chapter 1 Division II, 114.1	Authority			X	A
IC-19	Chapter 1 Division II, 114.3	Unlawful continuance			X	A
IC-20	Chapter 1 Division II, 115.6	Non-compliance	X			A
IC-21	Chapter 1 Division II, 115.7	Vacated Buildings	X			A
IC-22	Chapter 1 Division II, 118	CONSTRUCTION TOILET FACILITIES	X			A
IC-23	Chapter 1 Division II, 119	ON SITE CONSTRUCTION TRASH AND DEBRIS CONTROL	X			A
IC-24	Chapter 1 Division II, 120	DISASTER REPAIR AND RECONSTRUCTION	X			A

Volume IC						
ORD SEC	Section	Title	Added to CBC	Deleted from CBC	Amended from CBC	Justification (See below for key to Justifications)
IC-25	Chapter 1 Division II, 121	SANDBLASTING	X			A
IC-26	502.1	General			X	A
IC-27	503.1	General			X	A
IC-28	505.1	Replacement glass and windows			X	C & D
IC-29	1501.6.1	Walkways			X	A
IC-30	1501.6.7.1	Shoring	X			A
IC-31	1501.8	Protection of sidewalk excavations	X			A
IC-32	1501.9	Protection of obstructions	X			A
IC-33	1503.4	Street Use Permits	X			A
IC-34	1503.5	Mixing mortar on public property	X			A
IC-35	Appendix Chapter A1	SEISMIC STRENGTHENING PROVISIONS FOR UNREINFORCED MASONRY BEARING WALL BUILDINGS	X			B & D
IC-36	Appendix Chapter A3	PRESCRIPTIVE PROVISIONS FOR SEISMIC STRENGTHENING OF CRIPPLE WALLS AND SILL PLATE ANCHORAGE OF LIGHT WOOD-FRAME RESIDENTIAL BUILDINGS	X			B & D
IC-37	Appendix Chapter A4	EARTHQUAKE RISK REDUCTION IN WOOD-FRAME RESIDENTIAL BUILDINGS WITH SOFT, WEAK OR OPEN FRONT WALLS	X			B & D
IC-38	Appendix Chapter A5	REFERENCE STANDARDS	X			A

ORD SEC		Section	Title	Added to CPC	Deleted from CPC	Amended from CPC	Justification (See below for key to Justifications)
II-2		Chapter 1 Division II, 104.3.2	Plan Review Fees			X	A
II-3		Chapter 1 Division II, 104.5	Fees			X	A
II-4		Chapter 1 Division II, 105.2.6	Reinspections			X	A
II-5		Chapter 1 Division II, 107	Building and Fire Board of Appeals	X			A
II-6		815	Water Softener Using Dry Wells for Discharge	X			B

Volume II

Volume III

ORD SEC	Section	Title	Added to CMC	Deleted from CMC	Amended from CMC	Justification (See below for key to Justifications)
III-2	Chapter 1 Division II, 104.3.2	Plan Review Fees			X	A
III-3	Chapter 1 Division II, 104.5	Fees			X	A
III-4	Chapter 1 Division II, 105.2.6	Reinspections			X	A
III-5	Chapter 1 Division II, 107.0	Building and Fire Board of Appeals			X	A

Volume IV

ORD SEC	Section	Title	Added to CEC	Deleted from CEC	Amended from CEC	Justification (See below for key to Justifications)
IV-2	90.10	Materials and equipment	X			A
IV-3	90.11	Revocation of approval for use	X			A
IV-4	90.12	Building and Fire Board of Appeals	X			A
IV-5	Article 91	ENFORCEMENT	X			A
IV-6	Article 92	PERMITS AND FEES	X			A
IV-7	690.86	Solar photovoltaic panels/modules	X			A

Volume V

ORD SEC	Section	Title	Added to CBC	Deleted from CBC	Amended from CBC	Justification (See below for key to Justifications)
V-2	203	BUILDING AND FIRE BOARD OF APPEALS			X	A
V-3	1101.2	Notice and Order			X	A

Volume VI

ORD SEC	CFC / GFC Section	Title	Added to CFC	Deleted from CFC	Amended from CFC	Justification (See below for key to Justifications)
VI-2	Chapter 1, Part 2	ADMINISTRATIVE PROVISIONS	X			A
VI-3	103.1	Creation of agency	X			A
VI-4	104.1.1	Environmental protection			X	A
VI-5	105.6	Required operational permits			X	A
VI-6	105.6.51	Additional operational permits	X			A
VI-7	105.6	Required construction permits			X	A
VI-8	105.6.25	Additional construction permits	X			A
VI-9	107.7	Fee for services	X			A
VI-10	107.8	False alarms or nuisance alarms	X			A
VI-11	109	Building and fire board of appeals			X	A
VI-12	112.4	Violation penalties			X	A
VI-13	202	False alarms			X	A
VI-14	Chapter 3	Chapter 3 GENERAL REQUIREMENTS			X	C & D
VI-15	307.4.3	Portable outdoor fireplaces			X	C
VI-16	307.4.4	Red-flag and other high fire risk conditions	X			C
VI-17	308.1.5	Location near combustibles		X		C
VI-18	308.1.9	Outdoor fires	X			A, B, C, & D
VI-19	503	Fire Apparatus Access Roads	X			A
VI-20	510.3	Permit required	X			A
VI-21	806	Natural vegetation	X			A
VI-22	807	Decorative materials	X			A
VI-23	901.1.1	Aesthetics	X			B
VI-24	901.6	Inspection, testing and maintenance			X	A, B, C & D
VI-25	Table 901.6	Inspection intervals	X			B, C, & D
VI-26	901.11	Critical equipment	X			A
VI-27	903.2.21	Where required	X			A
VI-28	906.8	Cabinets			X	A
VI-29	906.9.1	Extinguisher weighing 40 pounds or less			X	A
VI-30	907.6.6	Monitoring			X	A & B
VI-31	907.11	Certification of systems	X			B
VI-32	1032	Special egress graphics	X			B

Volume VI

ORD SEC	CFC / GFC Section	Title	Added to CFC	Deleted from CFC	Amended from CFC	Justification (See below for key to Justifications)
VI-33	1103.2	ERCC in existing buildings	X			A
VI-34	1103.3	Existing elevators	X			A
VI-35	1104	Means of egress for existing buildings	X			A
VI-36	Chapter 49	Wildland urban interface			X	A, C, & D
VI-37	5707	On-demand mobile fueling	X			A, C, & D
VI-38	Appendix B Table B105	Required fire flow			X	A, C, & D
VI-39	Appendix C Table C102	Number and Distribution of Fire Hydrants			X	A, C, & D
VI-40	Appendix D	Fire Apparatus Access Roads			X	A, C, & D
VI-41	Appendix D107	One or two-family residential developments			X	A, C, & D

Volume IX

ORD SEC	Section	Title	Added to GBSC	Deleted from GBSC	Amended from GBSC	Justification (See below for key to Justifications)
IX-2	301.1	Scope			X	A & I
IX-3	4.106.4	Water permeable surfaces	X			I
IX-4	4.509	NATURAL LIGHT AND VENTILLATION	X			I & J

**KEY TO JUSTIFICATIONS FOR AMENDMENTS
TO
TITLE 24 OF THE CALIFORNIA CODE OF REGULATIONS**

- A. This amendment is necessary for administrative clarification, and does not modify a California Building Standard pursuant to California Health and Safety Code Sections 17958, 17958.5 and 17958.7. This amendment establishes administrative standards for the effective enforcement of building standards throughout the City of Glendale.
- B. This amendment is justified on the basis of a local geologic condition. The City is subject to earthquake hazards caused by its location on the Sierra Madre fault near the base of the San Gabriel Mountains. Said fault is the eastward extension of the same fault upon which the 1971 San Fernando earthquake originated. Other faults which potentially could cause seismic activity in the City include the Verdugo fault located near the southwest edge of the Verdugo Mountains and its branches to the east, the Sycamore Canyon fault, the Scholl Canyon fault and the Eagle Rock and San Rafael faults. The York Boulevard fault is also important in that it is a western extension of the Raymond Hill fault for which there is considerable evidence for recent geologic activity. Said faults are generally considered major Southern California earthquake faults which may experience rupture at any time. Thus, because the City is within a seismic area which includes earthquake faults within and through the jurisdictional limits of the City, the modifications and changes cited herein are designed to better limit property damage as a result of seismic activity and to establish criteria for repair of damaged property following a local emergency.
- C. This amendment is justified on the basis of a local climatic condition. The seasonal climatic conditions during the late summer and fall create severe fire hazards to the public health and welfare in the city. The hot, dry weather in combination with Santa Ana winds frequently results in wildland fires in the thousands of acres of brush-covered slopes in the Verdugo and San Rafael Hills, Chevy Chase Hills, and Repetto Hills area of the City. These areas extend from the City's boundary on the east to the Angeles National Forest in the north and the Verdugo Mountains at the Burbank boundary to the west. The aforementioned conditions combined with the geological characteristics of the hills within the City create hazardous conditions for which departure from the California Building Standards Code is required.
- D. Glendale topography includes significant hillsides with narrow and winding access, which makes timely response by fire suppression vehicles difficult. Additionally, long periods of dry, hot weather, combined with unpredictable seasonal winds (Santa Ana wind conditions) result in increased exposure to fire risk. The modifications and additions to the California Building Standards Code are reasonably necessary to combat the hazards brought about by local climatic conditions. Glendale has a desert weather pattern with monsoon type rain followed by long periods of hot, dry weather. The heavy rains tend to oversaturate the soil for a short time period during the year, having a detrimental effect on in-ground structures affected by varying moisture conditions. The City is situated on the alluvial flood plains of the Arroyo Verdugo Wash, Sycamore, Verdugo and Scholl Canyons and the Verdugo and San Gabriel Mountain drainages which have an

extensive history of slope failures causing serious floods and mud slides especially when a heavy rainy season occurs after a severe brush fire. New constructions or additions in said areas must be regulated to assure that hillside slides will not be exacerbated, and if possible, will be improved.

- E. This amendment is necessary for administrative clarification, which does not modify a California Building Standard pursuant to California Health and Safety Code Sections 17958, 17958.5 and 17958.7. This amendment establishes administrative standards for the effective enforcement of grading standards throughout the City of Glendale.
- F. This amendment is justified on the basis of a local geologic condition. The City of Glendale is subject to earthquake hazards caused by its location on the Sierra Madre fault near the base of the San Gabriel Mountains. Said fault is the eastward extension of the same fault upon which the 1971 San Fernando earthquake originated. Other faults which potentially could cause seismic activity in the City include the Verdugo fault located near the southwest edge of the Verdugo Mountains and its branches to the east, the Sycamore Canyon fault, the Scholl Canyon fault and the Eagle Rock and San Rafael faults. The York Boulevard fault is also important in that it is a western extension of the Raymond Hill fault for which there is considerable evidence for recent geologic activity. Said faults are generally considered major Southern California earthquake faults which may experience rupture at any time. This amendment establishes grading standards that are intended to improve the performance of graded sites that may be subjected to seismic movement, including both vertical and lateral ground surface acceleration. Thus, because the City is within a seismic area which includes earthquake faults within and through the jurisdictional limits of the City, the modifications and changes cited herein are necessary to better limit personal injury and property damage as a result of seismic activity and to establish criteria for repair of damaged property following a local emergency.
- G. This amendment is justified on the basis of a local climatic condition. The seasonal climatic conditions during the late summer and fall create severe fire hazards as hot, dry weather in combination with Santa Ana winds frequently result in wildland fires in the thousands of acres of brush-covered slopes in the Verdugo and San Rafael Hills, Chevy Chase Hills and Repetto Hills areas of the city, which can rapidly denude natural vegetation. The City of Glendale is also subjected to heavy seasonal rains, which are generally more intense than most regions in California. The City's orientation within the Verdugo Mountains results in a concentration of rainfall during the fall and winter seasons, which often result in severe ground and slope saturation. The City is situated on the alluvial flood plains of the Arroyo Verdugo Wash, Sycamore, Verdugo and Scholl Canyons and the Verdugo and San Gabriel Mountain drainages which have an extensive history of slope failures causing serious floods and mud slides especially when a heavy rainy season occurs after a severe brush fire. New construction and additions in said areas must be regulated to assure that hillside slides will not be exacerbated, and if possible, will be improved.

- H. This amendment is justified on the basis of a local topographic condition. The City of Glendale is situated in an area of significant hillside terrain, which includes areas that are very steep and prone to both surficial and deep-seated slope failures. The topography of portions of the City of Glendale include steep, continuous slopes that are several hundred feet in height, and extend across multiple parcels including privately owned property as well as public right-of-way and publicly owned open space. The topography in many areas is too steep to support significant vegetation, and is prone to erosion during seasonal heavy rains. Other portions of Glendale include lower elevation topography that is located in close proximity to natural waterways which result in high water table conditions. Such topography is typically associated with liquefaction-prone property, and many such regions have been identified on the state's Seismic Hazard Maps as candidates for potential liquefaction activity.
- I. This amendment is justified on the basis of a local climatic condition, which makes amendment of Green Building Standards reasonably necessary pursuant to Health and Safety Code (HSC) 17958.5. The seasonal hot, dry weather during the summer combined with arid conditions throughout the Los Angeles Basin region (including regional drought conditions), contribute to excessive energy demand to support cooling loads. Such conditions also contribute to a regional shortage of potable water supply. Similarly, periods of extremely cold weather during the fall and winter seasons result in significant heat loss in and around buildings.
- J. This amendment is justified on the basis of a local topographic condition, which makes amendment of Green Building Standards reasonably necessary pursuant to Health and Safety Code (HSC) 17958.5. The mountainous terrain that surrounds the Los Angeles Basin region contributes to the thermal inversion of trapped air. Such air becomes atypically warm or cold, depending on the season, thereby significantly increasing energy and water consumption. Furthermore, the thermal inversion traps all forms of air pollution, especially exhaust from hydrocarbon combustion (such as vehicle exhaust), and creates unhealthful respiratory conditions on a frequent basis.



CITY OF GLENDALE, CALIFORNIA REPORT TO THE SPECIAL CITY COUNCIL

AGENDA ITEM

Report: Introduction and Adoption of Ordinance Amending 2023 Glendale Building and Safety Code and Adoption of Amended Findings

1. Ordinance for Introduction Amending City of Glendale Ordinance 5998 which established the 2023 Glendale State Building Code relating to:
 - a. Section IA-38, Table 1004.1.2 Maximum Floor Area Allowances per occupant
 - b. Section IA-39, Table 1006.2.1 Spaces With One Exit or Exit Access Doorway
 - c. Section IA-104, Appendix F Rodent Proofing
 - d. Section IA-73, Section 2113.1 General
2. Resolution Adopting Findings and Analysis of Amendments to the California Building Standards Code [Title 24, California Code of Regulations]

COUNCIL ACTION

Item Type: Action Item

Approved for April 30, 2024 **calendar**

EXECUTIVE SUMMARY

Every three years the State of California adopts new model codes to establish uniform building standards for construction and maintenance of buildings, plumbing systems, mechanical systems, electrical systems, and fire and life safety systems. Pursuant to Health and Safety Code Section local jurisdictions are mandated to adopt such codes along with any amendments desired by the local jurisdiction after which the adopted amendments are submitted to the California Building Standards Commission (CBSC).

On November 15, 2022, the City Council adopted Ordinance No. 5998 which established the 2023 Glendale Building and Safety Code. A subsequent letter dated March 5, 2024, from the CBSC informed the City that we should not be enforcing these amendments unless they are justified based upon the local geologic, topographic, or climatic conditions, and requiring the City to readopt findings or remove these local amendments (see Exhibit 2). The Community Development Department is requesting to amend Ordinance No. 5998 by removing and/or altering four amendments subject to justification of local climatic, geological, and/or topographical conditions.

RECOMMENDATION

Adopt the Resolution Adopting Findings and introduce and adopt an ordinance amending four (4) amendments contained in Ordinance 5998 which adopted the 2022 Building and Safety Code.

ANALYSIS

Every three years, the State of California adopts new model codes to establish uniform standards for the construction and maintenance of buildings, plumbing systems, mechanical systems, electrical systems, and fire and life safety systems. Pursuant to Health and Safety Code Section 18941.5, local jurisdictions are mandated to adopt such state codes, generally within 180 days after publication of the code by the California Building Standards Commission. Prior to adoption, amendments to the state codes desired by the local jurisdiction may be made if each amendment can be justified on the basis of a local climatic, geological, and/or topographical condition which affects the jurisdiction.

On November 15, 2022, pursuant to Health and Safety Code 18941.5, the City of Glendale adopted Resolution 22-162, which adopted legislative findings supporting the amendments and changes to the California State Building Code as contained in Ordinance 5998 which established the 2023 Glendale Building and Safety Code. Four of the amendments contained in the ordinance Section IA-38, Table 1004.1.2 Maximum Floor Area Allowances per occupant; Section IA-39, Table 1006.2.1 Spaces With One Exit or Exit Access Doorway, Section IA-73, Section 2113.1 General and Section IA-104 and Appendix F Rodent Proofing were adopted with a justification that these were an administrative action since the amendments were developed to match the City's Zoning Code. These justifications were the same justifications that were accepted by the California Building Standards Commission ("CBSC") in the 2019 process adopting the 2020 Glendale Building and Safety Code.

Upon review of the City's latest ordinance, the CBSC has determined that they are no longer accepting an administrative justification of these code changes and in a letter dated March 5, 2024, has informed the City that we should not be enforcing these amendments (**Exhibit 2**) unless they are justified based upon the local geologic, topographic, or climatic conditions.

The code amendments areas affected are with respect to the following:

1. Section IA-38, TABLE 1004.1.2 MAXIMUM FLOOR AREA ALLOWANCES PER OCCUPANT - This amendment defines an occupant load factor for billiard/pool tables and garment manufacturing; and
2. Section IA-39, TABLE 1006.2.1 SPACES WITH ONE EXIT OR EXIT ACCESS DOORWAY - This amendment defines a second exit threshold for garment manufacturing; and

3. Section IA – 104. Appendix F RODENT PROOFING. This amendment establishes protection to building and structures from rodents.
4. Section IA – 73., 2113.1 General. This amendment defines the requirements for a partial repair of an existing masonry chimney.

The Community Development Department has reviewed the impacts of enforcing the State code language as opposed to the City’s amended language and concluded that this would not affect the City’s ability to enforce Zoning Code or DRB regulations for amendments (1) Section IA-38, TABLE 1004.1.2 MAXIMUM FLOOR AREA ALLOWANCES PER OCCUPANT , (2) Section IA-39, TABLE 1006.2.1 SPACES WITH ONE EXIT OR EXIT ACCESS DOORWAY and (3) 1. Section IA – 104. Appendix F RODENT PROOFING. As such, staff recommends removing **all three** local amendments and instead adopting the State code language.

Additionally, staff has reevaluated amendment (4) Section IA – 73., 2113.1 General, and concluded that a local geotechnical justification is appropriate. The new justification, in lieu of an administrative justification, will satisfy CBSC’s concerns. Staff’s recommendation is to modify the amendment by removal of the administrative justification and application of a geotechnical justification for Section IA – 73., 2113.1 General.

The strikethrough language of the affected amendments can be found in Exhibit 1 under their respective section (page 40, 42, 104, and 345).

STAKEHOLDERS/OUTREACH

Not applicable.

FISCAL IMPACT

There is no fiscal impact

ENVIRONMENTAL REVIEW (CEQA/NEPA)

The adoption of the Resolution and Ordinance is exempt from further review under the California Environmental Quality Act (CEQA) in that it is not a project which has the potential for causing a significant effect on the environment under Title 14 of the California Code of Regulations Section 15061(b)(3).

CAMPAIGN DISCLOSURE

This item is exempt from campaign disclosure requirements.

ALTERNATIVES TO STAFF RECOMMENDATION

Alternative 1. Decline adoption of ordinance amending the 2022 Glendale Building

Code amendments and retain current amendments resulting in the City not being in compliance with the CBSC; or

Alternative 3. Consider another alternative not proposed by staff.

ADMINISTRATIVE ACTION

Submitted by:

Bradley Calvert, Director of Community Development
Ara Sargsyan, Building Official

Prepared by:

Ara Sargsyan, Building Official

Approved by:

Roubik R. Golanian, P.E., City Manager

EXHIBITS/ATTACHMENTS

Exhibit 1: Analysis of Amendments to the California Code of Regulations

Exhibit 2: Letter from California Building Standards Commission dated March 5, 2024

BUILDING STANDARDS COMMISSION

2525 Natomas Park Drive, Suite 130
Sacramento, California 95833-2936
(916) 263-0916

March 5, 2024

City of Glendale
Community Development
Ara Sargsyan, Building Official
633 E Broadway Room 101
Glendale, CA 91206
ASargsyan@Glendaleca.gov

Re: Ordinance # 5998 - Partial

Dear Mr. Sargsyan:

The purpose of this letter is to provide the determination of the California Building Standards Commission (CBSC) following review of the ordinance referenced above with express findings received from City of Glendale on 12/15/22.

Our review finds the submittal to contain one ordinance modifying provisions of the 2022 California Building Standards Code, Title 24, California Code of Regulations (Title 24), including express findings and expressly marked modifications in compliance with Health and Safety Code (HSC) Sections 17958.7 and 18941.5. The code modifications are accepted for filing with the **exception of Part 2 2022 California Building Code, Section IA-38, Table 1004.1.2, IA-39 Table 1006.2.1, IA-73 Section 2113.1, IA-104 Appendix F and Part 10 California Existing Building Code Appendices A4 and A6**. Please review and provide findings for the aforementioned code sections to obtain a complete filing. This letter attests only to the satisfaction of the cited law for filing of expressly marked local code amendments supported by express findings with CBSC. CBSC is not authorized by law to evaluate the merit of the findings.

Local modifications to the code are specific to each edition of the code. Local modifications must be readopted and filed with CBSC for each subsequent triennial edition of the code to remain in effect.

Additional information: Fire Protection District ordinances making modifications to Title 24, HSC Section 13869.7 requires such ratified ordinances and express findings to be filed with the Department of Housing and Community Development, Division of Codes and Standards, State Housing Law Program, rather than CBSC. Ordinances making modifications to the energy efficiency and conservation provisions in the California Energy Code, Part 6 of Title 24, may require approval from the California Energy Commission pursuant to Public Resources Code Section 25402.1(h)(2).

If you have questions or need further information, you may contact me at (916) 263-0916.

Sincerely,

Beth Maynard

Beth Maynard
Associate Construction Analyst



CITY OF GLENDALE, CALIFORNIA REPORT TO THE SPECIAL CITY COUNCIL

AGENDA ITEM

Report: Introduction and Adoption of Ordinance Amending 2023 Glendale Building and Safety Code and Adoption of Amended Findings

1. Ordinance for Introduction Amending City of Glendale Ordinance 5998 which established the 2023 Glendale State Building Code relating to:
 - a. Section IA-38, Table 1004.1.2 Maximum Floor Area Allowances per occupant
 - b. Section IA-39, Table 1006.2.1 Spaces With One Exit or Exit Access Doorway
 - c. Section IA-104, Appendix F Rodent Proofing
 - d. Section IA-73, Section 2113.1 General
2. Resolution Adopting Findings and Analysis of Amendments to the California Building Standards Code [Title 24, California Code of Regulations]

COUNCIL ACTION

Item Type: Action Item

Approved for April 30, 2024 **calendar**

EXECUTIVE SUMMARY

Every three years the State of California adopts new model codes to establish uniform building standards for construction and maintenance of buildings, plumbing systems, mechanical systems, electrical systems, and fire and life safety systems. Pursuant to Health and Safety Code Section local jurisdictions are mandated to adopt such codes along with any amendments desired by the local jurisdiction after which the adopted amendments are submitted to the California Building Standards Commission (CBSC).

On November 15, 2022, the City Council adopted Ordinance No. 5998 which established the 2023 Glendale Building and Safety Code. A subsequent letter dated March 5, 2024, from the CBSC informed the City that we should not be enforcing these amendments unless they are justified based upon the local geologic, topographic, or climatic conditions, and requiring the City to readopt findings or remove these local amendments (see Exhibit 2). The Community Development Department is requesting to amend Ordinance No. 5998 by removing and/or altering four amendments subject to justification of local climatic, geological, and/or topographical conditions.

{{section.number}}>{{item.number}}

RECOMMENDATION

Adopt the Resolution Adopting Findings and introduce and adopt an ordinance amending four (4) amendments contained in Ordinance 5998 which adopted the 2022 Building and Safety Code.

ANALYSIS

Every three years, the State of California adopts new model codes to establish uniform standards for the construction and maintenance of buildings, plumbing systems, mechanical systems, electrical systems, and fire and life safety systems. Pursuant to Health and Safety Code Section 18941.5, local jurisdictions are mandated to adopt such state codes, generally within 180 days after publication of the code by the California Building Standards Commission. Prior to adoption, amendments to the state codes desired by the local jurisdiction may be made if each amendment can be justified on the basis of a local climatic, geological, and/or topographical condition which affects the jurisdiction.

On November 15, 2022, pursuant to Health and Safety Code 18941.5, the City of Glendale adopted Resolution 22-162, which adopted legislative findings supporting the amendments and changes to the California State Building Code as contained in Ordinance 5998 which established the 2023 Glendale Building and Safety Code. Four of the amendments contained in the ordinance Section IA-38, Table 1004.1.2 Maximum Floor Area Allowances per occupant; Section IA-39, Table 1006.2.1 Spaces With One Exit or Exit Access Doorway, Section IA-73, Section 2113.1 General and Section IA-104 and Appendix F Rodent Proofing were adopted with a justification that these were an administrative action since the amendments were developed to match the City's Zoning Code. These justifications were the same justifications that were accepted by the California Building Standards Commission ("CBSC") in the 2019 process adopting the 2020 Glendale Building and Safety Code.

Upon review of the City's latest ordinance, the CBSC has determined that they are no longer accepting an administrative justification of these code changes and in a letter dated March 5, 2024, has informed the City that we should not be enforcing these amendments (**Exhibit 2**) unless they are justified based upon the local geologic, topographic, or climatic conditions.

The code amendments areas affected are with respect to the following:

1. Section IA-38, TABLE 1004.1.2 MAXIMUM FLOOR AREA ALLOWANCES PER OCCUPANT - This amendment defines an occupant load factor for billiard/pool tables and garment manufacturing; and
2. Section IA-39, TABLE 1006.2.1 SPACES WITH ONE EXIT OR EXIT ACCESS DOORWAY - This amendment defines a second exit threshold for garment manufacturing; and

3. Section IA – 104. Appendix F RODENT PROOFING. This amendment establishes protection to building and structures from rodents.
4. Section IA – 73., 2113.1 General. This amendment defines the requirements for a partial repair of an existing masonry chimney.

The Community Development Department has reviewed the impacts of enforcing the State code language as opposed to the City’s amended language and concluded that this would not affect the City’s ability to enforce Zoning Code or DRB regulations for amendments (1) Section IA-38, TABLE 1004.1.2 MAXIMUM FLOOR AREA ALLOWANCES PER OCCUPANT , (2) Section IA-39, TABLE 1006.2.1 SPACES WITH ONE EXIT OR EXIT ACCESS DOORWAY and (3) 1. Section IA – 104. Appendix F RODENT PROOFING. As such, staff recommends removing **all three** local amendments and instead adopting the State code language.

Additionally, staff has reevaluated amendment (4) Section IA – 73., 2113.1 General, and concluded that a local geotechnical justification is appropriate. The new justification, in lieu of an administrative justification, will satisfy CBSC’s concerns. Staff’s recommendation is to modify the amendment by removal of the administrative justification and application of a geotechnical justification for Section IA – 73., 2113.1 General.

The strikethrough language of the affected amendments can be found in Exhibit 1 under their respective section (page 40, 42, 104, and 345).

STAKEHOLDERS/OUTREACH

Not applicable.

FISCAL IMPACT

There is no fiscal impact

ENVIRONMENTAL REVIEW (CEQA/NEPA)

The adoption of the Resolution and Ordinance is exempt from further review under the California Environmental Quality Act (CEQA) in that it is not a project which has the potential for causing a significant effect on the environment under Title 14 of the California Code of Regulations Section 15061(b)(3).

CAMPAIGN DISCLOSURE

This item is exempt from campaign disclosure requirements.

ALTERNATIVES TO STAFF RECOMMENDATION

Alternative 1. Decline adoption of ordinance amending the 2022 Glendale Building

Code amendments and retain current amendments resulting in the City not being in compliance with the CBSC; or

Alternative 3. Consider another alternative not proposed by staff.

ADMINISTRATIVE ACTION

Submitted by:

Bradley Calvert, Director of Community Development
Ara Sargsyan, Building Official

Prepared by:

Ara Sargsyan, Building Official

Approved by:

Roubik R. Golanian, P.E., City Manager

EXHIBITS/ATTACHMENTS

Exhibit 1: Analysis of Amendments to the California Code of Regulations

Exhibit 2: Letter from California Building Standards Commission dated March 5, 2024